

Owner's Manual

Operation & Care

INSTALLER: Leave this manual with party responsible for use and operation.

OWNER: Retain this manual for future reference.

Contact your dealer with questions on installation, operation, or service.

NOTICE: DO NOT DISCARD THIS MANUAL

QUADRA-FIRE®

DISCOVERY II WOOD APPLIANCE

Automatic Combustion Control (ACC)

Model: *DISCOVERY-II*

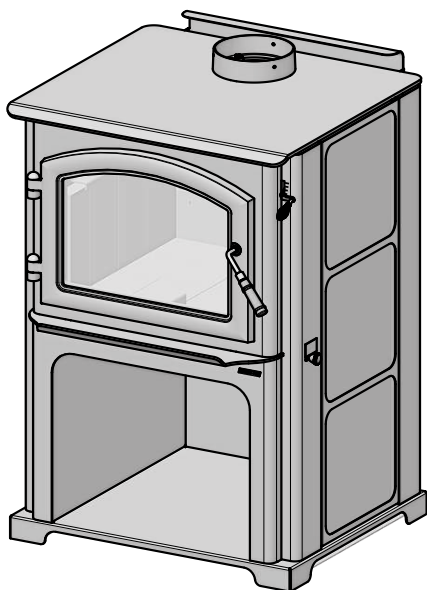

Tested and
Listed by  Portland
Oregon USA
C US
OMNI-Test Laboratories, Inc.

WARNING



Fire Risk.

For use with solid wood fuel only.
Other fuels may overfire and generate
poisonous gases (i.e. carbon monoxide).

WARNING



If the information in these instructions is not followed exactly, a fire could result causing property damage, personal injury, or death.

- Do not store or use gasoline or other flammable vapors and liquids in the vicinity of this or any other appliance.
- Do not overfire - If appliance or chimney connector glows, you are overfiring. Overfiring will void your warranty.
- Comply with all minimum clearances to combustibles as specified. Failure to comply may cause house fire.

WARNING



HOT SURFACES!

Glass and other surfaces are hot during operation AND cool down.

Hot glass will cause burns.

- Do not touch glass until it is cooled
- NEVER allow children to touch glass
- Keep children away
- CAREFULLY SUPERVISE children in same room as appliance.
- Alert children and adults to hazards of high temperatures
- **High temperatures may ignite clothing or other flammable materials.**
- Keep clothing, furniture, draperies and other flammable materials away.

NOTE

To obtain a French translation of this manual, please contact your dealer or visit www.quadrafire.com

Pour obtenir une traduction française de ce manuel, s'il vous plaît contacter votre revendeur ou visitez www.quadrafire.com

myhht
FACTORY
training

Installation and service of this appliance should be performed by qualified personnel. Hearth & Home Technologies recommends HHT Factory Trained or NFI certified professionals.



NOTE: Clearances may only be reduced by means approved by the regulatory authority having jurisdiction

A. Sample of Serial Number / Safety Label

LOCATION: Back of appliance



CAUTION: HOT WHILE IN OPERATION DO NOT TOUCH, KEEP CHILDREN AND CLOTHING AWAY. CONTACT MAY CAUSE SKIN BURNS. KEEP FURNISHINGS AND OTHER COMBUSTIBLE MATERIAL FAR AWAY FROM THE APPLIANCE. SEE NAMEPLATE AND INSTRUCTIONS.
ATTENTION: BRULURES A LA PEAU. GARDEZ LES MEUBLES ET LES MATERIAUX COMBUSTIBLES LOIN DE L'ESPACE DESIGNÉ DE L'INSTALLATION. LE CONTACT PEUT CAUSER DES BRULURES A LA PEAU. GARDEZ LES MEUBLES ET LES MATERIAUX COMBUSTIBLES LOIN DE L'ESPACE DESIGNÉ DE L'APPAREIL. VOIR L'ÉTIQUETTE ET LES INSTRUCTIONS.

LISTED ROOM HEATER, SOLID FUEL TYPE: ALSO FOR USE IN MOBILE HOMES (UW) 04 HUD. "For Use with Solid Wood Fuel Only"

APPAREIL DE CHAUFFAGE DE PIÈCE DE TYPE DE COMBUSTIBLE SOLIDE. POUR USAGE DANS LES MAISONS MOBILES (UW) 04 HUD. "Pour Usage Avec Bois Solide Seulement"

QUADRA-FIRE 3100 ACC Series TESTED TO/TESTÉ A: UL 1483-11, U.L.C. 2827-00

SERIAL NO. / NUMÉRO DE SÉRIE 007196

PREVENT HOUSE FIRES / PRÉVENTION DES FEUX DE MAISON
Install and use only in accordance with manufacturer's installation and operating instructions. Contact local building or fire officials about restrictions and installation inspections in your area. Do not obstruct the space beneath heater.
WARNING - For Mobile Homes: Do not install in a sleeping room. An outside combustion air inlet must be provided and unrestricted while unit is in use. The structural integrity of the mobile home, floor, ceiling and walls must be maintained. The stove needs to be properly grounded to the frame of the mobile home. Components required for mobile home installation: Outside Air Kit, Part Number QAK-ACC. Refer to manufacturer's instructions and local codes for precautions required for passing chimney through a combustible wall or ceiling and maximum offsets. Inspect and clean chimney frequently - Under Certain Conditions of Use, Creosote Buildup May Occur Rapidly. Do not connect this unit to a chimney serving another appliance. Optional Blower, Part BK-ACC. Electrical Rating: 115 VAC, 1.2 Amps, 60 Hz. Route power cord away from unit. Do not route cord under or in front of appliance. DANGER: Risk of electrical shock. Disconnect power supply before servicing. Replace glass only with 5mm ceramic available from your dealer. Do not use grate or elevate fire. Build wood fire directly on hearth. Do not overfire - If heater or chimney connector glows, you are overfiring. Operate only with the fuel loading door closed. Open only to add fuel to the fire.

INSTALLER'S SPECIFICATIONS:
SINGLE WALL: Six inch (6 inches) (152mm) diameter, listed double wall air insulated connector pipe with listed factory-built UL 1035HT* Class "A" chimney, and the referenced clearances.
DOUBLE WALL: Six inch (6 inches) (152mm) diameter, listed double wall air insulated connector pipe with listed factory-built UL 1035HT* Class "A" chimney, or a listed double wall pipe by Dura-Vent DVL, Serkik, Metalbestos DS or Security CL double wall connector pipe. Must be equipped with a spark arrester.
MOBILE HOME: Dimensions below when installing unit.
APPLY DOUBLE WALL CLEARANCES TO COMBUSTIBLE MATERIALS: In inches & (millimeters)
NOTE: All "A", "C" and "F" Dimensions are to inside diameter of the flue.

Table with columns A, B, C, D, E, F, G, H and rows for SINGLE WALL PIPE, DOUBLE WALL PIPE, and DOUBLE WALL PIPE. Includes installation instructions for vertical and horizontal placement.

SPECIFICATIONS DE LA VENTILATION:
MUR SIMPLE: Six (6) inches (152mm) de diamètre le connecteur de conduit de mur ou bloc de minimum de 24MSDS, avec une cheminée 5605 en le Classe "A", adéquate pour usage avec les combustibles solides, avec espaces libres réduits.
MUR DOUBLE: Six (6) inches (152mm) de diamètre, le connecteur de conduit double avec une cheminée 5605 en classe UL 1035HT* de Classe "A", ou une cheminée 5605 en classe UL 1035HT* de Classe "A", ou une cheminée 5605 en classe UL 1035HT* de Classe "A", ou une cheminée 5605 en classe UL 1035HT* de Classe "A".
MOBILE HOME: Utilisez un conduit de mur double par Dura-Vent DVL, Serkik ou Security CL. Ceci être équipé d'un arrêt d'éclaboussure. Utilisez les dimensions ci-dessous pour l'installation de l'unité.
APPLIQUER LES ESPACES LIBRES POUR LES MURS DOUBLE À DES MATÉRIELS COMBUSTIBLES DU POSEAU & (millimètres)
* Les dimensions "A", "C", "E" & "F" sont prises du diamètre intérieur du conduit.

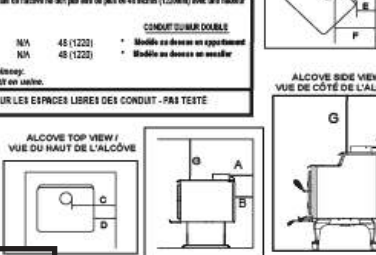
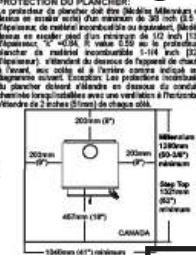
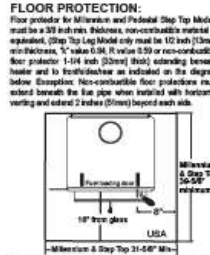

Manufactured by: FARTH HOME. 1445 N. Highway, Colton, WA 99114

Made in U.S.A. and Imported parts. Fabrique aux États-Unis et des pièces importées.

2015 2016 2017 Jan. Feb. Mar. Apr. May June July Aug. Sept. Oct. Nov. Dec.

U.S. ENVIRONMENTAL PROTECTION AGENCY Certified to comply with 2015 particulate emission standards at 1.1 GHR EPA Method 29 and 50. This wood heater meets the requirements of 40 CFR 60.403.

Safety Alert Key:

- **DANGER!** Indicates a hazardous situation which, if not avoided will result in death or serious injury.
- **WARNING!** Indicates a hazardous situation which, if not avoided could result in death or serious injury.
- **CAUTION!** Indicates a hazardous situation which, if not avoided, could result in minor or moderate injury.
- **NOTICE:** Indicates practices which may cause damage to the appliance or to property.

TABLE OF CONTENTS

A. Sample of Serial Number / Safety Label	2	3 Maintenance and Service.....15	
B. Warranty Policy.....	4	A. Quick Reference Maintenance Guide.....	15
C. Quick Start Guide	6	B. General Maintenance	16
1 Listing and Code Approvals	7	4 Troubleshooting Guide.....17	
A. Appliance Certification	7	5 Service Part Replacement.....18	
B. BTU & Efficiency Specifications.....	7	A. Glass Replacement	18
C. Mobile Home Approved	7	B. Firebrick Replacement	18
D. Glass Specifications	7	C. Snap Disc Replacement.....	18
2 Operating Instructions	8	D. Door Handle Assembly	19
A. Over-Firing Your Appliance.....	8	E. Baffle Removal	19
B. Wood Selection & Storage.....	8	F. Decorative Panel Removal & Installation	20
C. Burning Process	8	G. Tube Channel Assembly Replacement	21
D. Air Controls.....	9	6 Reference Materials	22
E. Using Burn Rate Air Control & ACC System	9	A. Service & Maintenance Log.....	22
F. Burn Rates and Operating Efficiency	10	B. Service Parts & Accessories.....	23
G. Building A Fire	11		
H. Correct Baffle & Blanket Placement	12		
I. Blower Operating Instructions	13		
J. Opacity (Smoke)	13		
K. Clear Space.....	13		
L. Negative Pressure.....	14		
M. Frequently Asked Questions	14		

B. Warranty Policy

Hearth & Home Technologies, on behalf of its hearth brands (“HHT”), extends the following warranty for HHT gas, wood, pellet, coal and electric hearth appliances that are purchased from an HHT authorized dealer.

WARRANTY COVERAGE:

HHT warrants to the original owner of the HHT appliance at the site of installation, and to any transferee taking ownership of the appliance at the site of installation within two years following the date of original purchase, that the HHT appliance will be free from defects in materials and workmanship at the time of manufacture. After installation, if covered components manufactured by HHT are found to be defective in materials or workmanship during the applicable warranty period, HHT will, at its option, repair or replace the covered components. HHT, at its own discretion, may fully discharge all of its obligations under such warranties by replacing the product itself or refunding the verified purchase price of the product itself. The maximum amount recoverable under this warranty is limited to the purchase price of the product. This warranty is subject to conditions, exclusions and limitations as described below.

WARRANTY PERIOD:

Warranty coverage begins on the date of original purchase. In the case of new home construction, warranty coverage begins on the date of first occupancy of the dwelling or six months after the sale of the product by an independent, authorized HHT dealer/ distributor, whichever occurs earlier. The warranty shall commence no later than 24 months following the date of product shipment from HHT, regardless of the installation or occupancy date. The warranty period for parts and labor for covered components is produced in the following table.

The term “Limited Lifetime” in the table below is defined as: 20 years from the beginning date of warranty coverage for gas appliances, and 10 years from the beginning date of warranty coverage for wood, pellet, and coal appliances. These time periods reflect the minimum expected useful lives of the designated components under normal operating conditions.

Warranty Period		HHT Manufactured Appliances and Venting							Components Covered
Parts	Labor	Gas	Wood	Pellet	EPA Wood	Coal	Electric	Venting	
1 Year		X	X	X	X	X	X	X	All parts and material except as covered by Conditions, Exclusions, and Limitations listed
2 years				X	X	X			Igniters, electronic components, and glass
		X	X	X	X	X			Factory-installed blowers
			X						Molded refractory panels
		X							Ignition Modules
3 years				X					Firepots and burnpots
5 years	1 year			X	X				Castings and baffles
7 years	3 years		X	X	X				Manifold tubes, HHT chimney and termination
10 years	1 year	X							Burners, logs and refractory
Limited Lifetime	3 years	X	X	X	X	X			Firebox and heat exchanger
90 Days		X	X	X	X	X	X	X	All replacement parts beyond warranty period

See conditions, exclusions, and limitations on next page.

WARRANTY CONDITIONS:

- This warranty only covers HHT appliances that are purchased through an HHT authorized dealer or distributor. A list of HHT authorized dealers is available on the HHT branded websites.
- This warranty is only valid while the HHT appliance remains at the site of original installation.
- This warranty is only valid in the country in which the HHT authorized dealer or distributor that sold the appliance resides.
- Contact your installing dealer for warranty service. If the installing dealer is unable to provide necessary parts, contact the nearest HHT authorized dealer or supplier. Additional service fees may apply if you are seeking warranty service from a dealer other than the dealer from whom you originally purchased the product.
- Check with your dealer in advance for any costs to you when arranging a warranty call. Travel and shipping charges for parts are not covered by this warranty.

WARRANTY EXCLUSIONS:

This warranty does not cover the following:

- Changes in surface finishes as a result of normal use. As a heating appliance, some changes in color of interior and exterior surface finishes may occur. This is not a flaw and is not covered under warranty.
- Damage to printed, plated, or enameled surfaces caused by fingerprints, accidents, misuse, scratches, melted items, or other external sources and residues left on the plated surfaces from the use of abrasive cleaners or polishes.
- Repair or replacement of parts that are subject to normal wear and tear during the warranty period. These parts include: paint, wood, pellet and coal gaskets, firebricks, grates, flame guides, batteries and the discoloration of glass.
- Expansion, contraction, or movement of certain parts causing noise. These conditions are normal and complaints related to this noise are not covered by this warranty.
- Damages resulting from: (1) failure to install, operate, or maintain the appliance in accordance with the installation instructions, operating instructions, and listing agent identification label furnished with the appliance; (2) failure to install the appliance in accordance with local building codes; (3) shipping or improper handling; (4) improper operation, abuse, misuse, continued operation with damaged, corroded or failed components, accident, or improperly/incorrectly performed repairs; (5) environmental conditions, inadequate ventilation, negative pressure, or drafting caused by tightly sealed constructions, insufficient make-up air supply, or handling devices such as exhaust fans or forced air furnaces or other such causes; (6) use of fuels other than those specified in the operating instructions; (7) installation or use of components not supplied with the appliance or any other components not expressly authorized and approved by HHT; (8) modification of the appliance not expressly authorized and approved by HHT in writing; and/or (9) interruptions or fluctuations of electrical power supply to the appliance.
- Non-HHT venting components, hearth components or other accessories used in conjunction with the appliance.
- Any part of a pre-existing fireplace system in which an insert or a decorative gas appliance is installed.
- HHT's obligation under this warranty does not extend to the appliance's capability to heat the desired space. Information is provided to assist the consumer and the dealer in selecting the proper appliance for the application. Consideration must be given to appliance location and configuration, environmental conditions, insulation and air tightness of the structure.

This warranty is void if:

- The appliance has been over-fired or operated in atmospheres contaminated by chlorine, fluorine, or other damaging chemicals. Over-firing can be identified by, but not limited to, warped plates or tubes, rust colored cast iron, bubbling, cracking and discoloration of steel or enamel finishes.
- The appliance is subjected to prolonged periods of dampness or condensation.
- There is any damage to the appliance or other components due to water or weather damage which is the result of, but not limited to, improper chimney or venting installation.

LIMITATIONS OF LIABILITY:

- The owner's exclusive remedy and HHT's sole obligation under this warranty, under any other warranty, express or implied, or in contract, tort or otherwise, shall be limited to replacement, repair, or refund, as specified above. In no event will HHT be liable for any incidental or consequential damages caused by defects in the appliance. Some states do not allow exclusions or limitation of incidental or consequential damages, so these limitations may not apply to you. This warranty gives you specific rights; you may also have other rights, which vary from state to state. EXCEPT TO THE EXTENT PROVIDED BY LAW, HHT MAKES NO EXPRESS WARRANTIES OTHER THAN THE WARRANTY SPECIFIED HEREIN. THE DURATION OF ANY IMPLIED WARRANTY IS LIMITED TO DURATION OF THE EXPRESSED WARRANTY SPECIFIED ABOVE.

C. Quick Start Guide

Note: These are generic drawings and may not represent your specific model.

ITEMS NEEDED FOR FIRST FIRE: 10 Pieces of Newspaper, 10-20 Pieces of Dry Kindling and a Few Pieces of Dry Split Wood.

OPEN AIR CONTROLS

HIGH
BURN RATE CONTROL (Upper Right Corner)

HIGH
AUTOMATIC COMBUSTION CONTROL (ACC) (Middle right hand side)

1

LOAD WOOD

2

ADD NEWSPAPER

3

ADD KINDLING

LIGHT THE PAPER

4

WARNING! Risk of Fire

Close and securely latch the door after the fire has started, and after refueling, to prevent:

- Spillage of smoke, flame and carbon monoxide
- Spillage of sparks, coals and logs
- Over-firing

DO NOT leave the appliance unattended with the door open.

Starting a fire may not require an open door for draft. The air control should supply adequate draft.

5

ADD MORE WOOD

6

REDUCE AIR CONTROL

Set to desired heat output

LOW
BURN RATE CONTROL (Upper Right Corner)

LOW
AUTOMATIC COMBUSTION CONTROL (ACC) (Middle right hand side)

7

The appliance is ready for normal operation.

1 Listing and Code Approvals

A. Appliance Certification

Model:	Discovery II Wood Appliance
Laboratory:	OMNI Test Laboratories, Inc.
Report No & Date:	061-S-66-6
Type:	Listed Room Appliance, Solid Fuel Type
Standard:	UL 1482-96 and ULC S627-00 and (UM) 84-HUD, Mobile Home Approved.

NOTE: This installation must conform with local codes. In the absence of local codes you must comply with the UL1482-96, (UM) 84-HUD and NPFA211 in the U.S.A. and the ULC S627-00 and CAN/CSA-B365 Installation Codes in Canada.

B. BTU & Efficiency Specifications

EPA Certification #:	649
EPA Certified Emissions:	1.1 grams per hour
*LHV Tested Efficiency:	79.9%
**HHV Tested Efficiency:	74%
***EPA BTU Output:	11,700 to 32,000 / hr.
****Peak BTU/Hour Output:	57,200
Vent Size:	6 inches
Firebox Size:	2 cubic feet
Recommended Log Length:	16 inches
Fuel Orientation:	Front-to-Back
Fuel	Seasoned Cord Wood
*Weighted average LHV (Low Heating Value) efficiency using Douglas Fir dimensional lumber and data collected during EPA emission test. LHV assumes the moisture is already in a vapor state so there is no loss in energy to vaporize.	
**Weighted average HHV (High Heating Value) efficiency using Douglas Fir dimensional lumber and data collected during EPA emission test. HHV includes the energy required to vaporize the water in the fuel.	
***A range of BTU outputs based on EPA Default Efficiency and the burn rates from the low and high EPA tests, using Douglas Fir dimensional lumber.	
****A peak BTU out of the appliance calculated using the maximum first hour burn rate from the High EPA Test and the BTU content of cordwood (8600) times the efficiency.	

The Quadra-Fire Discovery II Wood Appliance (ACC) meets the U.S. Environmental Protection Agency's crib wood emission limits for wood appliances sold after May 15, 2015.

This wood appliance needs periodic inspection and repair for proper operation. It is against federal regulations to operate this wood appliance in a manner inconsistent with operating instructions in this manual.

C. Mobile Home Approved

- This appliance is approved for mobile home installations; when not installed in a sleeping room and when an outside combustion air inlet is provided.
- The structural integrity of the mobile home floor, ceiling, and walls must be maintained.
- The appliance must be properly grounded to the frame of the mobile home with #8 copper ground wire, and chimney must be listed to UL103 HT or a listed UL-1777 full length six inch (152mm) diameter liner must be used.
- Outside Air Kit, part OAK-ACC must be installed in a mobile home installation.

D. Glass Specifications

This appliance is equipped with 5mm ceramic glass. Replace glass only with 5mm ceramic glass. Please contact your dealer for replacement glass.



WARNING



Fire Risk.

Hearth & Home Technologies disclaims any responsibility for, and the warranty will be voided by, the following actions:

- Installation and use of any damaged appliance.
- Modification of the appliance.
- Installation other than as instructed by Hearth & Home Technologies.
- Installation and/or use of any component part not approved by Hearth & Home Technologies.
- Operating appliance without fully assembling all components.
- Operating appliance without legs attached (if supplied with appliance).
- Do NOT Overfire - If appliance or chimney connector glows, you are overfiring.

Any such action that may cause a fire hazard.

Improper installation, adjustment, alteration, service or maintenance can cause injury or property damage.

For assistance or additional information, consult a qualified installer, service agency or your dealer.



NOTE: Hearth & Home Technologies, manufacturer of this appliance, reserves the right to alter its products, their specifications and/or price without notice.

Quadra-Fire is a registered trademark of Hearth & Home Technologies.

User Guide

2 Operating Instructions

A. Over-Firing Your Appliance

 WARNING	
	Fire Risk
Do not over-fire. Over-firing may ignite creosote or will damage the appliance and chimney.	
To prevent over-firing your appliance, DO NOT:	
<ul style="list-style-type: none"> • Use flammable liquids • Overload with wood • Burn trash or large amounts of scrap lumber • Permit too much air to the fire 	

1. Symptoms of Over-Firing

Symptoms of over-firing may include one or more of the following:

- Chimney connector or appliance glowing
- Roaring, rumbling noises
- Loud cracking or banging sounds
- Metal warping
- Chimney fire

2. What To Do if Your Appliance is Over-Firing

- Immediately close the door and air controls to reduce air supply to the fire.
- If you suspect a chimney fire, call the fire department and evacuate your house.
- Contact your local chimney professional and have your appliance and appliance pipe inspected for any damage.
- Do not use your appliance until the chimney professional informs you it is safe to do so.

Hearth & Home Technologies WILL NOT warranty appliances that exhibit evidence of over-firing. Evidence of over-firing includes, but is not limited to:

- Warped air tube
- Deteriorated refractory brick retainers
- Deteriorated baffle and other interior components

B. Wood Selection & Storage

Burn only dry seasoned wood. Store wood under cover, out of the rain and snow. Dry and well-seasoned wood will not only minimize the chance of creosote formation, but will give you the most efficient fire. Even dry wood contains at least 15% moisture by weight, and should be burned hot enough to keep the chimney hot for as long as it takes to dry the wood out - about one hour. It is a waste of energy to burn unseasoned wood of any kind.

Dead wood lying on the forest floor should be considered wet, and requires full seasoning time. Standing dead wood can be considered to be about 2/3 seasoned. To tell if wood is dry enough to burn, check the ends of the logs. If there are cracks radiating in all directions from the center, it is dry. If your wood sizzles in the fire, even though the surface is dry, it may not be fully cured.

Splitting wood before it is stored reduces drying time. Wood should be stacked so that both ends of each piece are exposed to air, since more drying occurs through the cut ends than the sides. This is true even with wood that has been split. Store wood under cover, such as in a shed, or covered with a tarp, plastic, tar paper, sheets of scrap plywood, etc., as uncovered wood can absorb water from rain or snow, delaying the seasoning process.

C. Burning Process

In recent years there has been an increasing concern about air quality. Much of the blame for poor air quality has been placed on the burning of wood for home heating. In order to improve the situation, we at Quadra-Fire have developed cleaner-burning wood appliances that surpass the requirements for emissions established by our governing agencies. These wood appliances, like any other appliances, must be properly operated in order to insure that they perform the way they are designed to perform. Improper operation can turn most any wood appliance into a smoldering environmental hazard.

1. Kindling or First Stage

It helps to know a little about the actual process of burning in order to understand what goes on inside a appliance. The first stage of burning is called the kindling stage. In this stage, the wood is heated to a temperature high enough to evaporate the moisture which is present in all wood. The wood will reach the boiling point of water (212°F) and will not get any hotter until the water is evaporated. This process takes heat from the coals and tends to cool the appliance.

Fire requires three things to burn - fuel, air and heat. So, if heat is robbed from the appliance during the drying stage, the new load of wood has reduced the chances for a good clean burn. For this reason, it is always best to burn dry, seasoned firewood. When the wood isn't dry, you must open the air controls and burn at a high burn setting for a longer time to start it burning. The heat generated from the fire should be warming your home and establishing the flue draft, not evaporating the moisture out of wet, unseasoned wood, resulting in wasted heat.

2. Second Stage

The next stage of burning, the secondary stage, is the period when the wood gives off flammable gases which burn above the fuel with bright flames. During this stage of burning it is

very important that the flames be maintained and not allowed to go out. This will ensure the cleanest possible fire. If the flames tend to go out, it is set too low for your burning conditions. The air control located at the upper right hand corner is used to adjust for burn rates. This is called the Burn Rate Air Control. **Figure 9.1**

3. Final Stage

The final stage of burning is the charcoal stage. This occurs when the flammable gases have been mostly burned and only charcoal remains. This is a naturally clean portion of the burn. The coals burn with hot blue flames.

It is very important to reload your appliance while enough lively hot coals remain in order to provide the amount of heat needed to dry and rekindle the next load of wood. It is best to open the Burn Rate Air and Start-Up Air Controls **before reloading**. This livens up the coalbed and reduces excessive emissions (opacity/smoke). Open door slowly so that ash or smoke does not exit appliance through opening. You should also break up any large chunks and distribute the coals so that the new wood is laid on hot coals.

Air quality is important to all of us, and if we choose to use wood to heat our homes we should do so responsibly. To do this we need to learn to burn our appliances in the cleanest way possible. Doing this will allow us to continue using our wood appliances for many years to come.

D. Air Controls

Users will need to find their preferred setting between high and low based on desired heat output, installation configuration, and fuel type.

1. Burn Rate Air Control

This air supply enters at the upper front of the firebox, near the top of the glass door. This preheated air supplies the necessary fresh oxygen to mix with the unburned gases, helping to create second, third and fourth combustions. This air is regulated by the Burn Rate Air Control. When the control is moved all the way up it is on the High setting and when moved all the way down it is on the Low setting. **Figure 9.1**

2. Automatic Combustion Control System (ACC)

To engage the Automatic Combustion Control (ACC) timer system push the lever towards the back of the appliance to the "HI" position, then pull forwards towards the front of the appliance until the knob stops. The timer will slowly close in about 25 minutes. Use this feature when reloading fuel or if you want more air supplied to the fire. **Figure 9.3**

E. Using Burn Rate Air Control & ACC System

1. Start up and Reloading Fuel

Open both Burn Rate Air Control and ACC systems fully. To do this with the Burn Rate Air Controls push spring handle up to high. For the ACC timer system push knob towards back of appliance until the knob is located under the high position. **Figure 9.1**

2. Maximize Heat with The ACC System

To maximize heat output with the ACC timer System or also known as high burn push the ACC Air Control lever towards the back of the appliance and leave. This combined with having the main burn rate control lever pushed up will deliver the most amount of air needed to achieve the highest amount of heat output. **Figure 9.1**

3. Manual Timer Over-Ride

If you need to shut the ACC system off before it goes through the cycle of shutting itself off; 25 minutes, reach towards the back of the appliance on the right side and pull the lever towards the front of the appliance. **Figure 9.2**

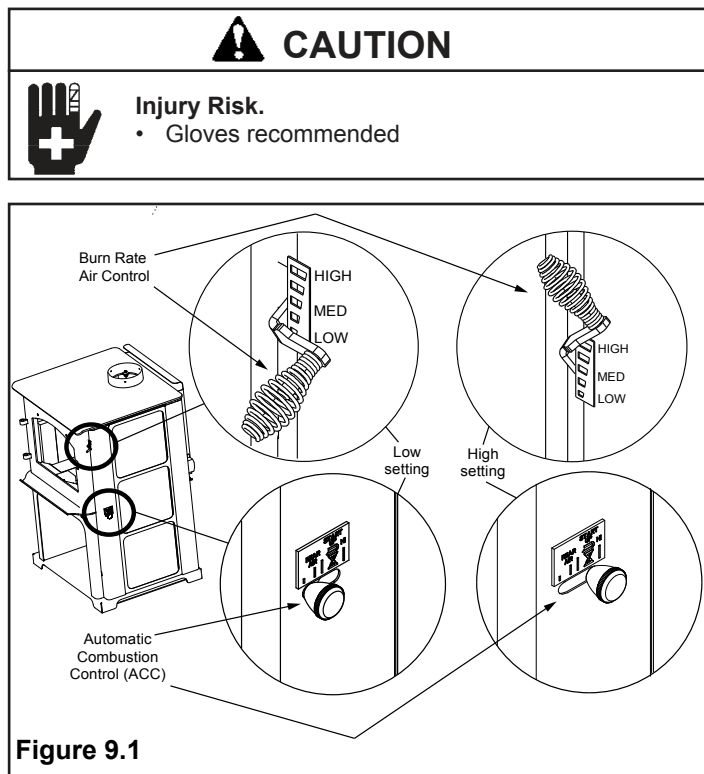

Figure 9.1

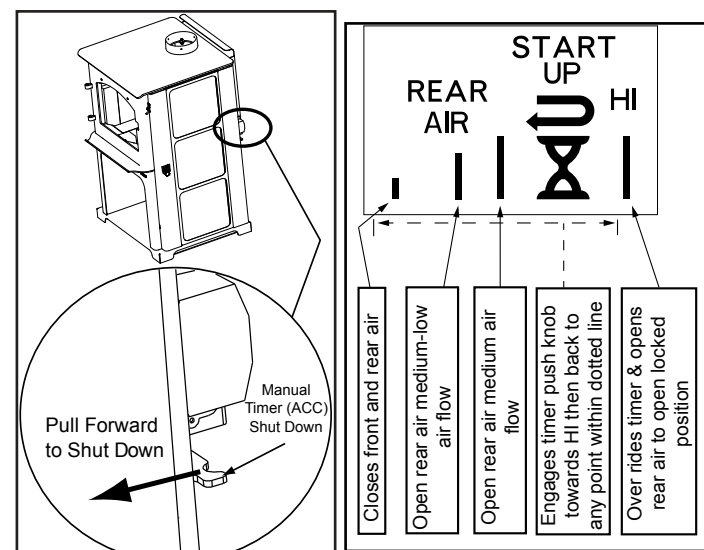

Figure 9.2

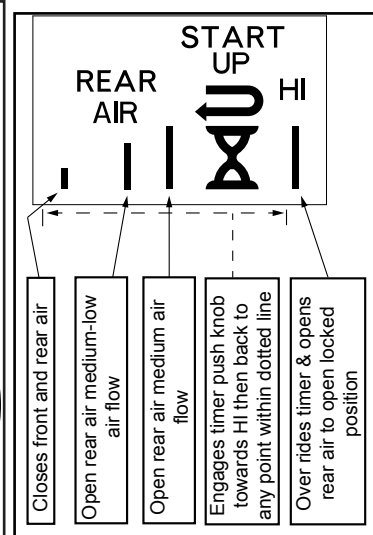

Figure 9.3

F. Burn Rates and Operating Efficiency

For maximum operating efficiency

This wood appliance has a manufacturer-set minimum low burn rate that must not be altered. It is against federal regulations to alter this setting or otherwise operate this wood appliance in a manner inconsistent with operating instructions in this manual.

- Burn dry, well-seasoned wood.

Burn Rates

1. Low burn setting:

- Burn Rate Air Control spring handle up to high position for 5 minutes.
- Then activate the ACC timer system by pushing the knob all the back toward the appliance to “HI” then pull forwards towards the front of the appliance until the knob stops (**Figure 9.1 on page 9**).
- At that point close the Burn Rate Air Control by moving the spring handle to the low setting.

2. Medium low burn setting:

- Burn Rate Air Control spring handle up to high position for 5 minutes.
- Then activate the ACC timer system by pushing the knob all the back toward the appliance to “HI” then pull forwards towards the front of the appliance until the knob stops.
- At that point move the Burn Rate Air Control spring handle to 1/8”-1/2” from the low setting.

3. Medium high burn setting:

- Burn Rate Air Control spring handle up to high position.
- Then activate the ACC timer system by pushing the knob all the back toward the appliance to “HI” then pull forwards towards the front of the appliance until the knob stops.
- At that point move the Burn Rate Air Control spring handle to 1/2” – high.

4. High burn setting:

- Burn Rate Air Control spring handle up to high position
- Also activate ACC timer system knob pushed back to the “HI” position.

Note: If using the optional blower use burn settings 1-3 burn settings the blower shall be off for the first 30 minutes and then be operated in the high position at 30 minutes. For high burn setting, blower may continue to be on full after the loading of the fuel.

NOTE: The above information is provided as a guideline only. Altitude and other circumstances may require control adjustments to achieve the desired burn rates.

NOTE: Operate appliance on High Burn 45 minutes a day to help keep flue/chimney clean.

WARNING



Risk of Fire.

When set on High Burn Rate and over-riding the Automatic Combustion Control system an overfire situation can occur and may result in a chimney fire.

Overfiring will void the appliance warranty.

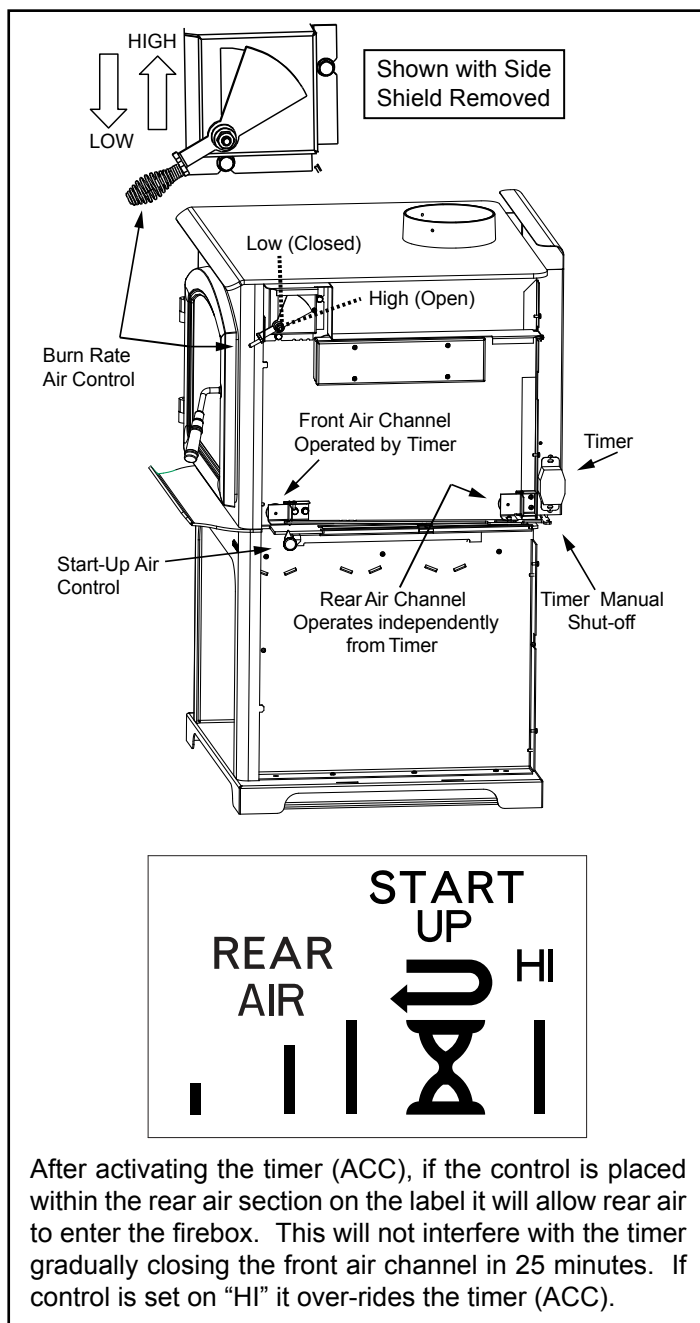

Figure 10.1

After activating the timer (ACC), if the control is placed within the rear air section on the label it will allow rear air to enter the firebox. This will not interfere with the timer gradually closing the front air channel in 25 minutes. If control is set on “HI” it over-rides the timer (ACC).

G. Building A Fire

Before lighting your first fire in the appliance:

NOTE: The special high temperature paint that your appliance is finished with will cure as your appliance heats. You will notice an odor and perhaps see some vapor rise from the appliance surface; this is normal. We recommend that you open a window until the odor dissipates and paint is cured.

1. Confirm the baffle is correctly positioned. It should be even with the front tube and resting on all tubes. **Figure 11.1 and 11.2 on page 11.**

2. Remove all labels from glass and inside of appliance.

There are many ways to build a fire. The basic principle is to light easily-ignitable tinder or paper, which ignites the fast burning kindling, which in turn ignites the slow-burning firewood. Here is one method that works well:

1. Open the Burn Rate Air and ACC Controls fully (Refer to page 6 Start-Up Guide).
2. Place several wads of crushed paper on the firebox floor. Heating the flue with slightly crumpled newspaper before adding kindling keeps smoke to a minimum.
3. Lay small dry sticks of kindling on top of the paper.
4. Make sure that no matches or other combustibles are in the immediate area of the appliance. Be sure the room is adequately ventilated and the flue unobstructed.
5. Light the paper in the appliance. NEVER light or rekindle fire with kerosene, gasoline, or charcoal lighter fluid; the results can be fatal.
6. Once the kindling is burning quickly, add several full-length logs 3 inches (76mm) or 4 inches (102mm) in diameter. Be careful not to smother the fire. Stack the pieces of wood carefully; near enough to keep each other hot, but far enough away from each other to allow adequate air flow between them.
7. Set the Burn Rate Air Control and activate the ACC timer system.
8. When ready to reload, it is best to fully open both the Burn Rate Air and Start-up Air Controls **before reloading**. This livens up the coal bed and reduces excessive emissions (opacity/smoke). Open door slowly so that ash or smoke does not exit appliance through opening. Large logs burn slowly, holding a fire longer. Small logs burn fast and hot, giving quick heat.
9. As long as there are hot coals, repeating steps 6 through 8 will maintain a continuous fire.

NOTE:

- Build fire on brick firebox floor.
- Do NOT use grates, andirons or other methods to support fuel. It will adversely affect emissions.



WARNING



Fire Risk

Do NOT store wood:

- Closer than required clearances to combustibles to appliance
 - Within space required for loading or ash removal.

Do NOT operate appliance:

- With appliance door open.
- With ash removal system door open.

Baffle Board even with front tube & resting on all tubes

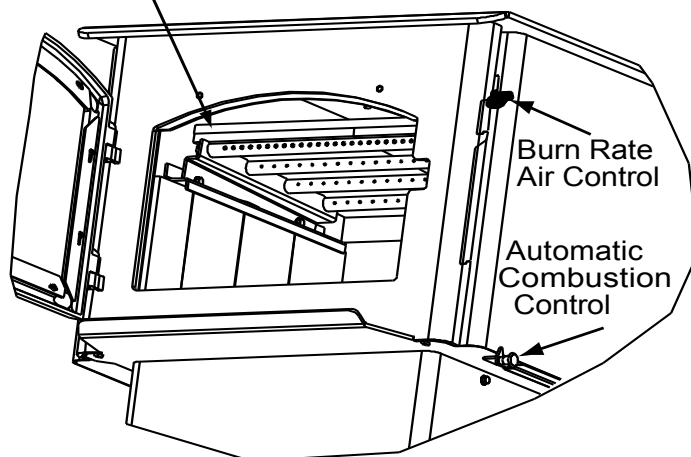

Ceramic Blanket on Top

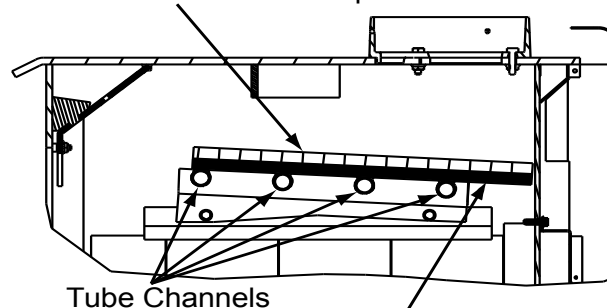

Figure 11.1



WARNING



Fire Risk.

- Do NOT burn wet or green wood.
- Store wood in dry location.
- Stack wood so both ends are exposed to air.

Wet, unseasoned wood can cause accumulation of creosote.

H. Correct Baffle & Blanket Placement

⚠ WARNING

Fire Risk
 Firebox damage due to improper baffle placement is not covered by warranty. Operate the wood burning appliance with the baffle in the correct position only.

Not doing so could result in:

- Reduced efficiency
- Overheating the chimney
- Overheating the rear of the firebox
- Poor performance

Ensure correct baffle placement and replace baffle components if damaged or missing.

CAUTION

The baffle boards are FRAGILE. Use extreme caution when loading firewood to prevent:

- Cracking, breaking or damaging the baffle boards

DO NOT operate the appliance without baffle boards

CORRECT POSITION

Ceramic Blanket and Baffle Board **MUST** be in contact with the back of the firebox and even in the front.

Figure 12.1

INCORRECT POSITIONS

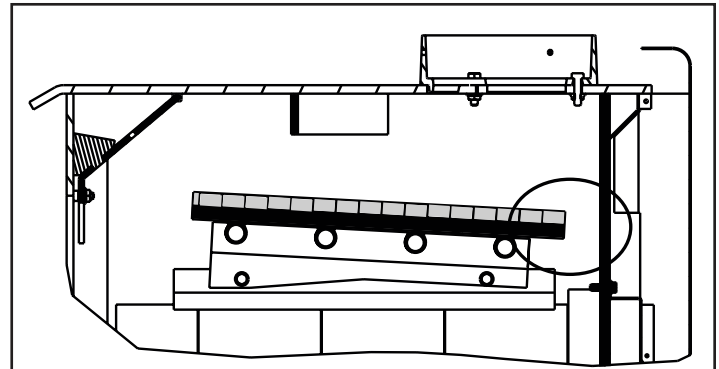

Ceramic Blanket and Baffle Board are **NOT** in contact with the back of the firebox.

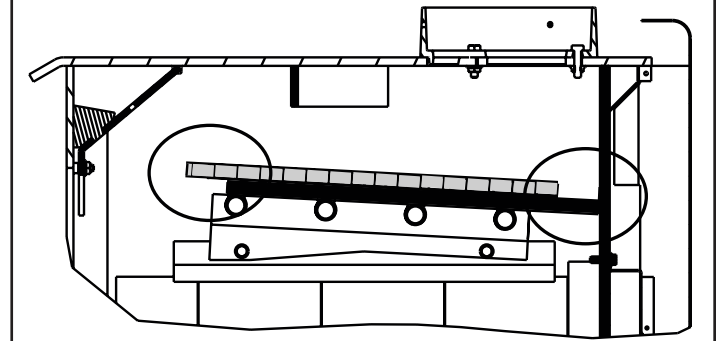

Ceramic Blanket is **NOT** in contact with the back of the firebox and **NOT** even with the Baffle Board in the front.

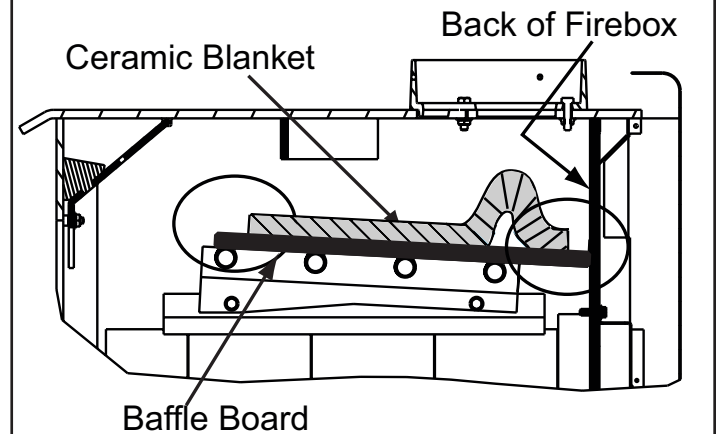

Ceramic Blanket is bunched up at the back of the firebox and **NOT** even with the Baffle Board in the front.

Figure 12.2

I. Blower Operating Instructions

NOTE: If your Quadra-Fire wood appliance is equipped with an optional blower, you should follow these guidelines:

1. Initial (cold) start-up and all Burn Settings

The blower can be plugged in and turned on right away. The blower fan is turned on and off by a snap disc. When your appliance has reached a certain temperature the blower will turn on and when your appliance has cooled down to a certain temperature it will turn off. Switch on blower control must be set to auto for this feature to work.

2. The blower is equipped with a speed control. Adjust the fan speed by turning the speed control clockwise to "Low" or counterclockwise to "High".

3. Snap Disc Location

If you find the blower coming on and off at undesirable temperatures, relocate the snap disc to another location in the designated zone on the back of the appliance.

Figure 13.1 There is a manual over-ride switch to deactivate the snap disc, if necessary.

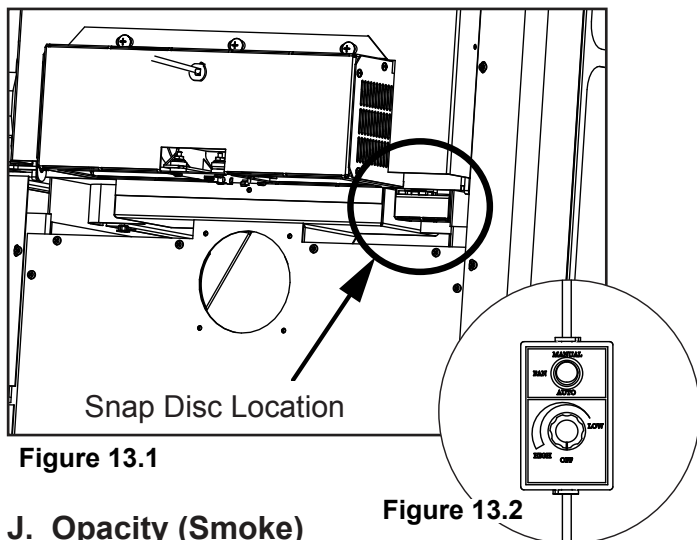



Figure 13.1

Figure 13.2

J. Opacity (Smoke)

This is the measure of how cleanly your appliance is burning. Opacity is measured in percent; 100% opacity is when an object is totally obscured by the smoke column from a chimney, and 0% opacity means that no smoke column can be seen. As you become familiar with your appliance, you should periodically check the opacity. This will allow you to know how to burn as nearly smoke-free as possible (goal of 0% opacity).

⚠ WARNING



Fire Risk.

- DO NOT BURN GARBAGE OR FLAMMABLE FLUIDS SUCH AS GASOLINE, NAPHTHA OR ENGINE OIL.
- Do NOT burn treated wood or wood with salt (driftwood).
- May generate carbon monoxide if burn material other than wood.

May result in illness or possible death.

⚠ WARNING



Fire Risk.

Keep combustible materials, gasoline and other flammable vapors and liquids clear of appliance.

- Combustible materials may ignite.
- Do NOT store flammable materials in the appliance's vicinity.
- DO NOT USE GASOLINE, LANTERN FUEL, KEROSENE, CHARCOAL LIGHTER FLUID OR SIMILAR LIQUIDS TO START OR "FRESHEN UP" A FIRE IN THIS APPLIANCE.
- Keep all such liquids well away from the appliance while it is in use.

CAUTION

When burning your first fire, you will experience smoke and odor from the appliance resulting from the curing of paint and burning off of any oils remaining from manufacturing.

OPEN WINDOWS DURING INITIAL BURN TO DISSIPATE SMOKE AND ODORS!

- Odors may be irritating to sensitive individuals.
- Smoke detectors may activate.

K. Clear Space



- Do NOT place combustible objects within 4 ft (1.2 m) of the front of appliance. See **Figure 13.3**.
- Mantel - avoid placing candles and other heat-sensitive objects on mantel or hearth. Heat may damage these objects.

⚠ WARNING

DO NOT PLACE COMBUSTIBLE OBJECTS IN FRONT OF THE APPLIANCE. High temperatures may ignite clothing, furniture or draperies.

Figure 13.3

L. Negative Pressure

 WARNING	
	<p>Asphyxiation Risk.</p> <ul style="list-style-type: none"> Negative pressure can cause spillage of combustion fumes, soot and carbon monoxide. Appliance needs to draft properly for safety.

Negative pressure results from the imbalance of air available for the appliance to operate properly. It can be strongest in lower levels of the house.

Causes include:

- Exhaust fans (kitchen, bath, etc.)
- Range hoods
- Combustion air requirements for furnaces, water appliances and other combustion appliances
- Clothes dryers
- Location of return-air vents to furnace or air conditioning
- Imbalances of the HVAC air handling system
- Upper level air leaks such as:
 - Recessed lighting
 - Attic hatch
 - Duct leaks



To minimize the effects of negative air pressure:



- Install the outside air kit with the intake facing prevailing winds during the heating season
- Ensure adequate outdoor air for all combustion appliances and exhaust equipment
- Ensure furnace and air conditioning return vents are not located in the immediate vicinity of the appliance
- Avoid installing the appliance near doors, walkways or small isolated spaces
- Recessed lighting should be a “sealed can” design
- Attic hatches weather stripped or sealed
- Attic mounted duct work and air handler joints and seams taped or sealed

M. Frequently Asked Questions

ISSUES	SOLUTIONS
Odor from appliance	When first operated, this appliance may release an odor for the first several hours. This is caused by the curing of the paint and the burning off of any oils remaining from manufacturing.
Metallic noise	Noise is caused by metal expanding and contracting as it heats up and cools down, similar to the sound produced by a furnace or heating duct. This noise does not affect the operation or longevity of the appliance.
Whirring sound	If the optional blower has been installed, the blower produces a whirring sound which increases in volume as the speed is increased.

CONTACT YOUR DEALER for additional information regarding operation and troubleshooting.
Visit www.quadrafire.com to find a dealer.

 WARNING	
	<p>Fire Risk.</p> <ul style="list-style-type: none"> DO NOT BURN GARBAGE OR FLAMMABLE FLUIDS SUCH AS GASOLINE, NAPHTHA OR ENGINE OIL. Do NOT burn treated wood or wood with salt (driftwood). May generate carbon monoxide if burn material other than wood. <p>May result in illness or possible death.</p>

 WARNING	
	<p>Fire Risk.</p> <p>Keep combustible materials, gasoline and other flammable vapors and liquids clear of appliance.</p> <ul style="list-style-type: none"> Do NOT store flammable materials in the appliance’s vicinity. DO NOT USE GASOLINE, LANTERN FUEL, KEROSENE, CHARCOAL LIGHTER FLUID OR SIMILAR LIQUIDS TO START OR “FRESHEN UP” A FIRE IN THIS APPLIANCE. Keep all such liquids well away from the appliance while it is in use. Combustible materials may ignite.

3 Maintenance and Service

A. Quick Reference Maintenance Guide

CAUTION! Allow the appliance to completely cool down before performing any cleaning or maintenance.

Start the first inspection after the first 2 months of use, or if performance changes, and adjust your schedule accordingly. Maintenance is required for safe operation and must be performed to maintain your warranty.

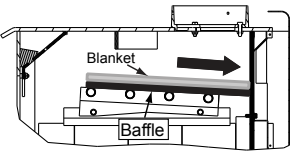
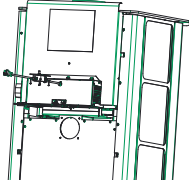
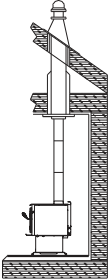
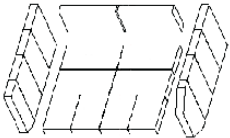
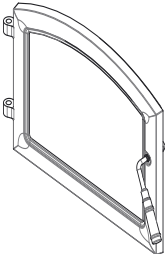
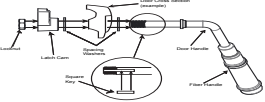
Baffle & Blanket	Frequency	Task
	MONTHLY, After Every Cord of Wood, OR After Each Cleaning	Baffle and blanket placement is critical to heat output, efficiency and overall life of the appliance. Make sure the baffle is pushed all of the way to the back of the firebox and the blanket is laying flat. Inspect baffle for cracks.
	YEARLY	Vacuum the blower impellers.
	EVERY 2 MONTHS or After Every 2 Cords of Wood	The chimney and chimney cap must be inspected for soot and creosote every two months during the burn season or more frequency if chimney exceeds or is under 14-16 ft (4.3m-4.8m) measured from bottom of appliance. This will prevent pipe blockage, poor draft, and chimney fires. Always burn dry wood to help prevent cap blockage and creosote build-up.
	WEEKLY or After Every 25 Loads of Wood	Ashes must be cool before you can dispose of the ashes in a non-combustible container. Firebrick is designed to protect your firebox. After ashes are removed, inspect the firebrick and replace firebricks that are crumbling, cracked or broken.
	WEEKLY or After Every 25 Loads of Wood	Keep door and glass gasket in good shape to maintain good burn times on a low burn setting. To test: place a dollar bill between the appliance and door and then shut the door. If you can pull the dollar out, remove one washer from door handle behind latch cam and try again. If you can still pull it out, replace the door gasket. Check the glass frame for loose screws to prevent air leakage. Check glass for cracks.
	YEARLY	Check the door latch for proper adjustment. This is very important especially after the door rope has formed to the appliance face. Check door handle for smooth cam operation.

These are generic drawings and may not represent your model.

Discovery II

B. General Maintenance

1. Creosote (Chimney) Cleaning

- **Frequency:** Every 2 months during heating season or as recommended by a certified chimney sweep; more frequently if chimney exceeds or is under 14-16 ft. (measured from bottom of appliance)
- **By:** Certified Chimney Sweep

Remove all ash from the firebox and extinguish all hot embers before disposal. Allow the appliance to cool completely. Disconnect flue pipe or remove baffle and ceramic blanket from appliance before cleaning chimney. Otherwise residue can pile up on top of the baffle and ceramic blanket and the appliance will not work properly. (See Baffle Removal on **page 19**). Close the door tightly. The creosote or soot should be removed with a brush specifically designed for the type of chimney in use. Clean out fallen ashes from the firebox.





It is also recommended that before each heating season the entire system be professionally inspected, cleaned and repaired if necessary.

Inspection: Inspect the system at the appliance connection and at the chimney top. Cooler surfaces tend to build creosote deposits quicker, so it is important to check the chimney from the top as well as from the bottom.

Formation and Need For Removal: When wood is burned slowly, it produces tar and other organic vapors which combine with expelled moisture to form creosote.

The creosote vapors condense in the relatively cool chimney flue of a newly-started or a slow-burning fire. As a result, creosote residue accumulates on the flue lining. When ignited, this creosote creates an extremely hot fire which may damage the chimney or even destroy the house.

The chimney connector and chimney should be inspected once every 2 months during the heating season to determine if a creosote or soot buildup has occurred. If creosote or soot has accumulated, it should be removed to reduce the risk of a chimney fire.

 WARNING	
	Fire Risk. Prevent creosote buildup. • Inspect chimney connector and chimney once every two months during heating season.
	<ul style="list-style-type: none">• Remove creosote to reduce risk of chimney fire.• Ignited creosote is extremely HOT.
 WARNING	
	Fire Risk. • Do not use chimney cleaners or flame colorants in your appliance. Will corrode chimney pipe.

2. Cleaning Plated Surfaces

- **Frequency:** Prior to first burn and then as desired
- **By:** Homeowner

Clean all the fingerprints and oils from plated surfaces **BEFORE** firing the appliance for the first time. If not cleaned properly before lighting your first fire, the oils can cause permanent markings on the plating.



After the plating is cured, the oils will not affect the finish and little maintenance is required. Wipe clean as needed.

CAUTION	
<ul style="list-style-type: none">• Do not use polishes with abrasives. It will scratch plated surfaces.	

3. Disposal of Ashes

- **Frequency:** When ash is within 1-3/4 in. (44mm) of firebox lip
- **By:** Homeowner

Ashes should be placed in a metal container with a tight fitting lid. The closed container of ashes should be placed on a non-combustible floor or on the ground, well away from all combustible materials, pending final disposal. If the ashes are disposed of by burial in soil or otherwise locally dispersed, they should be retained in the closed container until all cinders have thoroughly cooled.

 WARNING	
	Fire Risk. Disposal of Ashes
	<ul style="list-style-type: none">• Ashes should be placed in metal container with tight fitting lid.• Do not place metal container on combustible surface.• Ashes should be retained in closed container until all cinders have thoroughly cooled.

4. Glass Cleaning

- **Frequency:** As desired
- **By:** Homeowner

Clean glass with a non-abrasive glass cleaner. Abrasive cleaners may scratch and cause glass to crack. If the deposits on the glass are not very heavy, normal glass cleaners work well. Heavier deposits may be removed by using a damp cloth dipped in wood ashes or by using a commercially available oven cleaner.

After using an oven cleaner, it is advisable to remove any residue with a glass cleaner or soap and water. Oven cleaner left on during the next firing can permanently stain the glass and damage the finish on metal surfaces.

A portion of the combustion air entering the firebox is deflected down over the inside of the door glass. This air flow "washes" the glass, helping to keep smoke from adhering to its surface.

When operated at a low burn rate, less air will be flowing over the glass and the smokey, relatively cool condition of a low fire will cause the glass to become coated.

Operating the appliance with the Burn Rate Air Control and Start-Up Air Control all the way open for 30-45 minutes should remove the built up coating.

CAUTION	
<ul style="list-style-type: none">• Do not use polishes with abrasives. It will scratch surfaces.	

4 Troubleshooting Guide

With proper installation, operation, and maintenance your wood appliance will provide years of trouble-free service. If you do experience a problem, this troubleshooting guide will assist you or a qualified service person in the diagnosis of a problem and the corrective action to be taken.

Start Fire Problems	Possible Cause	Solution
Can not get fire started Excessive smoke or spillage Burns too slowly Not enough heat output	Not enough kindling/paper or no kindling/paper	Use dry kindling, more paper. Arrange kindling & wood for air movement.
	Not enough air for fire to ignite	Check for restricted termination cap
		Check for blockage of outside air kit (if installed).
		Check for flue blockage.
		Pre-warm flue before starting fire (refer to Building a Fire Section).
		Check for adequate vent height (refer to Chimney Height Section).
	Open window below the appliance towards the wind.	
	Wood condition is too wet, too large	Use dry, seasoned wood (refer to Seasoned Wood Section).
	Bed of coals not established before adding wood	Start with paper & kindling to establish bed of coals (refer to Building a Fire Section).
Flue blockage such as birds' nests or leaves in termination cap	Have chimney inspected for creosote and cleaned by a certified chimney sweep.	
Down draft or negative pressure Competition with exhaust devices	Do not use exhaust fans during start-up (refer to Negative Pressure Section).	
	Open window below the appliance towards the wind.	
Fire burns too fast	Extremely dry or soft wood	Mix in hardwood.
		Mix in less seasoned wood after fire is established (refer to Wood Fuel Section).
	Overdrafting	Check for correct vent height; too much vertical height creates overdrafting.
		Check location of vent termination (refer to Chimney Termination Requirement Section).

5 Service Part Replacement

A. Glass Replacement

1. Ensure that the fire is out and the appliance is cool to the touch.
2. Protect a table or counter top with padding or towels. Protect your hands and wear gloves to prevent injury.
3. Remove the door with the broken glass by lifting the door up and off of the hinges.
4. Lay door face down on a table or counter making sure the handle hangs over the edge so the door lays flat, on a soft surface.
5. Remove the screws from each glass retainer and remove the glass. (If screws are difficult to remove, soak with penetrating oil first).
6. Center the glass with edges evenly overlapping the opening in the door, (i.e. same space top and bottom, left and right sides).
7. Replace the glass retainers. Be careful not to cross thread the screws.
8. Tighten each retainer just a few turns until each is secured. Check again for centering of glass in door frame. Continue to tighten each retainer alternately, a few turns at a time, until the glass is secure. **DO NOT OVERTIGHTEN.**
9. Replace the door on the appliance.

Quadra-Fire appliances are equipped with ceramic super heat-resistant glass, which can only be broken by impact or misuse. Do not slam appliance door or impact the glass. When closing door, make sure that logs do not protrude against the glass. Inspect glass regularly. If you find a crack or break, immediately put the fire out and return the door to your dealer for replacement of glass before further use.

CAUTION

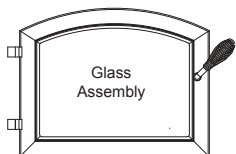

Handle glass assembly with care.

When cleaning glass:

- Avoid striking, scratching or slamming glass.

- Do NOT clean glass when hot.
- Do NOT use abrasive cleaners.
- Use a hard water deposit glass cleaner on white film.
- Use commercial oven cleaner on heavier deposits.
- Remove all residue of oven cleaner or will permanently stain glass on next firing. **Refer to maintenance instructions.**



WARNING



Injury Risk.

- Use only glass specified in manual.
- DO NOT REPLACE with any other material.

B. Firebrick Replacement

Replace the firebrick if they become crumbly and/or if there is a 1/4 inch (6.35mm) gap between the bricks.

Inspect the firebrick after each ash removal.

The firebox is lined with high quality firebrick, which has exceptional insulating properties. There is no need to use a grate; simply build a fire on the firebox floor. Do not operate appliance without firebrick.

1. After the coals have completely cooled, remove all old brick and ash from appliance and vacuum firebox.
2. Remove new brick set from box and lay out to diagram shown.
3. Lay bottom bricks in appliance.
4. Install rear bricks on the top of the bottom bricks. Slide top of bricks under clip on back of firebox wall and push bottom of brick back.
5. Install side bricks. Slide top of brick under clips on side of firebox and push the bottom of the brick until it is flush with the side of the appliance.

C. Snap Disc Replacement

(included with optional blower)

1. Unplug the appliance.
2. Locate the snap disc bracket assembly at the bottom left rear corner of the appliance.
3. A magnet holds the bracket to the appliance. Pull the bracket down away from the appliance to expose the snap disc.
4. Pull the snap disc and spade connectors up and out of bracket as shown in **Figure 18.1**
5. Using a Phillips head screw driver, remove the 2 screws from the snap disc and then remove the snap disc from the spade connectors. Replace with new snap disc and re-connect to spade connectors.
6. Push the snap disc and spade connectors back inside bracket. Reassemble in reverse order.

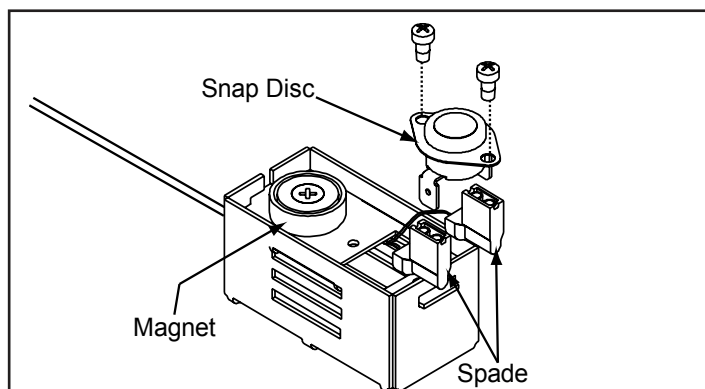

Figure 18.1

D. Door Handle Assembly

1. Slide door handle through door.
2. Install additional washer(s) as shown in **Figure 19.1**
3. Install key in groove.
4. Align groove in latch cam with key; slide latch cam over shaft
5. Install locknut but do not overtighten, the handle needs to rotate smoothly.
6. Install fiber handle. **Figure 19.1**

CAUTION! Do not overtighten lock nut. The door handle needs to move smoothly.

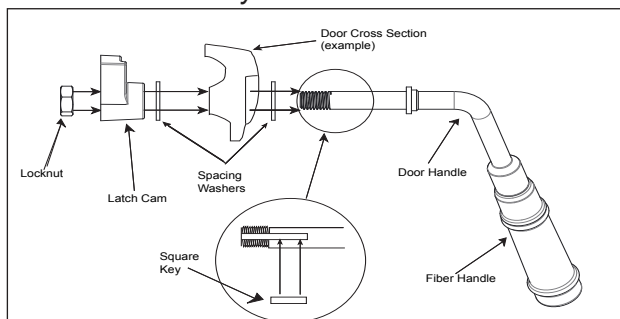

Figure 19.1

E. Baffle Removal

1. Remove all ash from the firebox, and extinguish all hot embers before disposal into a metal container.
2. The baffle board has 2 pieces. With the ceramic blanket still in place, slide one baffle piece over the top of other one and pull out top piece through the door opening and then remove bottom baffle piece. **Figure 19.2.**
3. Remove the ceramic blanket.
4. Re-install the ceramic blanket and smooth out the blanket.
4. Slide the baffle pieces one piece at a time underneath the blanket. Be sure the baffle boards are even with the front manifold tube and is resting on all tubes. **Figures 19.2 and 19.3.**



Figure 19.2

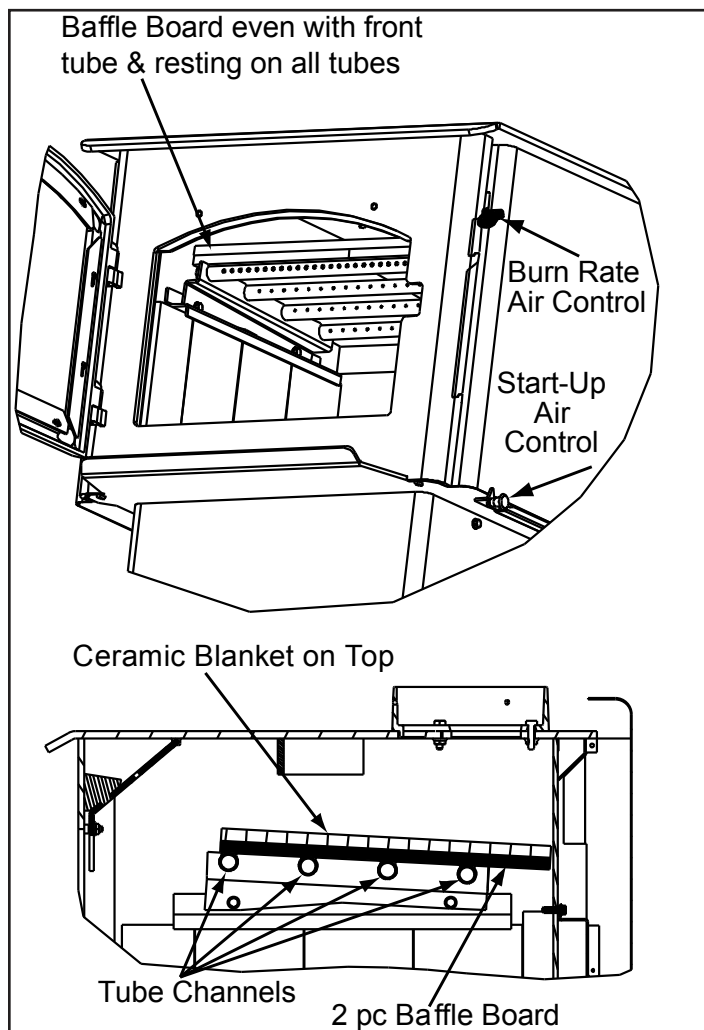

Figure 19.3

F. Decorative Panel Removal & Installation

Your appliance ships with two different side options, one is a solid side panel (**Figure 20.1**) and tile side panel (**Figure 20.2**). There are two of each and no left or right side, these can be changed at anytime.

Solid Side Panel Removal

1. Remove solid panel from side by lifting up and pulling away from appliance (use a flat tool to pry from bottom if needed).

Figure 20.3

Note: 300 degree F high temp paint can be use to repaint the solid side panel only! DO NOT use on the rest of appliance this requires 1200 degree F high temp paint.

Tile Panel Installation

1. Remove tile frame from side by lifting up and pulling away from appliance. **Figure 20.3 reference solid side panel removal.**
2. Stack non-combustible material tiles in tile frame as shown in **Figure 20.2.**
3. Reattach tile frame **Figure 20.4.**

Tile Dimensional Requirements:

Max Thickness: 5/16"

Max Length/Width: 11-7/8" square

Min Length/Width: 11-11/16" square

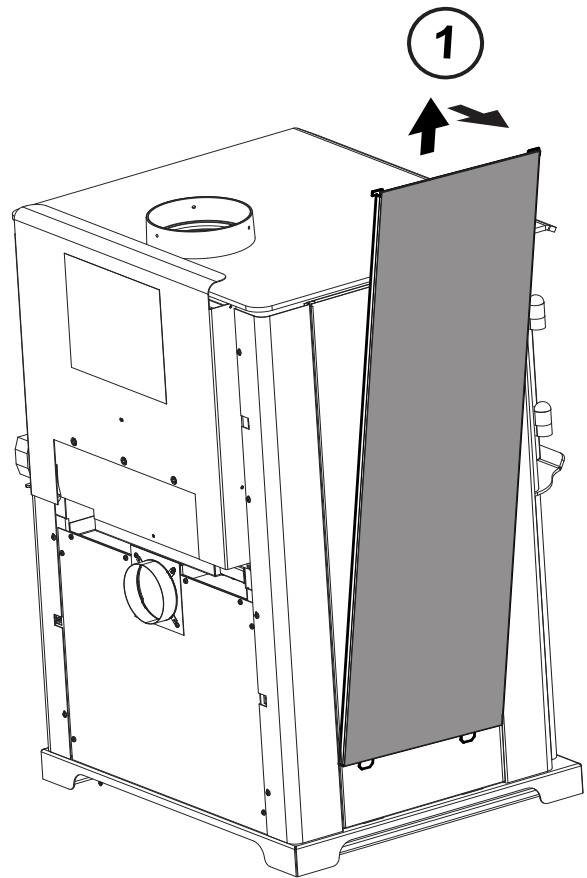

Figure 20.3

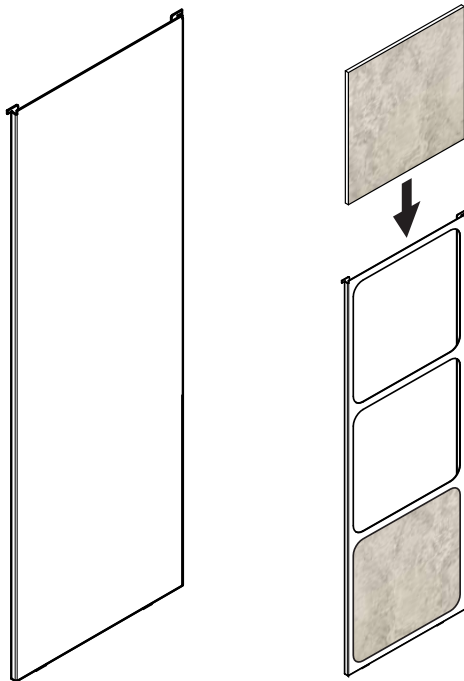

Figure 20.1

Figure 20.2

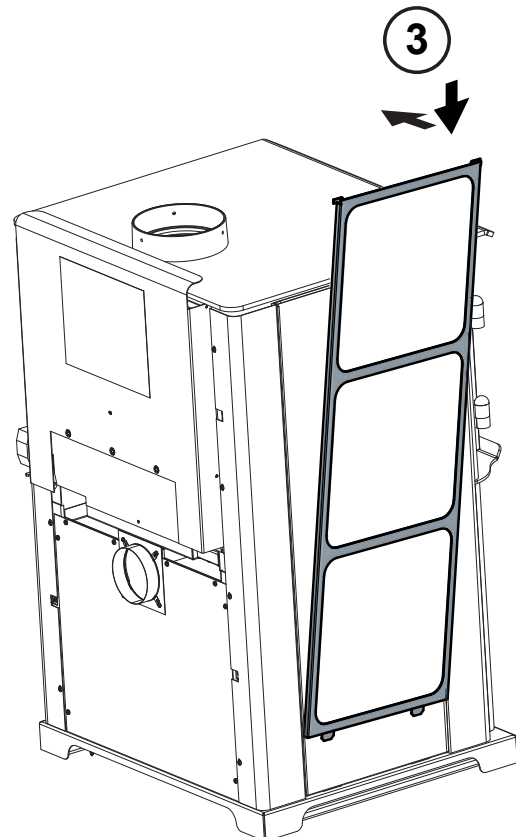

Figure 20.4

WARNING!

Use only noncombustible materials as a decorative tile.

G. Tube Channel Assembly Replacement

Removing Tube Channel Assembly

1. Remove the right side shield by lifting up on side to remove.
2. Remove 4 screws from channel access cover and remove cover.
3. Locate 2 channel nuts inside of chamber and remove using a 7/16 socket wrench. Slide out tube channel assembly.

NOTE: Soak the bolts with penetrating oil for at least 15 minutes before trying to remove them.

Replacing Tube Channel Assembly

1. Slide one gasket onto each tube.
2. Slide the tube channel assembly into side of firebox and insert each tube into the corresponding hole in the tube channel rack starting with the back hole first.
3. Make sure tube channel assembly is flush against the side of the appliance and secure with channel nuts.
4. Re-install channel cover and side shield.

NOTE: Service Space

In order to replace the tube channel assembly a clearance of 19 inches (483mm) is required on the right side of appliance in order to remove the tubes with the appliance in place.

If space is not available, the appliance will have to be disconnected from the chimney to proceed with the tube replacement.

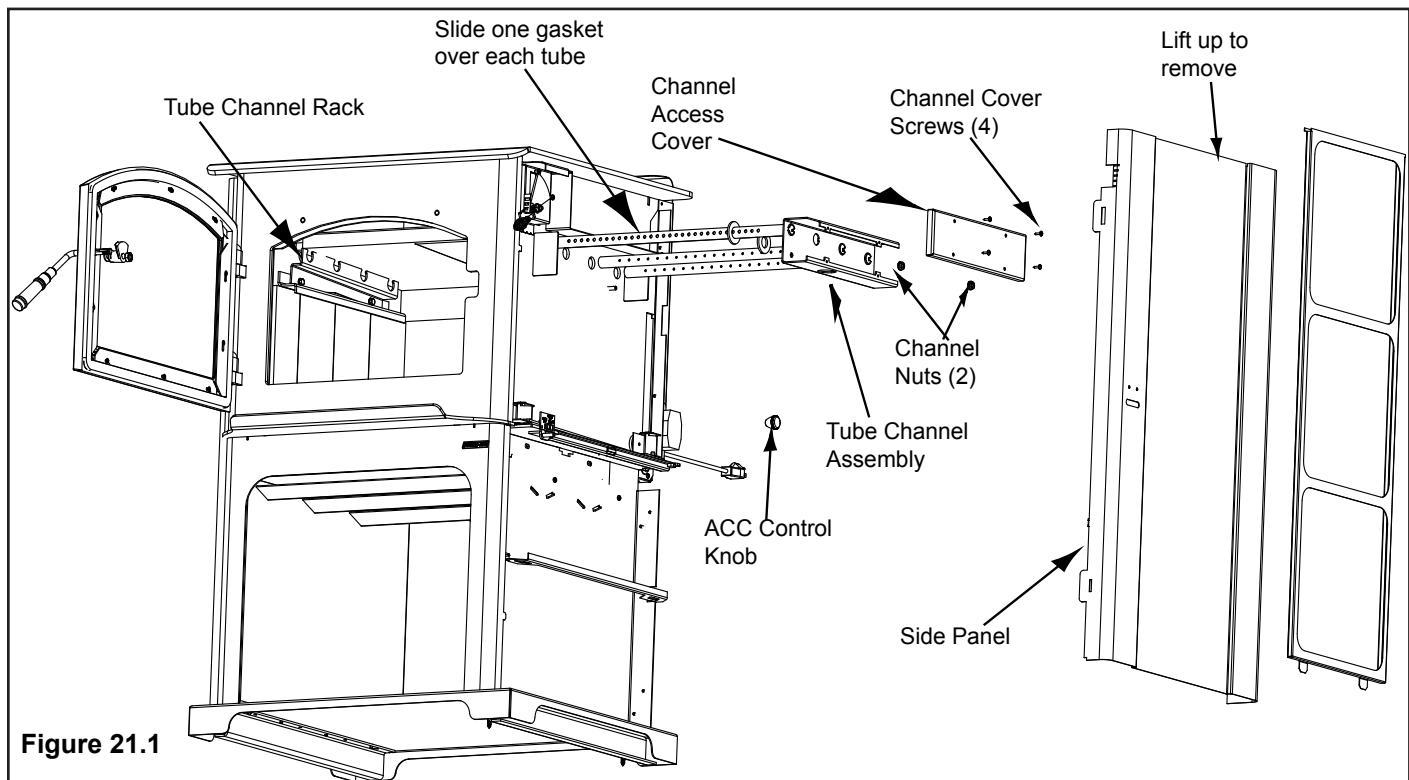

Figure 21.1

B. Service Parts & Accessories



Service Parts

DISCOVERY-II

Wood Stove

Beginning Manufacturing Date: Aug 2016
Ending Manufacturing Date: Active

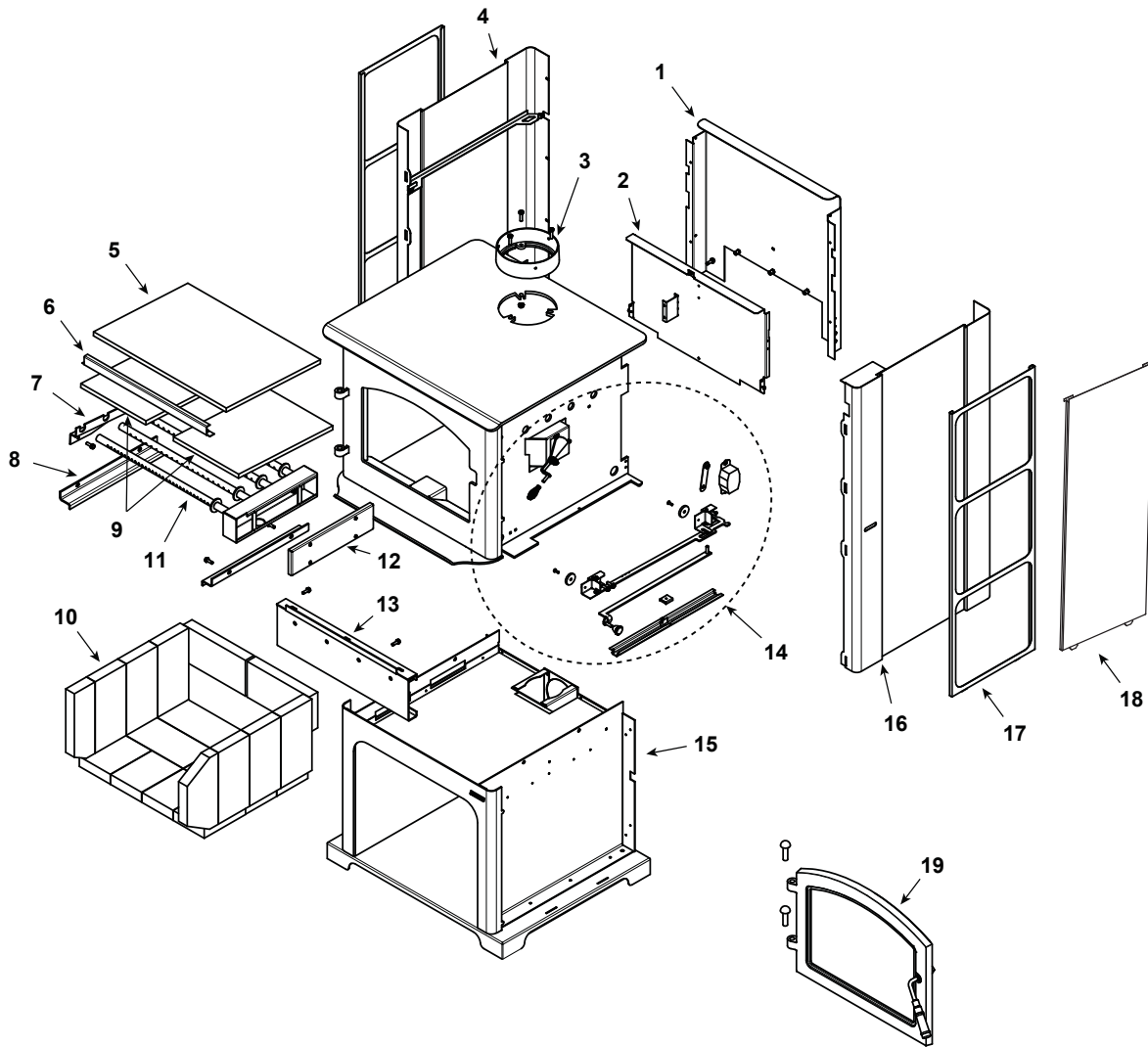

Part number list on following page.

08/16

IMPORTANT: THIS IS DATED INFORMATION. Parts must be ordered from a dealer or distributor. **Hearth and Home Technologies does not sell directly to consumers.** Provide model number and serial number when requesting service parts from your dealer or distributor.



Stocked at Depot

ITEM	DESCRIPTION	COMMENTS	PART NUMBER	
1	Air Channel, Convection w/Bracket (Retain Original SN Label)		SRV7033-144	
2	Air Supply Back		SRV7033-134	
3	Flue Collar		SRV7000-302	
4	Panel Assembly, Side, Left		SRV7033-082	Y
5	Ceramic Fiber Blanket, 1/2" Thick		832-3390	
6	Baffle Protection Channel		SRV7033-298	
7	Tube Support Rack		7033-148	
8	Brick Retainer		7033-149	
9	Baffle Board	Pkg of 2	SRV7033-209	

#10 Brick Set Assembly

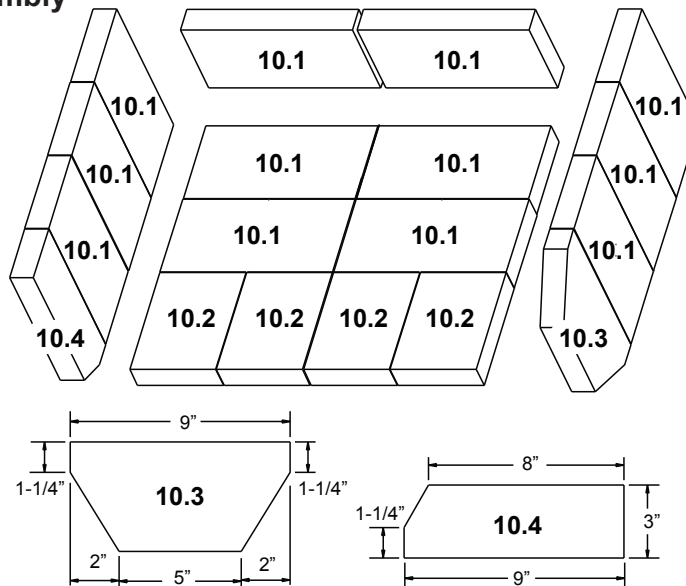

10	Firebrick Set, Complete Set		SRV7033-006	
10.1	Brick, 9 x 4-1/2 x 1-1/4"	Qty. 12 Req.		
10.2	Brick, 6 x 4-1/2 x 1-1/4"	Qty. 4 Req.		
10.3	Brick, 9 x 4-1/2 x 1-1/4" w/angles, see diagram	Qty. 1 Req.		
10.4	Brick, 9 x 3 x 1-1/4" w/angle, see diagram	Qty. 1 Req.		
	Brick, Uncut	Pkg of 1	832-0550	
		Pkg of 6	832-3040	
11	Tube, Channel Assembly		SRV7033-023	
12	Tube Channel Top		SRV7033-237	Y
13	Rear Channel Assembly		7033-002	Y

Additional service part numbers appear on following page.

Beginning Manufacturing Date: Aug 2016
 Ending Manufacturing Date: Active

IMPORTANT: THIS IS DATED INFORMATION. Parts must be ordered from a dealer or distributor. **Hearth and Home Technologies does not sell directly to consumers.** Provide model number and serial number when requesting service parts from your dealer or distributor.

**Stocked
at Depot**

ITEM	DESCRIPTION	COMMENTS	PART NUMBER	
#14 Burn Rate Control Assembly				
14.1	Burn Rate Control Assembly		7033-033	Y
14.2	Spring Handle, 1/4"		250-8340	Y
14.3	Door Gasket		7033-282	Y
14.4	Timer Air Control Assembly		SRV7033-052	Y
14.5	Control Arm Assembly, Rear Air		SRV7033-079	
14.6	Knob		7000-343	
14.7	Air Control Rod Guide		7033-210	
14.8	Latch, Magnet		229-0631	
14.9	Timer Arm Assembly		7033-034	Y
14.10	Timer (Only) Replacement Assembly		SRV480-1940	Y
15	Pedestal Assembly		SRV7033-072	
	Logo, Quadra-Fire	Pkg of 10	7000-649/10	
16	Panel Assembly, Side Right		SRV7033-080	
17	Tile Frame		SRV7033-324	
18	Blank Frame		SRV7033-346	

Additional service part numbers appear on following page.



IMPORTANT: THIS IS DATED INFORMATION. Parts must be ordered from a dealer or distributor. **Hearth and Home Technologies does not sell directly to consumers.** Provide model number and serial number when requesting service parts from your dealer or distributor.



Stocked at Depot

ITEM	DESCRIPTION	COMMENTS	PART NUMBER	
#19 Door Assembly				
19	Door Assembly		DR-31/43BK-FH	
19.1	Hinge Pin, 1/2"		430-5320	
19.2	Rope, Door, 3/4" x 84"	7 Ft.	832-1680	Y
19.3	Door Glass Assembly		7000-012	Y
	Gasket, Glass Tape, 3/4" x 1/8"	5 Ft.	832-0460	Y
19.4	Glass Frame Set	4 pcs.	832-0350	
19.5	Door Handle Assembly		SRV7033-071	
	Door Handle		SRV7044-188	Y
	Fiber Handle		SRV7060-212	
	Washer, Sae, 3/8 (3 Ea)	Pkg of 3	832-0990	
	Cam Latch		430-1141	
	Key, Cam Latch		430-1151	
	Nut, 2-Wy Side-Lock Jam 3	Pkg of 24	226-0100/24	Y
	Screw Flat Head Phillips 8-32 x 1/2	Pkg of 10	220-0490/12	Y
	Component Pack Assembly		SRV7033-083	
	Paint, Touch-Up		812-0910	

Additional service part numbers appear on following page.

QUADRA-FIRE®

NOTHING BURNS LIKE A QUAD

CONTACT INFORMATION

Hearth & Home Technologies
1445 North Highway
Colville, WA 99114
Division of HNI INDUSTRIES

Please contact your Quadra-Fire dealer with any questions or concerns.
For the number of your nearest Quadra-Fire dealer
log onto www.quadrafire.com

CAUTION



DO NOT DISCARD THIS MANUAL

- Important operating and maintenance instructions included.
- Read, understand and follow these instructions for safe installation and operation.
- Leave this manual with party responsible for use and operation.

DO NOT
DISCARD

We recommend that you record the following pertinent information for your heating appliance.

Date purchased/installed: _____

Serial Number: _____ Location on appliance: _____

Dealership purchased from: _____ Dealer phone: _____

Notes: _____

This product may be covered by one or more of the following patents: (United States) 5341794, 5263471, 6688302, 7216645, 7047962 or other U.S. and foreign patents pending.