



PELLET INSERTS

QUADRA-FIRE[®]
NOTHING BURNS LIKE A QUAD

QUADRA-FIRE®

PERFORMANCE FROM THE BEGINNING



Founders Alan Trusler and Dan Henry spent countless nights in the lab, determined to harness the powerful force of fire in ground-breaking new ways. In 1990 they introduced the first self-igniting pellet stove using Original Energy Technology, followed in 1996 by the most advanced pellet stove seen using Advanced Energy technology. In 2014 Quadra-Fire launched Efficient Energy technology. The tradition lives on through these pellet appliances.

WHY QUADRA-FIRE

For more than 30 years, Quadra-Fire has put performance and easy operation above all else. Today these ideals are vibrant and alive, blending our past with our present. Quadra-Fire products are proudly built to last by our members.

WHY PELLETS

Clean-burning and consistent, pellets are affordable, available and renewable. Automatic thermostats and temperature controls do the work for you—just keep your hopper filled. Pellets are normally available in 40 lb bags. A 1,500 sq ft home will use 2-4 tons per season, on average.

WHY AN INSERT

Quadra-Fire pellet inserts provide an instant upgrade to any hearth, designed to be retrofitted into an existing wood-burning fireplace. Inserts instantly transform your drafty old fireplace into a powerful, efficient and clean burning heat source.

As the fire ignites, it remains clear:
NOTHING BURNS LIKE A QUAD.



COVER: MT. VERNON E2 INSERT SHOWN IN PORCELAIN MAHOGANY WITH METAL SURROUND WITH CAST IRON TRIM IN PORCELAIN MAHOGANY

QUADRA-FIRE PELLET INSERTS

Introducing Quadra-Fire's pellet appliances, offering many styles, colors and technologies delivering:

PERFORMANCE

Get maximum heat and high efficiencies with one of three exclusive technologies offered by Quadra-Fire.

EASY OPERATION

Eliminate the hassle and save time with Quadra-Fire's fully automatic pellet appliances, simply fill the hopper, set your thermostat and walk away.

Enjoy quick and easy cleaning with Quadra-Fire's patented firepot design.



EXCLUSIVE TECHNOLOGIES

Innovative technology is at work in every Quadra-Fire. These advancements make it possible to burn pellets more effectively, efficiently, and with more control.

ADVANCED ENERGY



Advanced Energy (AE) delivers strong, economical heating performance with a 7-day programmable thermostat that constantly monitors

heat levels and automatically controls five heating levels. A patented auto-clean system providing hands-free cleaning and continuous burns with multiple fuels—wood pellets, grain, sunflower seeds.

EFFICIENT ENERGY



Efficient Energy (E2) technology helps achieve 87% efficiency—saving money by burning less fuel. Plus E2 automatically adjusts

the blower to maintain desired room temperature, and allows five manual heat output settings. Standard programmable wall thermostat allows you to run your appliance based on your personal comfort level all day or up to four different times each day.

ORIGINAL ENERGY



Original Energy (OE) delivers performance using an aluminum heat exchange system and three heat output settings.

The easy operation of a patented jam-free feed system and easy-clean firepot delivers a reliable heat source. Standard mechanical thermostat allows you to set your target room temperature and walk away.

FEATURES



CAST IRON AIRFOIL HEAT EXCHANGER

This cast iron airfoil heat exchanger is the most efficient way to transfer the heat from your appliance to your room.

- » MT. VERNON AE
- » MT. VERNON E2



ALUMINUM HEAT EXCHANGERS

Easy to clean by simply pulling on the cleaning rods when your appliance is cold.

- » CASTILE
- » CLASSIC BAY 1200
- » SANTA FE



CAST IRON FIREPOT

The most efficient way to burn pellets, creating temperatures exceeding 1000 degrees assuring the fuel is completely burned leaving only a fine ash behind.

- » MT. VERNON AE
- » MT. VERNON E2
- » CASTILE
- » CLASSIC BAY 1200
- » SANTA FE

MT. VERNON AE INSERT



Standard: 7-day Programmable Wall Thermostat



MT. VERNON AE INSERT SHOWN IN SIENNA BRONZE, WITH METAL SURROUND WITH CAST IRON TRIM IN SIENNA BRONZE AND OPTIONAL LOG SET

BTU/hr Input ¹ 16,800-53,300	Heating Capacity ² 1,300-2,900 sq ft	Efficiency ³ 76.9%	Burn Rate 1.9-6.2lb/hr	Emissions 1.7 g/hr	Hopper Capacity ¹ 52lb	Actual Weight 425lb
---	---	---	----------------------------------	------------------------------	---	-------------------------------



MT. VERNON AE INSERT

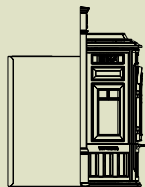

CLASSIC BLACK



SIENNA BRONZE



PORCELAIN MAHOGANY

MT. VERNON E2 INSERT



Standard: Programmable Wall Thermostat



MT. VERNON E2 INSERT SHOWN IN CLASSIC BLACK, WITH METAL SURROUND WITH CAST IRON TRIM IN CLASSIC BLACK AND OPTIONAL LOG SET

BTU/hr Input ¹ 18,100-55,000	Heating Capacity ² 1,300-2,900 sq ft	Efficiency ³ 81.6%	Burn Rate 2.1-6.4 lb/hr	Emissions .5 g/hr	Hopper Capacity ¹ 52lb	Actual Weight 425lb
---	---	---	-----------------------------------	-----------------------------	---	-------------------------------

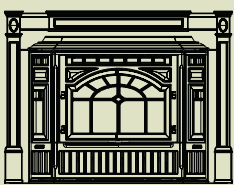

MT. VERNON E2 INSERT

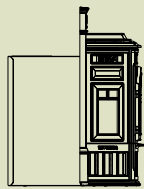

CLASSIC BLACK



SIENNA BRONZE



PORCELAIN MAHOGANY

CASTILE INSERT



Standard: Mechanical
Thermostat



CASTILE INSERT SHOWN IN CLASSIC BLACK, WITH METAL SURROUND
WITH CLASSIC BLACK CAST IRON TRIM AND OPTIONAL LOG SET

BTU/hr Output¹
**11,600-
38,700**

Heating Capacity²
**700-1,800
sq ft**

Efficiency⁴
78%

Burn Rate
**1.3-4.5
lb/hr**

Emissions
1.8 g/hr

Hopper Capacity¹
45lb

Actual Weight
260lb



CASTILE INSERT



CLASSIC
BLACK



SIENNA
BRONZE



PORCELAIN
MAHOGANY

CLASSIC BAY 1200 INSERT



Standard: Mechanical
Thermostat



CLASSIC BAY 1200 INSERT SHOWN WITH METAL SURROUND
WITH BLACK NICKEL TRIM AND OPTIONAL LOG SET

BTU/hr Output¹
**15,500-
46,400**

Heating Capacity²
**1,000-2,600
sq ft**

Efficiency⁴
78%

Burn Rate
**1.8-5.4
lb/hr**

Emissions
1.3 g/hr

Hopper Capacity¹
75lb

Actual Weight
243lb

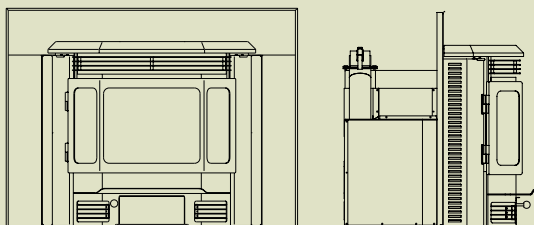

CLASSIC BAY 1200 INSERT

SANTA FE INSERT



Standard: Mechanical
Thermostat



SANTA FE INSERT SHOWN WITH METAL SURROUND
WITH BLACK NICKEL TRIM, AND OPTIONAL LOG SET

BTU/hr Output¹
11,600-38,700

Heating Capacity²
700-1,800
sq ft

Efficiency⁴
78%

Burn Rate
1.3-4.5
lb/hr

Emissions
1.8 g/hr

Hopper Capacity¹
45lb

Actual Weight
214lb

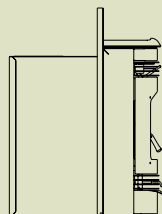
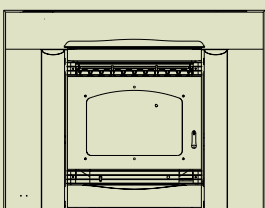

SANTA FE INSERT

PELLET INSERT COMPARISON

MT VERNON AE	MT VERNON E2	CASTILE	CLASSIC BAY 1200	SANTA FE
BTU/HOUR INPUT¹ » 16,800-53,300	BTU/HOUR INPUT¹ » 18,100-55,000	BTU/HOUR INPUT¹ » 11,600-38,700	BTU/HOUR INPUT¹ » 15,500-46,400	BTU/HOUR INPUT¹ » 11,600-38,700
HEATING CAPACITY² » 1,300 - 2,900 sq ft	HEATING CAPACITY² » 1,300 - 2,900 sq ft	HEATING CAPACITY² » 700 - 1,800 sq ft	HEATING CAPACITY² » 1,000 - 2,600 sq ft	HEATING CAPACITY² » 700 - 1,800 sq ft
EFFICIENCY³ » 76.9%	EFFICIENCY³ » 81.6%	EFFICIENCY⁴ » 78%	EFFICIENCY⁴ » 78%	EFFICIENCY⁴ » 78%
BURN RATE » 1.9-6.2lb/hr	BURN RATE » 2.1-6.4lb/hr	BURN RATE » 1.3-4.5lb/hr	BURN RATE » 1.8-5.4lb/hr	BURN RATE » 1.3-4.5lb/hr
EMISSIONS » 1.7 g/hr	EMISSIONS » .5 g/hr	EMISSIONS » 1.8 g/hr	EMISSIONS » 1.3 g/hr	EMISSIONS » 1.8 g/hr
HOPPER CAPACITY¹ » 52lb	HOPPER CAPACITY¹ » 52lb	HOPPER CAPACITY¹ » 45lb	HOPPER CAPACITY¹ » 75lb	HOPPER CAPACITY¹ » 45lb
ACTUAL WEIGHT » 425lb	ACTUAL WEIGHT » 425lb	ACTUAL WEIGHT » 260lb	ACTUAL WEIGHT » 243lb	ACTUAL WEIGHT » 214lb
TECHNOLOGIES » Advanced Energy (AE) Technology	TECHNOLOGIES » Efficient Energy (E2) Technology	TECHNOLOGIES » Original Energy (OE) Technology	TECHNOLOGIES » Original Energy (OE) Technology	TECHNOLOGIES » Original Energy (OE) Technology

4 EASY STEPS TO UPGRADE YOUR EXISTING WOOD-BURNING FIREPLACE

1. MEASURE YOUR EXISTING FIREPLACE
2. CHOOSE YOUR INSERT
3. SELECT A SURROUND
4. CUSTOMIZE YOUR INSERT

STEP 1 MEASURE YOUR EXISTING FIREPLACE

The height, width and depth of the existing fireplace opening is needed to ensure selection of an appropriately-sized insert:

- A. Fireplace front height _____ E. Hearth depth _____
 B. Fireplace front width _____ F. Hearth width _____
 C. Fireplace back width _____ G. Hearth to mantel height _____
 D. Fireplace Depth _____

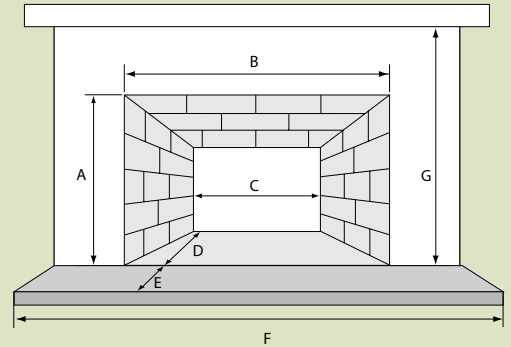

STEP 2 SELECT YOUR INSERT

Selecting an insert consists of two main factors. Keep these in mind and you're sure to make a solid choice:

- Consider the size of your existing fireplace opening- try and fill that space
- Consider how your insert will be used: room size, heating needs and usage frequency all come into play

STEP 3 CHOOSE YOUR SURROUND

Surrounds remove the gap between the fireplace insert and existing fireplace opening. Choose from numerous sizes and styles for a unique look.

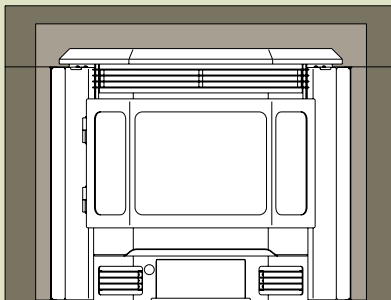

STANDARD SIZE SURROUND

LARGE SURROUND



CLASSIC BLACK METAL SURROUND WITH CAST IRON TRIM

TRIM COLORS



CLASSIC BLACK

SIENNA BRONZE

PORCELAIN MAHOGANY



CLASSIC BLACK METAL SURROUND WITH OUTSIDE TRIM

TRIM COLORS

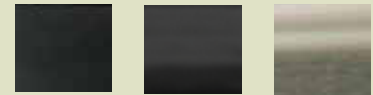

CLASSIC BLACK
»Castile

BLACK NICKEL
»Mt. Vernon AE
»Mt. Veron E2
»Classic Bay 1200
»Santa Fe

SATIN NICKEL
»Castile

SURROUND	MT. VERNON AE	MT. VERNON E2	CASTILE	CLASSIC BAY 1200i	SANTA FE
Metal Surround with Cast Iron Trim	Standard Size: 45"W x 34-1/2"H	Standard Size: 45"W x 34-1/2"H	Standard Size: 42-1/2"W x 30"H Large Size: 48"W x 34"H	n/a	n/a
Metal Surround with Outside trim	Large Size: 50"W x 33"H	Large Size: 50"W x 33"H	Standard Size: 43"W x 31"H Large Size: 51"W x 34"H	Standard Size: 40"W x 30"H Large Size: 50"W x 33"H	Standard Size: 40"W x 30"H Large Size: 50"W x 33"H

STEP 4 CUSTOMIZE YOUR INSERT

PROGRAMMABLE WALL THERMOSTAT

Allows you to run your appliance based on your personal comfort level all day or up to four different times each day.



- » CASTILE
- » CLASSIC BAY 1200
- » SANTA FE

REMOTE CONTROL

Allows you to run your appliance based on your personal comfort level.



- » MT. VERNON E2
- » CASTILE
- » CLASSIC BAY 1200
- » SANTA FE

LOG SET



- » MT. VERNON AE
- » MT. VERNON E2
- » CASTILE
- » CLASSIC BAY 1200
- » SANTA FE

CLEARANCES

CLEARANCES							Clearance Diagram
Insert	A	B	C	D	E	F	
MT. VERNON AE	6"	41"*	0"	0"	6"	6"	
MT. VERNON E2	6"	41"*	0"	0"	6"	6"	
CASTILE	16"	37"	4-3/4"	10"	6"	6"	
CLASSIC BAY 1200	6"	37-1/2"	3"	6"	8"	n/a	
SANTA FE	16"	37-3/8"	4-3/4"	10"	6"	6"	

* If mantel depth is 10" or less then B = 39"

MASONRY AND FACTORY BUILT ZERO CLEARANCE							Clearance Diagram
Insert	A		B	C	D		
MT. VERNON AE	23-7/8"		34"	24"	15"		
MT. VERNON E2	23-7/8"		34"	24"	16-1/2"		
CASTILE	21-1/4"		28-1/8"	23-5/8"	17"		
CLASSIC BAY 1200	masonry	rear vent n/a	top vent 19-1/2"	29-1/2"	22"		13"
	ZC	rear vent 22-1/2"	top vent 25-1/2"	29-1/2"	29-1/4"		15-1/2"
SANTA FE	23-1/4"		29-1/4"	24"	16"		

IMPORTANT - READ BEFORE YOU INSTALL

Refer to the Owner/Installation Manual for complete clearance requirements and specifications. The images and descriptions on this brochure are provided to assist you in product selection only.





Thank you from everyone at Quadra-Fire



QUADRA-FIRE®

NOTHING BURNS LIKE A QUAD

www.quadrafire.com | 800-926-4356

 facebook.com/QuadraFire  twitter.com/QuadraFire  youtube.com/QuadraFirePower

Available From:

Limited Lifetime Warranty⁵

The strongest in the industry, Quadra-Fire provides a limited lifetime warranty on the most important aspects: firebox and heat exchanger.

1 BTU/hour input based on the maximum feed rate per hour multiplied by approximately 8600 BTUs which is the average BTUs from a pound of pellets. Fuel density and pellet shape will affect hopper capacity. 2 See your local Quadra-Fire dealer for help in determining the product that best suits your heating needs based on climate and home efficiency. 3 Weighted average LHV (Low Heating Value) efficiency. 4 EPA default efficiency. 5 For full warranty details go to www.quadrafire.com.

IMPORTANT - READ BEFORE YOU INSTALL!

Refer to the Owner/Installation Manual for complete clearance requirements and specifications. Power cords for the fans will run along the hearth and can be directed to either side of the appliance for flexible installation. The images and descriptions in this brochure are provided to assist you in product selection only.

Quadra-Fire is a registered trademark of Hearth & Home Technologies. Product specifications and pricing subject to change without notice.

Fireplace, stove and insert surfaces get extremely HOT and can cause severe burns if touched. Keep a safe distance away. To learn more visit www.quadrafire.com/fireplacesafety.

QDF-1015U-0416