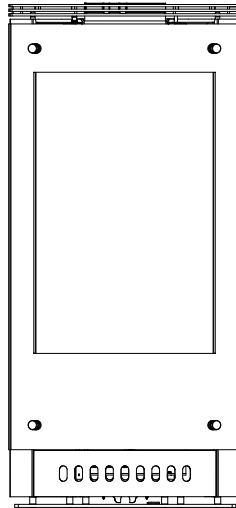


#### Model(s):

PALOMA-BZ-MOD

PALOMA-GY-MOD

PALOMA-BK-MOD



### CAUTION



#### DO NOT DISCARD THIS MANUAL

- Important operating and maintenance instructions included.
- Read, understand and follow these instructions for safe installation and operation.
- Leave this manual with party responsible for use and operation.

**⚠ WARNING:** If the information in these instructions is not followed exactly, a fire or explosion may result causing property damage, personal injury, or death.

- Do not store or use gasoline or other flammable vapors and liquids in the vicinity of this or any other appliance.
- **What to do if you smell gas**
  - Do not try to light any appliance.
  - Do not touch any electrical switch. Do not use any phone in your building.
  - Immediately call your gas supplier from a neighbor's phone. Follow the gas supplier's instructions.
  - If you cannot reach your gas supplier, call the fire department.
- Installation and service must be performed by a qualified installer, service agency, or the gas supplier.

This appliance may be installed as an OEM installation in manufactured home (USA only) or mobile home and must be installed in accordance with the manufacturer's instructions and the manufactured home construction and safety standard, *Title 24 CFR, Part 3280 or Standard for Installation in Mobile Homes, CAN/CSA Z240MH.*

*This appliance is only for use with the type(s) of gas indicated on the rating plate.*

### ⚠ WARNING



#### HOT SURFACES!

Glass and other surfaces are hot during operation AND cool down.

#### Hot glass will cause burns.

- Do not touch glass until it is cooled
  - NEVER allow children to touch glass
  - Keep children away
  - CAREFULLY SUPERVISE children in same room as fireplace.
  - Alert children and adults to hazards of high temperatures.
- High temperatures may ignite clothing or other flammable materials.**
- Keep clothing, furniture, draperies and other flammable materials away.

In the Commonwealth of Massachusetts:

- Installation must be performed by a licensed plumber or gas fitter;

See Table of Contents for location of additional Commonwealth of Massachusetts requirements.



Installation and service of this appliance should be performed by qualified personnel. Hearth & Home Technologies suggests NFI certified or factory trained professionals, or technicians supervised by an NFI certified professional.

Read this manual before installing or operating this appliance.

Please retain this owner's manual for future reference.

## Congratulations

Congratulations on selecting a Heat & Glo gas appliance an elegant and clean alternative to wood burning appliances. The Heat & Glo gas appliance you have selected is designed to provide the utmost in safety, reliability, and efficiency.

As the owner of a new appliance, you'll want to read and carefully follow all of the instructions contained in this *Owner's Manual*. Pay special attention to all Cautions and Warnings.

This *Owner's Manual* should be retained for future reference. We suggest that you keep it with your other important documents and product manuals.

The information contained in this *Owner's Manual*, unless noted otherwise, applies to all models and gas control systems.

Your new Heat & Glo gas appliance will give you years of durable use and trouble-free enjoyment. Welcome to the Heat & Glo family of appliance products!

### Homeowner Reference Information

*We recommend that you record the following pertinent information about your appliance.*

Model Name: \_\_\_\_\_ Date purchased/installed: \_\_\_\_\_

Serial Number: \_\_\_\_\_ Location on appliance: \_\_\_\_\_

Dealership purchased from: \_\_\_\_\_ Dealer Phone: \_\_\_\_\_


Notes: \_\_\_\_\_

### Listing Label Information/Location

The model information regarding your specific appliance can be found on the rating plate usually located in the control area of the appliance.

Type of Gas

Gas and Electric Information

<b>HEAT &amp; GLO</b> No one builds a better fire		Heat & Glo, a brand of Hearth & Home Technologies 7571 215th Street West, Lakeville, MN 55044		<b>GAS-FIRED</b> 	
Not for use with solid fuel. ( <i>Ne doit pas entre utilise avec un combustible solide</i> ).					
Type of Gas ( <i>Sorte De Gaz</i> ):		This appliance must be installed in accordance with local codes, if any; if not, follow ANSI Z223.1 in the USA or CAN/CGA B149 installation codes. ( <i>Installer l'appareil selon les codes ou reglements locaux ou, en l'absence de tels reglements, selon les codes d'installation CAN/CGA-B149.</i> )			
<b>NATURAL GAS</b>		<b>ANSI Z21XX-XXXX · CSA 2.XX-MXX</b>			
Minimum Permissible Gas Supply for Purposes of Input Adjustment.					
Approved Minimum ( <i>De Gaz</i> ) Acceptable		0.0 in w.c. ( <i>Po. Col. d'eau</i> )			
Maximum Pressure ( <i>Pression</i> )		0.0 in w.c. ( <i>Po. Col. d'eau</i> )			
Maximum Manifold Pressure ( <i>Pression</i> )		0.0 in w.c. ( <i>Po. Col. d'eau</i> )			
Minimum Manifold Pressure ( <i>Pression</i> )		0.0 in w.c. ( <i>Po. Col. d'eau</i> )			
Total Electrical Requirements: 000Vac, 00Hz., less than 00 Amperes				<b>MADE IN USA</b>	
ALTITUDE:		0-0000 FT.		IN CANADA	
MAX. INPUT BTUH:		00,000		0000-0000FT.	
MIN. INPUT BTUH:		00,000		00,000	
ORIFICE SIZE:		#XXXXX		#XXXXX	
Model: ( <i>Modele</i> ):		XXXXXXXXXX			
Serial ( <i>Serie</i> ):		XXXXXXXXXX			

Model Number

Serial Number

# Table of Contents

## 1 Listing and Code Approvals

A. Appliance Certification	4
B. Glass Specifications	4
C. BTU Specifications	4
D. High Altitude Installations	4
E. Non-Combustible Materials Specification	4
F. Combustible Materials Specification	4
G. Electrical Codes	4
H. Requirements for the Commonwealth of Massachusetts	5

## 2 Getting Started

A. Design and Installation Considerations	6
B. Tools and Supplies Needed	6
C. Inspect Appliance and Components	6

## 3 Framing and Clearances

A. Selecting Appliance Location	7
B. Clearances to Combustibles	8

## 4 Termination Locations

A. Vent Termination Minimum Clearances	9
--	---

## 5 Vent Information

A. Venting Components	11
B. Use of Elbows	11
C. Measuring Standards	11
D. How to Use the Vent Graph	12
E. Venting Guidelines	12
F. Horizontal Termination	13
G. Vertical Termination	16
H. Secure the Vent Sections	18
I. Disassemble Vent Sections	19
J. Cathedral Ceiling	19
K. Class A Metal Chimney	20
L. Existing Masonry Chimney	21
M. Slim Line Wall Thimble	24

## 6 Gas Information

A. Fuel Conversion	26
B. Gas Pressures	26
C. Gas Connection	27

## 7 Electrical Information

A. Recommendation for Wire	28
B. Connecting to the Appliance	28
C. IntelliFire® Ignition System Wiring	28
D. Loss of Power and Battery Backup Usage	29
E. Wall Switch Installation for Fan (Optional)	30

## 8 Appliance Setup

A. Remove Shipping Materials	31
B. Unbolting Appliance from the Pallet	31
C. Leveling and Lagging Down the Appliance	32
D. Accessories	32
E. Top to Rear Vent Conversion	33
F. Shutter Adjustment	34
G. Installing the Vent Restrictor	34
H. Installing Rock Media and Ember Material	35
I. Optional Blower	37
J. Remote Controls	40
K. Front Door Glass Assembly Replacement	42
L. Inner Glass Door Assembly Replacement	42

## 9 Operating Instructions

A. Before Lighting Appliance	43
B. Controls	43
C. Lighting Instructions (IPI)	44
D. After Appliance is Lit	45
E. Frequently Asked Questions	45

## 10 Troubleshooting

A. IntelliFire Ignition System	46
--------------------------------	----

## 11 Maintaining and Servicing Appliance

A. Maintenance Tasks	48
----------------------	----

## 12 Reference Materials

A. Appliance Dimension Diagram	50
→ B. Vent Components Diagram	51
C. Vent Components List	53
D. Service Parts	54
E. Limited Lifetime Warranty	58
F. Contact Information	60

→ = Contains updated information.

# 1 Listing and Code Approvals

## A. Appliance Certification

**MODELS:** PALOMA-BZ-MOD, PALOMA-BK-MOD, ALOMA-GY-MOD

**LABORATORY:** Underwriters Laboratories, Inc. (UL)

**TYPE:** Vented Gas Fireplace Heater

**STANDARD:** ANSI Z21.88b-2008 • CSA 2.33a-2008

This product is listed to ANSI standards for “Vented Gas Appliance Heaters” and applicable sections of “Gas Burning Heating Appliances for Manufactured Homes and Recreational Vehicles”, and “Gas Fired Appliances for Use at High Altitudes”.

### NOT INTENDED FOR USE AS A PRIMARY HEAT SOURCE.

This appliance is tested and approved as either supplemental room heat or as a decorative appliance. It should not be factored as primary heat in residential heating calculations.

Manufactured Home or Mobile Home installation may occur only after the home is site located and must conform with the Manufactured Home Construction and Safety Standard, Title 24 CFR, Part 3280, or, when such a standard is not applicable, the Standard for Manufactured Home Installations, ANSI/NCSCBS A225.1, or Standard for Gas Equipped Recreational Vehicles and Mobile Housing, CSA Z240.4.

When installed, the appliance must be electrically grounded in accordance with local codes or, in the absence of local codes, with the National Electrical Code, ANSI/NFPA 70, or the Canadian Electrical Code, CSA C22.1.

## B. Glass Specifications

This appliance is equipped with 5 mm ceramic glass behind the curved glass. Replace glass only with 5 mm ceramic glass. Please contact your dealer for replacement glass.

**Note:** This installation must conform with local codes. In the absence of local codes you must comply with the National Fuel Gas Code, ANSI Z223.1-latest edition in the U.S.A. and the CAN/CGA B149 Installation Codes in Canada.

## C. BTU Specifications

Model (US or Canada)	Maximum Input BTU/h	Minimum Input BTU/h	Orifice Size (DMS)	*Steady State Efficiency %	**P.4 %
Paloma (NG)	28,000	20,000	38	81	71
Paloma (LP)	26,000	19,000	53	81	72

\*Maximum Vent Blower On

\*\*Canada Only

## D. High Altitude Installations

Omni-Test Laboratories, Inc. listed gas appliances are tested and approved without requiring changes for elevations from 0 to 2000 feet in the U.S.A. and 0 to 4500 feet in Canada.

When installing this appliance at an elevation above 2000 feet, it may be necessary to decrease the input rating by changing the existing burner orifice to a smaller size. Input rate should be reduced by 4% for each 1000 feet above a 2000 foot elevation in the U.S.A. If the heating value of the gas has been reduced, these rules do not apply. To identify the proper orifice size, check with the local gas utility.

If installing this appliance at an elevation above 4500 feet (in Canada), check with local authorities.

**WARNING! Risk of Fire, Explosion or Electric Shock! DO NOT use this appliance if any part has been under water. Call a qualified service technician to inspect the appliance and to replace any part of the control system and/or gas control which has been under water.**

## E. Non-Combustible Materials Specification

Material which will not ignite and burn. Such materials are those consisting entirely of steel, iron, brick, tile, concrete, slate, glass or plasters, or any combination thereof.

Materials that are reported as passing **ASTM E 136, Standard Test Method for Behavior of Materials in a Vertical Tube Furnace at 750°C**, shall be considered non-combustible materials.

## F. Combustible Materials Specification

Materials made of or surfaced with wood, compressed paper, plant fibers, plastics, or other material that can ignite and burn, whether flame proofed or not, or whether plastered or unplastered shall be considered combustible materials.

## G. Electrical Codes

**NOTICE:** This appliance must be electrically wired and grounded in accordance with local codes or, in the absence of local codes, with **National Electric Code ANSI/NFPA 70-latest edition or the Canadian Electric Code CSA C22.1.**

- A 110-120 VAC circuit for this product must be protected with ground-fault circuit-interrupter protection, in compliance with the applicable electrical codes, when it is installed in locations such as in bathrooms or near sinks.

Note: The following requirements reference various Massachusetts and national codes not contained in this document.

## H. Requirements for the Commonwealth of Massachusetts

For all side wall horizontally vented gas fueled equipment installed in every dwelling, building or structure used in whole or in part for residential purposes, including those owned or operated by the Commonwealth and where the side wall exhaust vent termination is less than seven (7) feet above finished grade in the area of the venting, including but not limited to decks and porches, the following requirements shall be satisfied:

### Installation of Carbon Monoxide Detectors

At the time of installation of the side wall horizontal vented gas fueled equipment, the installing plumber or gas fitter shall observe that a hard wired carbon monoxide detector with an alarm and battery back-up is installed on the floor level where the gas equipment is to be installed. In addition, the installing plumber or gas fitter shall observe that a battery operated or hard wired carbon monoxide detector with an alarm is installed on each additional level of the dwelling, building or structure served by the side wall horizontal vented gas fueled equipment. It shall be the responsibility of the property owner to secure the services of qualified licensed professionals for the installation of hard wired carbon monoxide detectors.

In the event that the side wall horizontally vented gas fueled equipment is installed in a crawl space or an attic, the hard wired carbon monoxide detector with alarm and battery back-up may be installed on the next adjacent floor level.

In the event that the requirements of this subdivision can not be met at the time of completion of installation, the owner shall have a period of thirty (30) days to comply with the above requirements; provided, however, that during said thirty (30) day period, a battery operated carbon monoxide detector with an alarm shall be installed.

### Approved Carbon Monoxide Detectors

Each carbon monoxide detector as required in accordance with the above provisions shall comply with NFPA 720 and be ANSI/UL 2034 listed and IAS certified.

### Signage

A metal or plastic identification plate shall be permanently mounted to the exterior of the building at a minimum height of eight (8) feet above grade directly in line with the exhaust vent terminal for the horizontally vented gas fueled heating appliance or equipment. The sign shall read, in print size no less than one-half (1/2) inch in size, **“GAS VENT DIRECTLY BELOW. KEEP CLEAR OF ALL OBSTRUCTIONS”**.

## Inspection

The state or local gas inspector of the side wall horizontally vented gas fueled equipment shall not approve the installation unless, upon inspection, the inspector observes carbon monoxide detectors and signage installed in accordance with the provisions of 248 CMR 5.08(2)(a)1 through 4.

## Exemptions

The following equipment is exempt from 248 CMR 5.08(2)(a)1 through 4:

- The equipment listed in Chapter 10 entitled “Equipment Not Required To Be Vented” in the most current edition of NFPA 54 as adopted by the Board; and
- Product Approved side wall horizontally vented gas fueled equipment installed in a room or structure separate from the dwelling, building or structure used in whole or in part for residential purposes.

## MANUFACTURER REQUIREMENTS

### Gas Equipment Venting System Provided

When the manufacturer of Product Approved side wall horizontally vented gas equipment provides a venting system design or venting system components with the equipment, the instructions provided by the manufacturer for installation of the equipment and the venting system shall include:

- Detailed instructions for the installation of the venting system design or the venting system components; and
- A complete parts list for the venting system design or venting system.

### Gas Equipment Venting System NOT Provided

When the manufacturer of a Product Approved side wall horizontally vented gas fueled equipment does not provide the parts for venting the flue gases, but identifies “special venting systems”, the following requirements shall be satisfied by the manufacturer:

- The referenced “special venting system” instructions shall be included with the appliance or equipment installation instructions; and
- The “special venting systems” shall be Product Approved by the Board, and the instructions for that system shall include a parts list and detailed installation instructions.

A copy of all installation instructions for all Product Approved side wall horizontally vented gas fueled equipment, all venting instructions, all parts lists for venting instructions, and/or all venting design instructions shall remain with the appliance or equipment at the completion of the installation.

**See Gas Connection section for additional Commonwealth of Massachusetts requirements.**

# 2 Getting Started

## A. Design and Installation Considerations

Heat & Glo direct vent gas appliances are designed to operate with all combustion air siphoned from outside of the building and all exhaust gases expelled to the outside. No additional outside air source is required.



### CAUTION

Check building codes prior to installation.

- Installation **MUST** comply with local, regional, state and national codes and regulations.
- Consult local building, fire officials or authorities having jurisdiction about restrictions, installation inspection, and permits.

When planning an appliance installation, it's necessary to determine the following information before installing:

- Where the appliance is to be installed.
- The vent system configuration to be used.
- Gas supply piping.
- Electrical wiring.
- Framing and finishing details.
- Whether optional accessories—devices such as a fan, wall switch, or remote control—are desired.



### WARNING



Keep appliance dry.

- Mold or rust may cause odors.
- Water may damage controls.



## B. Tools and Supplies Needed

Before beginning the installation be sure that the following tools and building supplies are available.

- |                        |  |
|------------------------|--|
| Reciprocating saw      | Framing material   |
| Pliers                 | Noncorrosive leak check solution or combustible gas detector |
| Hammer                 | Gloves   |
| Phillips screwdriver   | Framing square   |
| Flat blade screwdriver | Electric drill and bits (1/4 in.)                            |
| Plumb line             | Safety glasses   |
| Level                  | Wrenches   |
| Ratchets/Sockets       | Allen Wrench Set   |
| Manometer              | Voltmeter  |
| Tape measure           | 1/2 - 3/4 inch length, #6 or #8 Self-drilling screws         |

One 1/4 inch female connection (for optional fan)

Caulk with a minimum of 300°F continuous exposure rating

## C. Inspect Appliance and Components

- Carefully remove the appliance and components from the packaging.
- The vent system components and decorative doors and fronts may be shipped in separate packages.
- If packaged separately, the rock set must be installed.
- Report to your dealer any parts damaged in shipment, particularly the condition of the glass.
- **Read all of the instructions before starting the installation. Follow these instructions carefully during the installation to ensure maximum safety and benefit.**

**WARNING! Risk of Fire or Explosion! Damaged parts could impair safe operation. DO NOT install damaged, incomplete or substitute components. Keep appliance dry.**

Hearth & Home Technologies disclaims any responsibility for, and the warranty will be voided by, the following actions:

- Installation and use of any damaged appliance or vent system component.
- Modification of the appliance or vent system.
- Installation other than as instructed by Hearth & Home Technologies.
- Improper positioning of the rock set or the glass door.
- Installation and/or use of any component part not approved by Hearth & Home Technologies.

**Any such action may cause a fire hazard.**

# 3 Framing and Clearances

**Note:**

- Illustrations reflect typical installations and are FOR DESIGN PURPOSES ONLY.
- Illustrations/diagrams are not drawn to scale.
- Actual installation may vary due to individual design preference.

## A. Selecting Appliance Location

When selecting a location for your appliance it is important to consider the required clearances to walls (see figure 3.1).

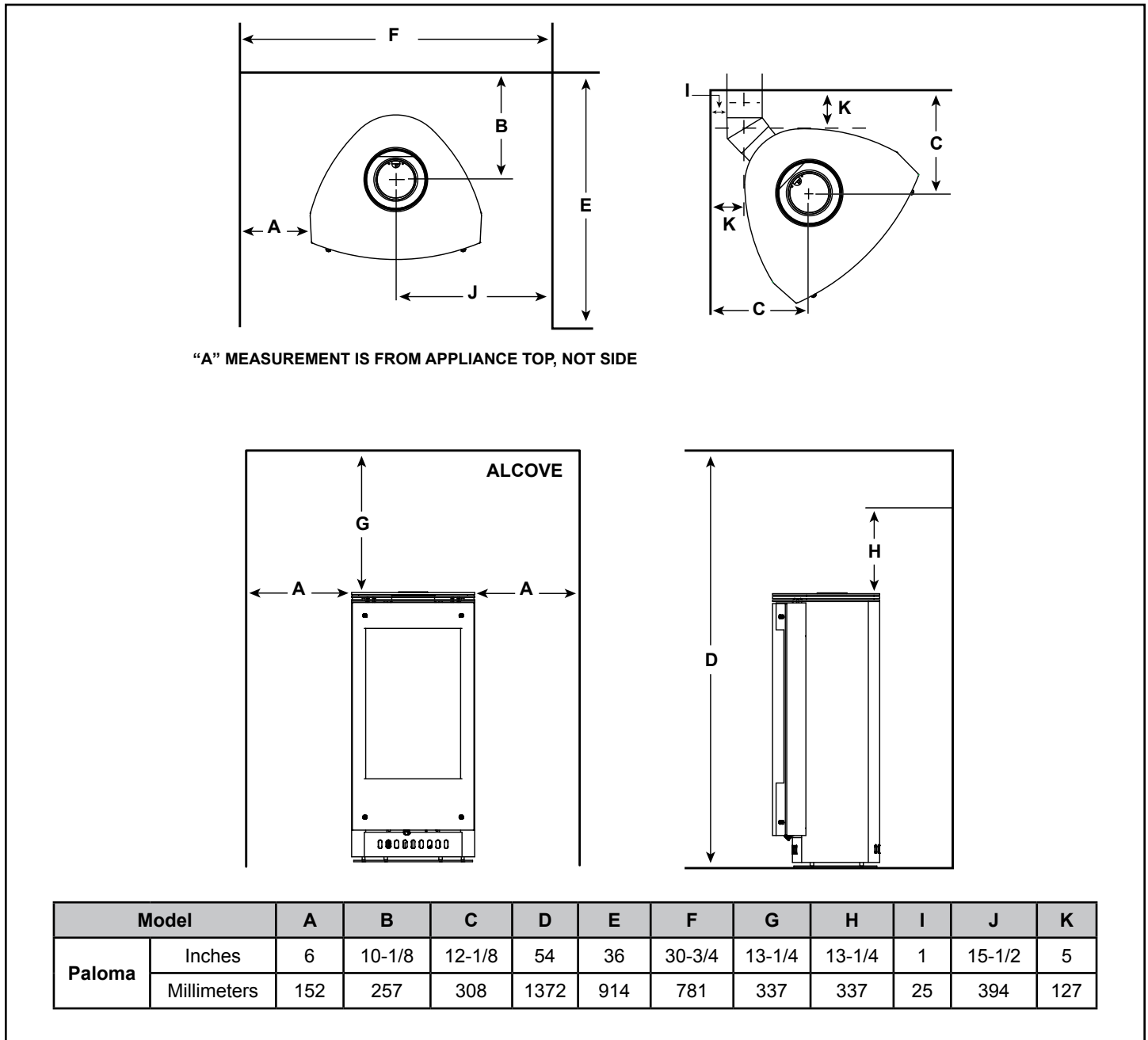


Figure 3.1

## B. Clearances to Combustibles

**WARNING! Risk of Fire or Burns!** Provide adequate clearance around air openings and for service access. **Due to high temperatures, the appliance should be located out of traffic and away from furniture and draperies.**

**NOTE:** For actual appliance dimensions refer to Section 12.

It is permissible to place the appliance on carpet.



### CAUTION

Some carpet materials may be sensitive to radiant heat from the appliance causing discoloration or odor.

**Note:** Flooring beneath appliance may reach 90 degrees plus room ambient temperature. Check with flooring manufacturer for maximum temperature allowed on flooring surfaces.



### WARNING



Fire Risk.

- Locate and install appliance to all clearance specifications in manual.



### WARNING



Fire Risk.

Odor Risk.

Tipping Risk


- Install gas stove on a stable, level platform/floor strong enough to support gas stove without tipping.
- USE wood flooring, ceramic tile, brick hearth or high pressure laminate flooring applied directly over the sub-flooring material.






# 4 Termination Locations

## A. Vent Termination Minimum Clearances


**WARNING**



**Fire Risk.**

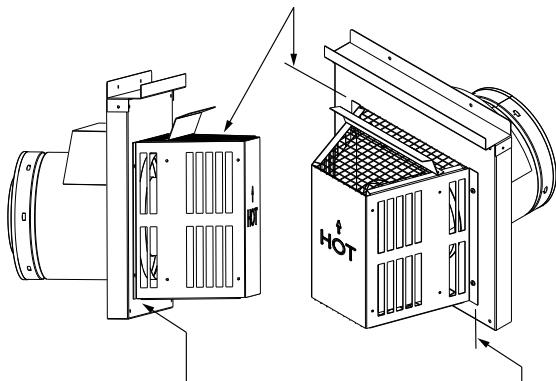
**Explosion Risk.**

Maintain vent clearance to combustibles as specified.

- Do not pack air space with insulation or other materials.

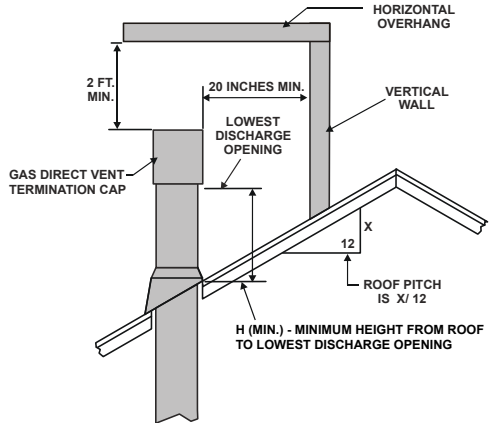
Failure to keep insulation or other materials away from vent pipe may cause fire.

Measure vertical clearances from this surface.



Measure horizontal clearances from this surface.  
(See Figure 4.4 for specific clearances)

**Figure 4.1**



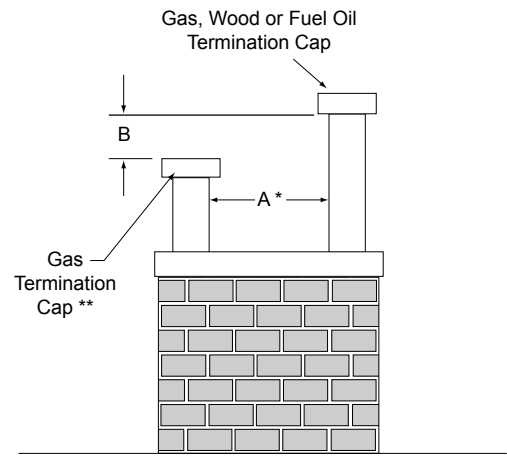
Roof Pitch	H (Min.) Ft.
Flat to 6/12.....	1.0*
Over 6/12 to 7/12.....	1.25*
Over 7/12 to 8/12.....	1.5*
Over 8/12 to 9/12.....	2.0*
Over 9/12 to 10/12.....	2.5*
Over 10/12 to 11/12.....	3.25
Over 11/12 to 12/12.....	4.0
Over 12/12 to 14/12.....	5.0
Over 14/12 to 16/12.....	6.0
Over 16/12 to 18/12.....	7.0
Over 18/12 to 20/12.....	7.5
Over 20/12 to 21/12.....	8.0

\* 3 foot minimum in snow regions

**Figure 4.2 Minimum height from roof to lowest discharge opening**

Figure 4.2 specifies minimum vent heights for various pitched roofs.

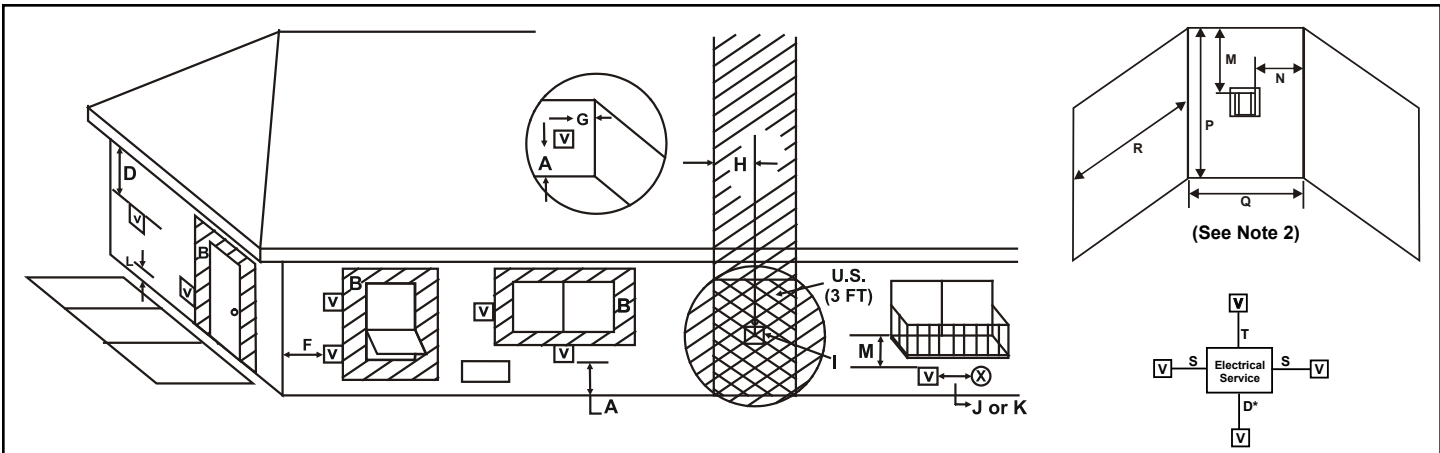
A	B
6 in. (minimum) up to 20 in. <i>152 mm/508 mm</i>	18 in. minimum <i>457 mm</i>
20 in. and over	0 in. minimum



\* If using decorative cap cover(s), this distance may need to be increased. Refer to the installation instructions supplied with the decorative cap cover.

\*\* In a staggered installation with both gas and wood or fuel oil terminations, the wood or fuel oil termination cap must be higher than the gas termination cap.

**Figure 4.3 Staggered Termination Caps**



**V** = VENT TERMINAL      **X** = AIR SUPPLY INLET      **▨** = AREA WHERE TERMINAL IS NOT PERMITTED

- A = 12 inches.....clearances above grade, veranda, porch, deck or balcony  
(See Note 1)
- B = 12 inches.....clearances to window or door that may be opened, or to permanently closed window. (Glass)
- D\* = 18 inches.....vertical clearance to unventilated soffit or to ventilated soffit located above the terminal  
\*30 inches.....for vinyl clad soffits and below electrical service
- F = 9 inches.....clearance to outside corner
- G = 6 inches.....clearance to inside corner
- H = 3 ft. (Canada).....not to be installed above a gas meter/regulator assembly within 3 feet (90 cm) horizontally from the center-line of the regulator
- I = 3 ft.....clearance to gas service regulator vent outlet
- J = 9 inches (U.S.A.)  
12 inches (Canada) clearance to non-mechanical air supply inlet to building or the combustion air inlet to any other appliance
- K = 3 ft. (U.S.A.)  
6 ft. (Canada).....clearance to a mechanical (powered) air supply inlet

- L\*\* = 7 ft.....clearance above paved sidewalk or a paved driveway located on **public** property  
(See Note 1)
- M\*\*\* = 18 inches.....clearance under veranda, porch, deck, balcony or overhang  
42 inches ..... vinyl
- S = 6 inches.....clearance from sides of electrical service  
(See Note 5)
- T = 12 inches.....clearance above electrical service  
(See Note 5)

**Alcove Applications**

- N = 6 inches .....non-vinyl sidewalls  
12 inches .....vinyl sidewalls
- P = 8 ft.

	<b>Q<sub>MIN</sub></b>	<b>R<sub>MAX</sub></b>
1 cap	3 feet	2 x Q <sub>ACTUAL</sub>
2 caps	6 feet	1 x Q <sub>ACTUAL</sub>
3 caps	9 feet	2/3 x Q <sub>ACTUAL</sub>
4 caps	12 feet	1/2 x Q <sub>ACTUAL</sub>
<b>Q<sub>MIN</sub> = # termination caps x 3 R<sub>MAX</sub> = (2 / # termination caps) x Q<sub>ACTUAL</sub></b>		

\*\* a vent shall not terminate directly above a sidewalk or paved driveway which is located between two single family dwellings and serves both dwellings.  
\*\*\* only permitted if veranda, porch, deck or balcony is fully open on a minimum of 2 sides beneath the floor, or meets Note 2.

**NOTE 1:** On private property where termination is less than 7 feet above a sidewalk, driveway, deck, porch, veranda or balcony, use of a listed cap shield is suggested. (See vents components page)

**NOTE 2:** Termination in an alcove space (spaces open only on one side and with an overhang) are permitted with the dimensions specified for vinyl or non-vinyl siding and soffits. **1.** There must be 3 feet minimum between termination caps. **2.** All mechanical air intakes within 10 feet of a termination cap must be a minimum of 3 feet below the termination cap. **3.** All gravity air intakes within 3 feet of a termination cap must be a minimum of 1 foot below the termination cap.

**NOTE 3:** Local codes or regulations may require different clearances.  
**NOTE 4:** Termination caps may be hot. Consider their proximity to doors or other traffic areas.  
**NOTE 5:** Location of the vent termination must not interfere with access to the electrical service.

**WARNING: In the U.S:** Vent system termination is **NOT** permitted in screened porches. You must follow side wall, overhang and ground clearances as stated in the instructions.

**In Canada:** Vent system termination is **NOT** permitted in screened porches. Vent system termination is permitted in porch areas with two or more sides open. You must follow all side walls, overhang and ground clearances as stated in the instructions.

Heat & Glo assumes no responsibility for the improper performance of the appliance when the venting system does not meet these requirements.

**Figure 4.4 Minimum Clearances for Termination**

**CAUTION: IF EXTERIOR WALLS ARE FINISHED WITH VINYL SIDING, IT IS SUGGESTED THAT A VINYL PROTECTOR KIT BE INSTALLED.**

# 5 Vent Information

## A. Venting Components




In order to comply with applicable codes and product warranties, use only Hearth & Home Technologies (HHT) venting components.

**DO NOT USE FIELD-FABRICATED VENTING COMPONENTS.** Refer to the venting manufacturer's instructions.


This product is approved to be vented either horizontally, through the side wall or vertically through the roof. You may vent through a Class A or masonry chimney if an approved adapter is used.

This appliance is a direct vent heater. All combustion air must come directly from the outside of the building. The vent pipe for this unit consists of an inner and an outer pipe. The inner pipe carries the appliance exhaust out of the system, and the outer pipe brings fresh combustion air into the appliance.

- A round support box/wall thimble or heat shield is required when the venting passes through a combustible wall.
- A support box or ceiling firestop is required when the venting passes through a ceiling.
- Roof flashing and a storm collar are required when venting passes through the roof.
- Follow instructions provided with the venting for installation of these items.

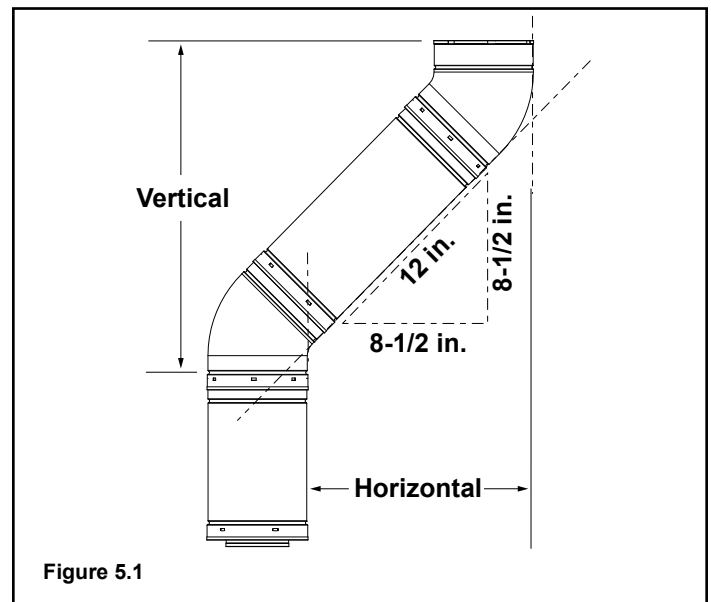
 <b>WARNING</b>	
	<b>Fire Hazard.</b>
	<b>Explosion Risk.</b>
	<b>Asphyxiation Risk.</b>
	Do NOT connect this gas appliance to a chimney flue serving a separate solid-fuel or gas burning appliance.
	<ul style="list-style-type: none"><li>• Vent this appliance directly outside.</li><li>• Use separate vent system for this appliance.</li></ul>
	May impair safe operation of this appliance or other appliances connected to the flue.

## B. Use of Elbows

 <b>CAUTION</b>	
ALL vent configuration specifications MUST be followed.	
<ul style="list-style-type: none"><li>• This product is tested and listed to these specifications.</li><li>• Appliance performance will suffer if specifications are not followed.</li></ul>	

Diagonal runs have both vertical and horizontal vent aspects when calculating the effects. Use the rise for the vertical aspect and the run for the horizontal aspect (see Figure 5.1).

Two 45° elbows may be used in place of one 90° elbow. On 45° runs, one foot of diagonal is equal to 8-1/2 (216 mm) inches horizontal run and 8-1/2 (216 mm) inches vertical run. A length of straight pipe is allowed between two 45° elbows (see Figure 5.1).



## C. Measuring Standards

Vertical and horizontal measurements were made using the following standards.

1. Pipe measurements are from center line to center line.
2. Horizontal terminations are measured to the outside mounting surface (flange of termination cap) (see Figure 4.1) on page 9.
3. Vertical terminations are measured to the top of the last pipe before termination cap.
4. Horizontal pipe installed level with 1/4 inch rise per foot.

## D. How to Use the Vent Graph

1. Measure the distance from the top of appliance to the center of the 90° elbow. On the graph below, draw a horizontal line from that measurement on the vertical axis across until it intersects with the slanted line.
2. From the point of this intersection, draw a vertical line to the bottom of the graph.
3. The point at which this line meets the bottom line of the graph is the maximum length of the horizontal run.

**Example 1:** If the vertical dimension from the top of the appliance to the center of the 90° elbow is 7 ft. (2 m), the horizontal run to the outer wall flange must not exceed 13 ft. (4 m).

**Example 2:** If the vertical dimension from the top of the appliance is 21 ft. (6.4 m), the horizontal run to the outer wall flange must not exceed 9 ft. (3 m).

4. Each 90° elbow is equivalent to 3 ft. (914 mm) of vent pipe and each 45° elbow is equivalent to 1 ft. (305 mm) of vent pipe, and must be subtracted from vent pipe run. A single vertical to horizontal 90° elbow is already calculated into the allowable 15 ft. (5 m) run. Each additional 90° elbow reduces the maximum horizontal distance by 3 ft. (914 mm).

**Example:** The use of three elbows would reduce the allowable horizontal run to 9 ft. (3 - 1 = 2 elbows x 3 ft. = 6 ft.; 15 ft. max. - 6 ft. = 9 ft. max.)

## E. Venting Guidelines

- The maximum horizontal vent run is 15 ft. (5 m) when the vertical vent rise is 10 ft. (3 m).
- The minimum horizontal vent run is 11-5/8 in. (295 mm).
- Horizontal sections require a 1/4 in. (6 mm) rise for every 12 in. (305 mm) of horizontal travel.
- Horizontal sections require noncombustible support every 3 ft. (914 mm), e.g. wall strap.
- Wall thickness: Minimum 4 in. (102 mm). Maximum 20 in. (508 mm).
- Vent Diameter: Exterior 6-5/8 in. (168 mm); Inner 4 in. (102 mm).

### EXCEPTION FOR REAR VENT KIT, HORIZONTAL INSTALLATION:

- The maximum horizontal vent run is 2 ft. (610 mm).

**NOTICE: Maximum horizontal vent run is 18 in. (457 mm) when using the HRC termination cap.**

- The maximum horizontal vent run with a 45° elbow is 18 in. (457 mm).
- No external minimum rise is required. The minimum horizontal vent run is 11-5/8 in. (295 mm).
- For any vertical rise when rear venting, a minimum of 2 ft. (610 mm) vertical must be used prior to any horizontal run.

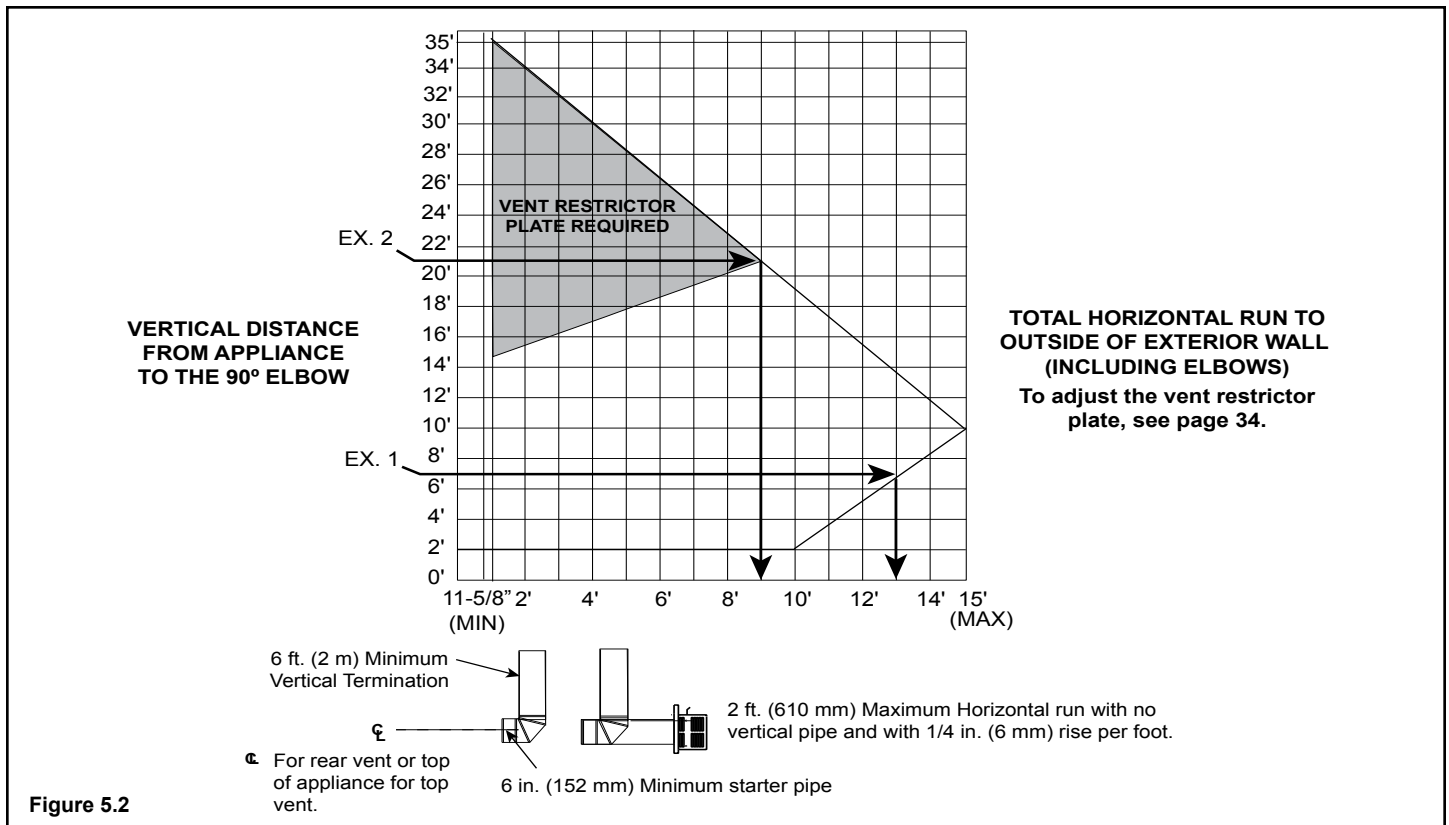


Figure 5.2

## F. Horizontal Termination

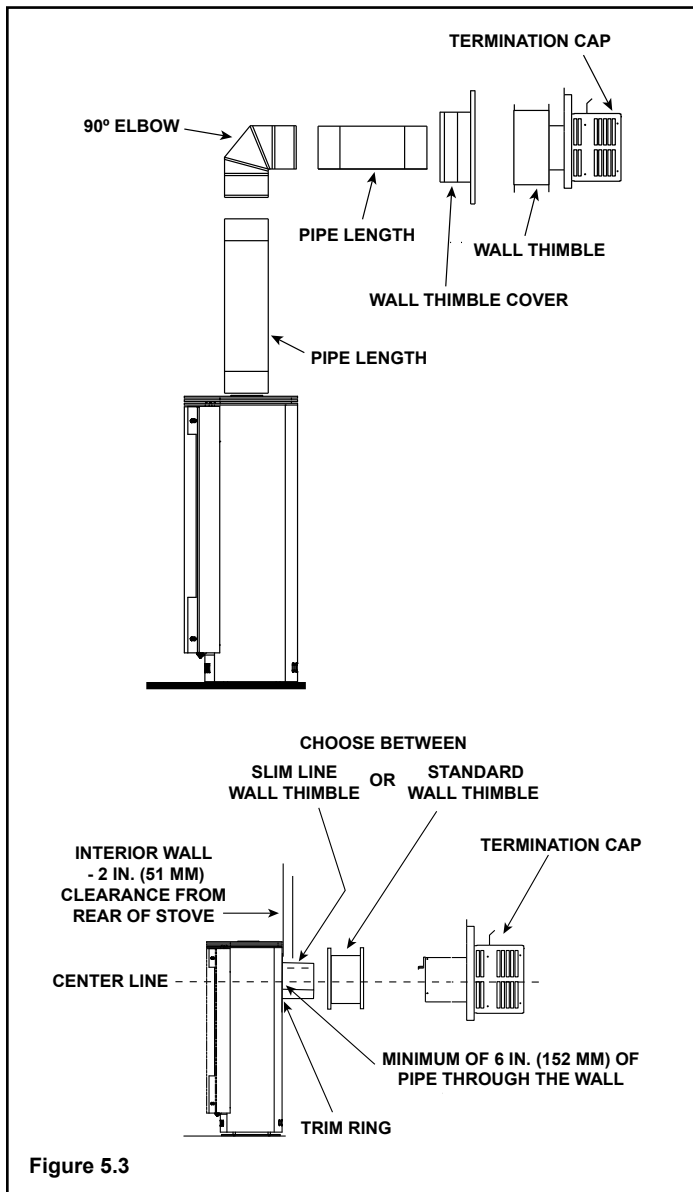


Figure 5.3

1. Determine the desired location of the appliance. Check to ensure that wall studs or roof rafters are not in the way when the venting system is being planned. If this is the case, you may want to adjust the location of the appliance.

WARNING

**Fire Risk**

**Exhaust Fumes Risk**

Impaired Performance of Appliance

- Ensure vent components are locked together correctly.
- Pipe may separate if not properly joined.

2. Direct vent pipe is designed with a locking connection. To connect the venting system to the appliance flue outlet, a twist-lock adapter is built into the appliance at the factory. Wall thickness may vary. Remember to include wall thickness in minimum clearances when figuring venting lengths for your installation needs.
3. Female ends of direct vent pipe/elbows are designed to slide straight onto the male ends of adjacent pipes by orienting the pipe indentations so they match and slide into the entry slots on the male ends, see **Figure 5.4**. Align the seam of the pipe and seam of collar to allow engagement. Rotate the vent component to lock into place. Use this procedure for all vent components. See Figure 10.5. Continue adding vent components, locking each succeeding component into place. Ensure that each succeeding vent component is securely fitted and locked into the preceding component.

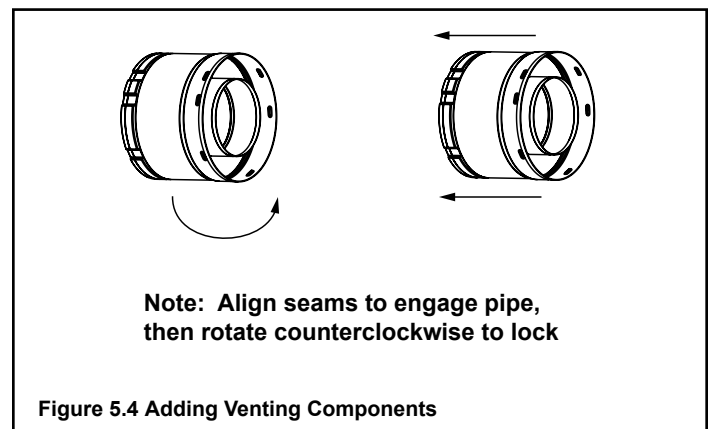


Figure 5.4 Adding Venting Components

WARNING

**Fire Risk.**

**Explosion Risk.**

**Combustion Fume Risk.**

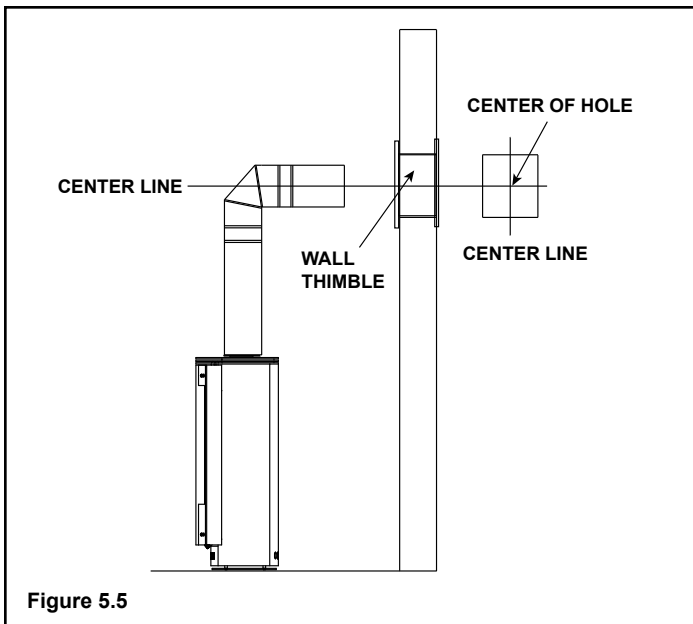
Use vent run supports per installation instructions.

Connect vent sections per installation instructions.

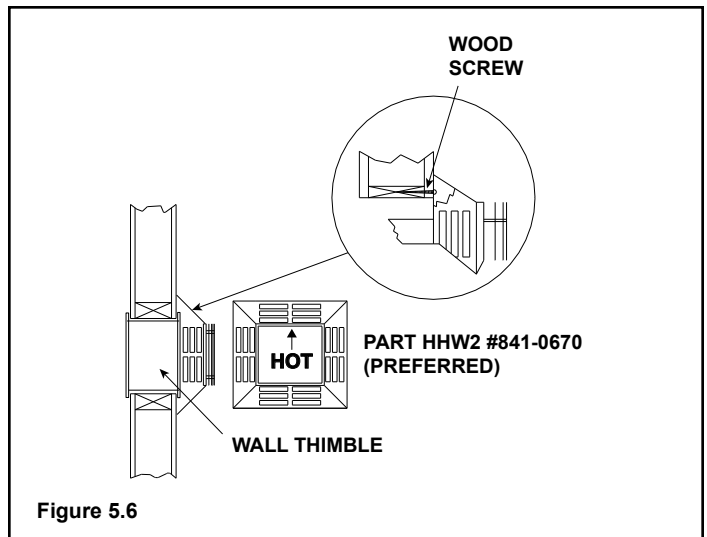
- Maintain all clearances to combustibles.
- Do NOT allow vent to sag below connection point to appliance.
- Maintain specified slope (if required).

Improper support may allow vent to sag or separate.

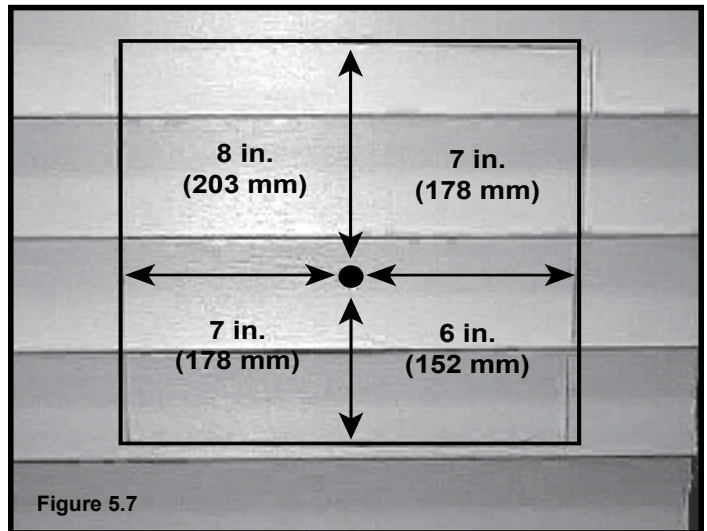
4. For installations using a round support box/wall thimble (check pipe manufacturer's instructions), mark the wall for a 10 in. x 10 in. (254 mm x 254 mm) square hole. The center of the square hole should line up with the center line of the horizontal pipe, as shown in **Figure 5.5**. Cut and frame the hole in the exterior wall where the vent will be terminated. If the wall being penetrated is constructed of noncombustible material, i.e. masonry block or concrete, a 7 in. (178 mm) diameter hole is acceptable.



5. Installation requires a minimum of 6 in. (152 mm) horizontal run of vent with a 1/4 in. (6 mm) rise run towards the termination. Each 1 ft. (305 mm) of horizontal venting must include a 1/4 in. (6 mm) rise. Never allow the vent to run downward. This could cause high temperatures and may present the possibility of a fire. The location of the horizontal vent termination on an exterior wall must meet all local and national building codes, and must not be easily blocked or obstructed, see **Figure 4.4** on page 10.
6. For installations requiring a vertical rise on the exterior of the building, the HHT RHVK snorkel kit (Part #844-8921) is available with a 14 in. (356 mm) and a 36 in. (914 mm) tall snorkel termination cap. Follow the same installation procedures as used for standard horizontal terminations. If the snorkel termination must be installed below grade (i.e. basement application), proper drainage must be provided to prevent water from entering the snorkel termination. Do not backfill around snorkel termination.
7. Position the horizontal termination cap in the center of the 10 in. x 10 in. (254 mm x 254 mm) square hole and run a bead of non-hardening mastic around its outside edges, so as to make a seal between it and the wall, attach termination cap to the exterior wall with the four wood screws provided. The arrow on the vent cap should be pointing up (**Figure 5.6**).



8. The four wood screws provided should be replaced with appropriate fasteners for stucco, brick, concrete, or other types of sidings.
9. Termination cap HHW2 (Part #841-0670) is highly recommended on a building with vinyl siding, as the vinyl siding standoff is built in. The pilot hole will be 2 in. (51 mm) closer to the bottom of the square than the top. Using a framing square, draw a 14 in. x 14 in. (356 mm x 356 mm) square around the pilot hole. See **Figure 5.7**.



10. If you are installing termination cap HHW2, the pipe will be off center on flashing). Ensure that proper clearances to combustible materials are maintained. If you are using an approved termination cap other than HHW2 (part #841-0670) on a building with vinyl siding, a vinyl siding standoff should be installed between the termination cap and the exterior wall (**Figure 5.8**, on the next page). Follow manufacturer's instructions for attaching the vinyl siding standoff to the horizontal termination cap. The vinyl siding standoff prevents excessive heat from possibly melting the vinyl siding material. The vent terminal cap shall not be recessed into a wall or siding. Remove siding from the area where the standoff will be located.

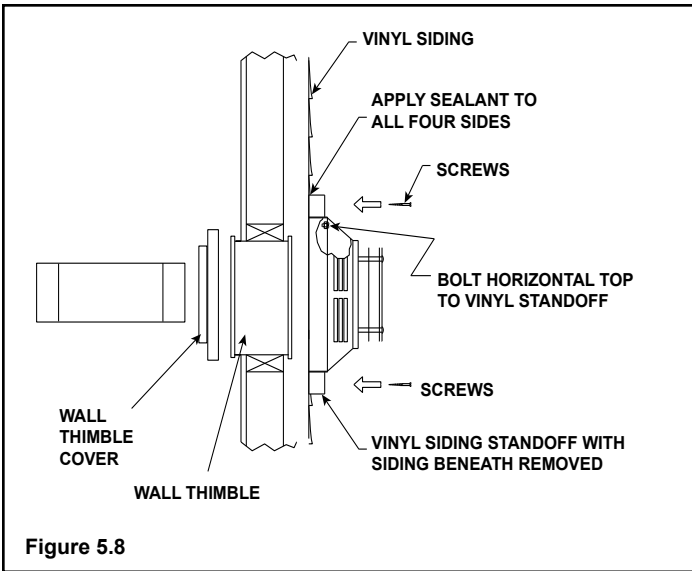


Figure 5.8

11. Place the wall thimble cover over the pipe assembly and slide the appliance and vent assembly towards the wall, carefully inserting the vent pipe into the vent termination cap assembly. It is important that the vent pipe extend into the vent termination cap a sufficient distance so as to result in a minimum pipe overlap of 1-1/4 in. (32 mm). Secure the connection between the vent pipe and the vent termination cap by attaching the two sheet metal strips extending from the vent termination cap assembly into the outer wall of the vent pipe. Use the two sheet metal screws provided to connect the strips to the pipe section (Figure 5.9).

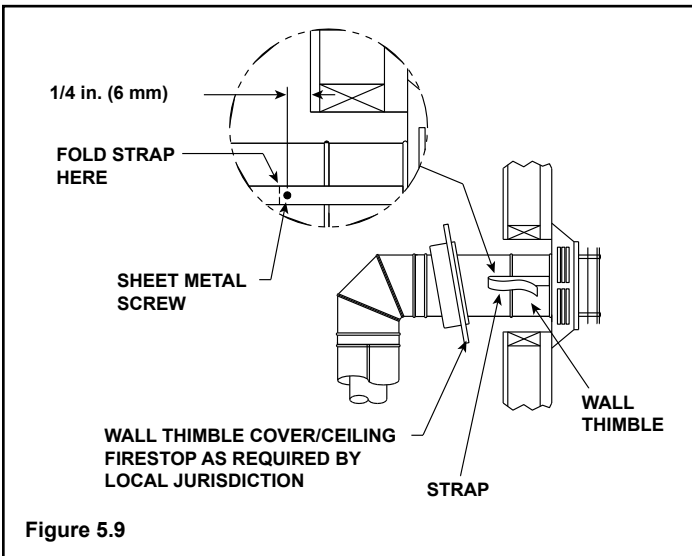


Figure 5.9

**Note:** The attachment from the vent pipe to the vent termination cap must be sealed with silicone. Termination caps shall not be recessed into a wall or siding.

**⚠ WARNING**

**Fire Risk**

**Exhaust Fumes Risk**

Impaired Performance of Appliance

- Ensure vent components are locked together correctly.
- Pipe may separate if not properly joined.

**⚠ WARNING**

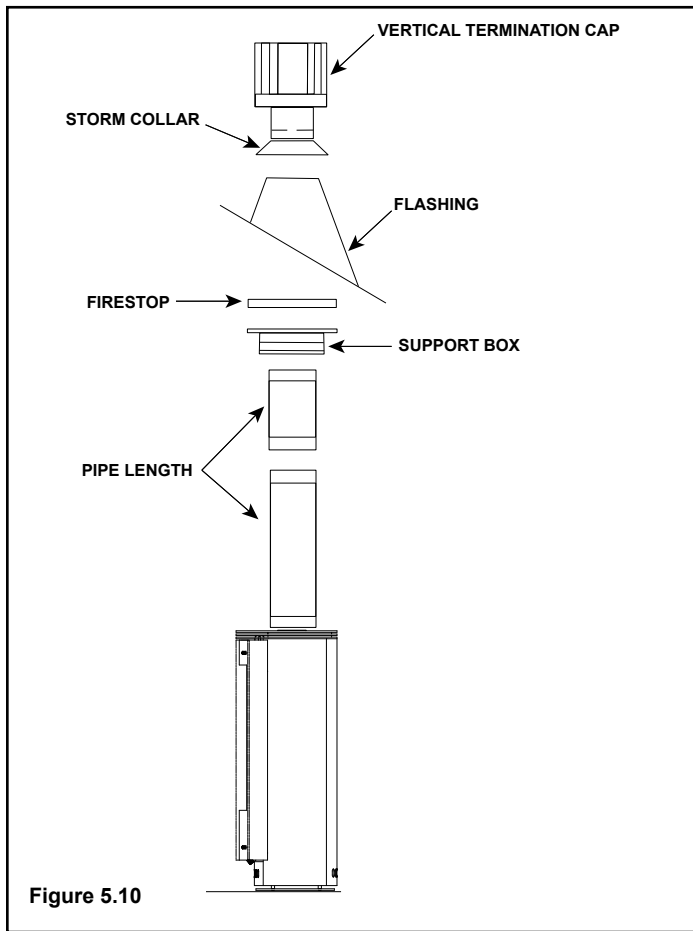
Do NOT connect a pipe section to a termination cap without using the telescoping flue section found on the termination cap.

**⚠ WARNING**

**Burn Risk**

- Local codes may require installation of a cap shield to prevent anything or anyone from touching the hot cap.

## G. Vertical Termination



1. Check the installation instructions for required 1 in. (25 mm) clearances (air space) to combustibles when passing through ceilings, walls, roofs, enclosures, attic rafters, or other nearby combustible surfaces. Check the instructions for maximum vertical rise of the venting system, and any maximum horizontal offset limitations. All offsets must fall within the set parameters of the vent graph (Figure 5.2) located on page 12.

**Note:** Maximum vertical rise allowable is 40 ft. (10.7 m), Figure 5.11. Maximum number of 45° elbows permitted for a vertical installation is eight, provided their installation does not decrease maximum allowable horizontal run (as specified by vent graph, on page 12).

### WARNING



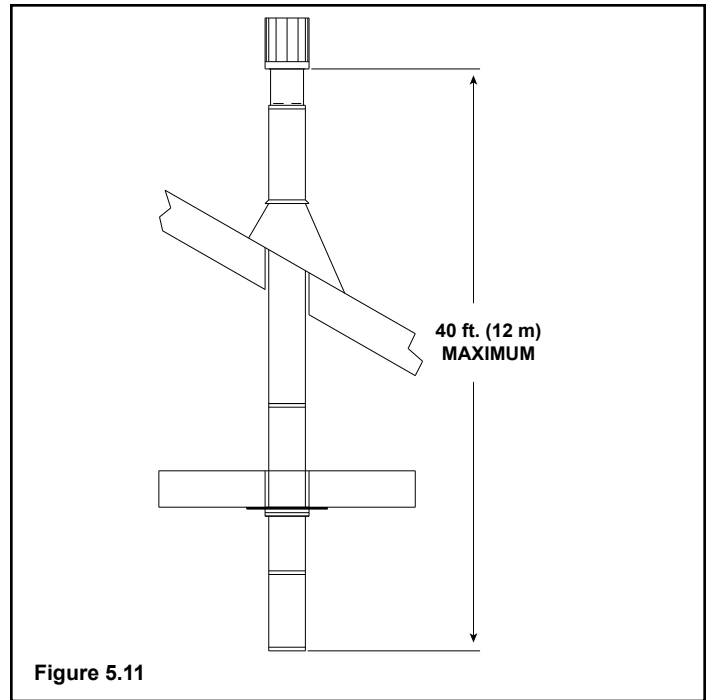
#### Fire Risk.

#### Explosion Risk.

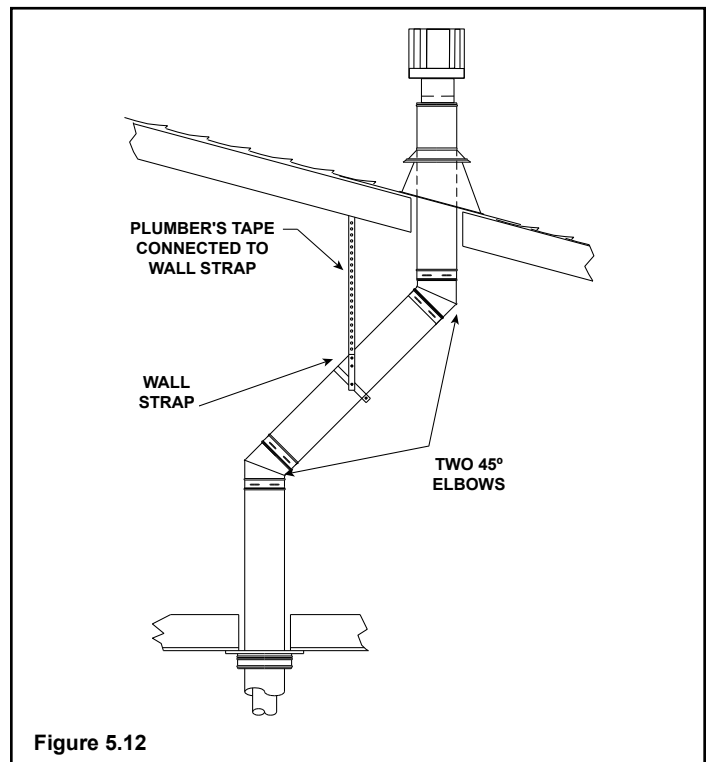
Maintain vent clearance to combustibles as specified.

- Do not pack air space with insulation or other materials.

Failure to keep insulation or other materials away from vent pipe may cause fire.

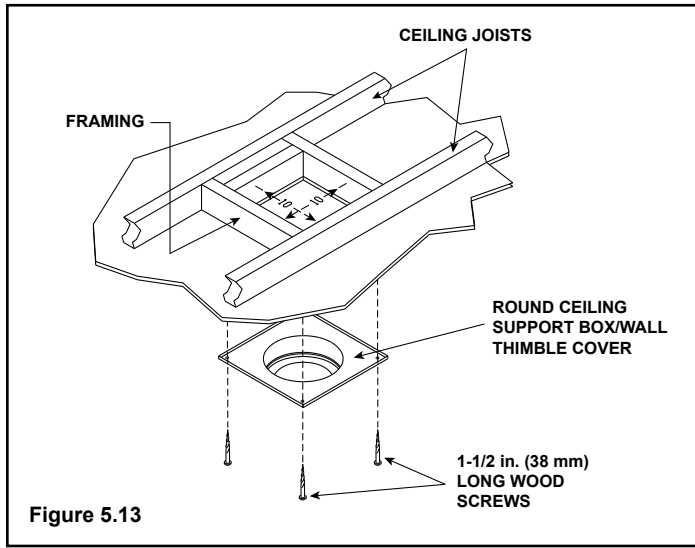


2. Set the gas appliance in its desired location. Drop a plumb bob down from the ceiling to the position of the appliance flue exit, and mark the location where the vent will penetrate the ceiling. Drill a small hole at this point. Next, drop a plumb bob from the roof to the hole previously drilled in the ceiling, and mark the spot where the vent will penetrate the roof. Determine if ceiling joists, roof rafters, or other framing will obstruct the venting system. You may wish to relocate the appliance, or to offset, as shown in Figure 5.12 to avoid cutting load bearing members.

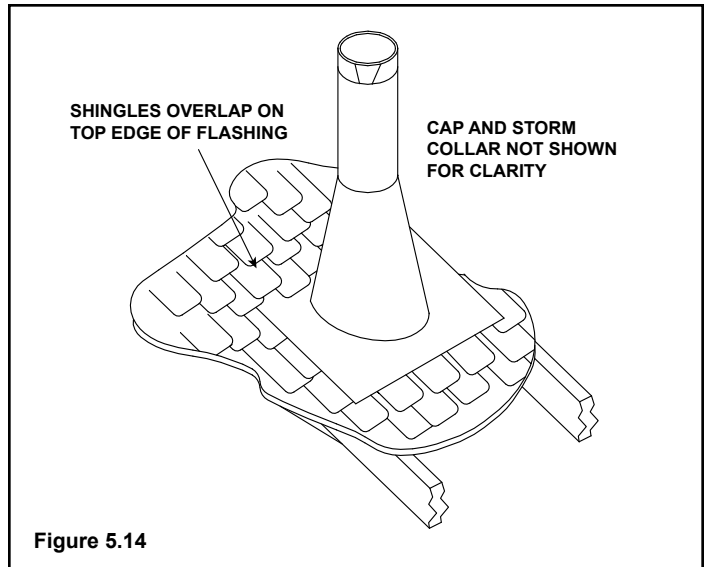




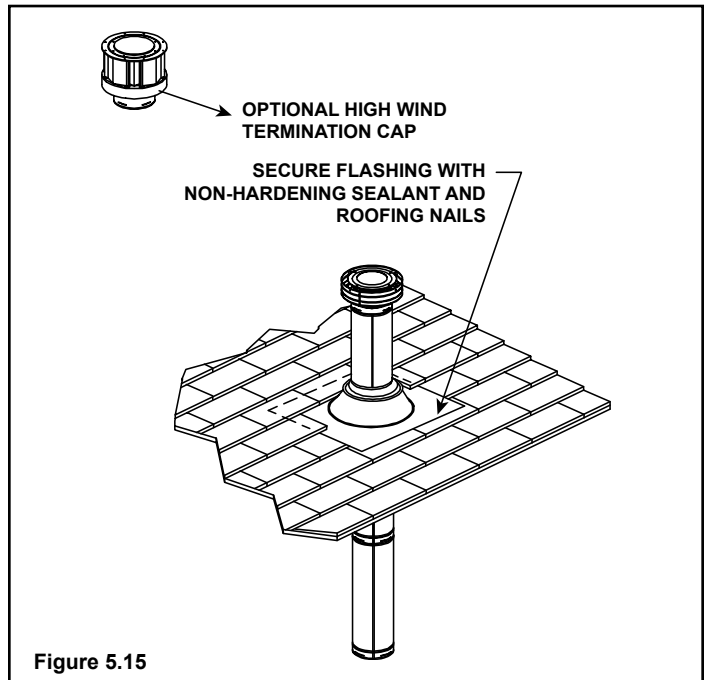
- To install the round support box/wall thimble cover in a flat ceiling, cut a 10 in. (254 mm) square hole in the ceiling, centered on the hole drilled in Step 2. Frame the hole as shown in Figure 5.13.



- Assemble the desired lengths of pipe and elbows necessary to reach from the appliance up through the round support box. Ensure that all pipe and elbow connections are in their fully twist-locked position. Assemble as instructed.
- Cut a hole in the roof centered on the small drill hole placed in the roof in Step 2. The hole should be of sufficient size to meet the minimum requirements for clearance to combustibles, as specified. Continue to assemble lengths of pipe and elbows necessary to reach from the ceiling support box/wall thimble up through the roof line. Galvanized pipe and elbows may be utilized in the attic, as well as above the roofline. The galvanized finish is desirable above the roofline, due to its higher corrosion resistance.
  - If an offset is necessary in the attic to avoid obstructions, it is important to support the vent pipe every 3 ft. (914 mm) to avoid excessive stress on the elbows, and possible separation. Wall straps are available for this purpose, Figure 5.12, page 16.
  - Whenever possible, use 45° elbows, instead of 90° elbows. The 45° elbow offers less restriction to the flow of flue gases and intake air.
- Slip the flashing over the pipe section(s) protruding through the roof. Secure the base of the flashing to the roof with roofing nails. Ensure the roofing material overlaps the top edge of the flashing as shown in Figure 5.14. Verify that the chimney is the required height above the roof. See roof pitch table, Figure 4.2, on page 9.

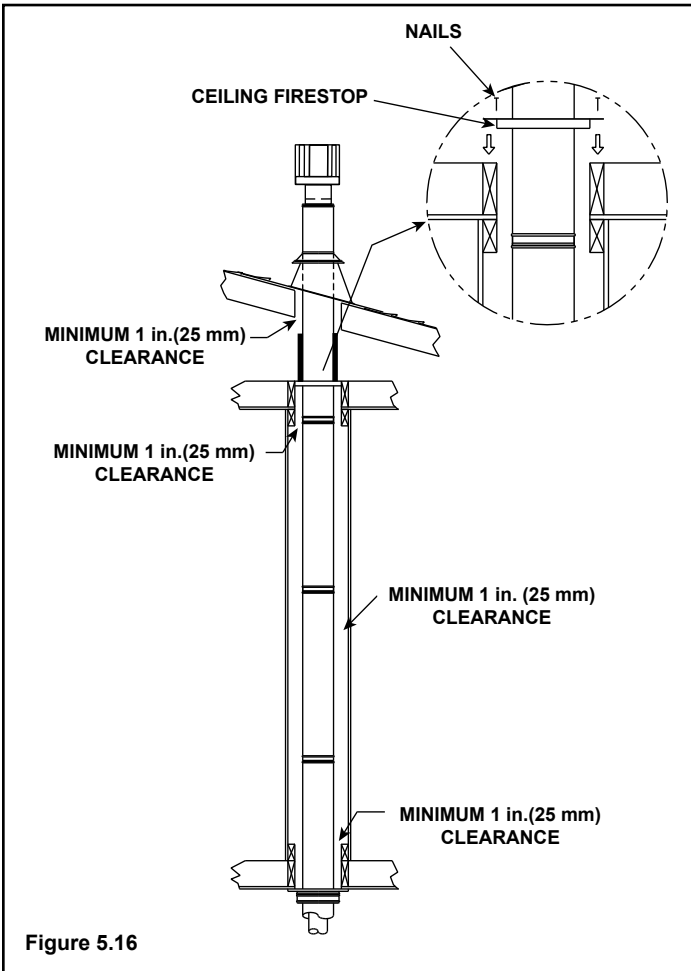


- Continue to assemble pipe sections until the height of the vent (before adding the termination cap) meets the minimum code requirements as outlined in the current CAN/CGA-B149 Installation Codes (in Canada), the National Fuel Gas Code NFPA 54/ANSI Z223.1 (in USA), or local codes. Note that for steep roof pitches, the vent height must be increased. See Roof Pitch Table (Figure 4.2, on page 9). In high wind conditions, nearby trees adjoining rooflines, steep pitched roofs, and other similar factors can result in poor draft, or down drafting. In these cases increasing the vent height or switching to the high wind termination cap may solve this problem.
- Slip the storm collar over the pipe, and push it down to the top of the flashing (Figure 5.15). Use non-hardening sealant above and below the joint between the storm collar and the pipe.



9. Twist-lock the vent cap and seal.

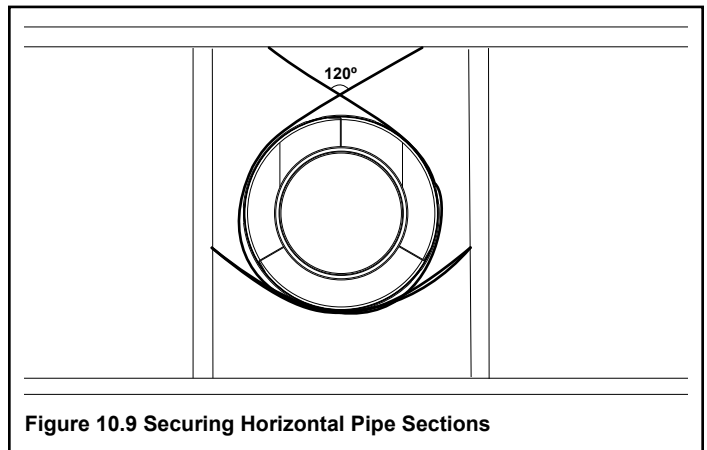
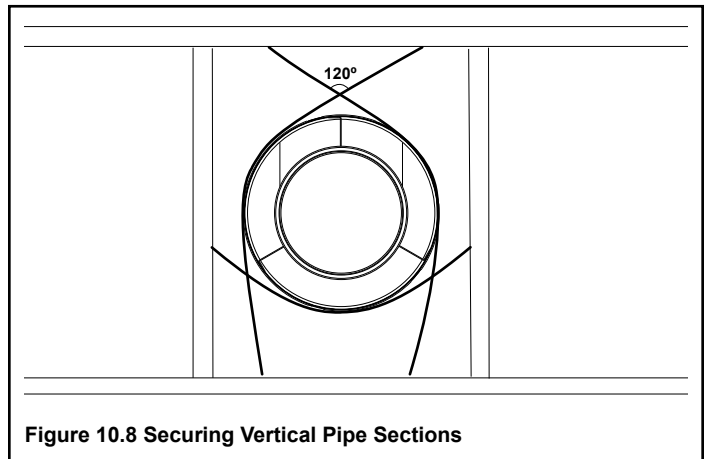
**Note:** For multi-story vertical installations, a ceiling firestop is required at the second floor, and any subsequent floors (Figure 5.16). The opening should be framed to 10 in. x 10 in. (254 mm x 254 mm) inside dimensions, in the same manner as shown in Figure 5.13.



**H. Secure the Vent Sections**

- Vertical runs of SLP pipe must be supported every 8 ft. (2.44 m).
- Horizontal sections must be supported every 5 feet (1.52 m).
- Vent supports or plumbers strap (spaced 120° apart) may be used to support vent sections. See Figures 10.8 and 10.9.
- Wall shield firestops may be used to provide horizontal support to vent sections.
- SLP ceiling firestops have tabs that may be used to provide vertical support.

**WARNING! Risk of Fire, Explosion or Asphyxiation!** Improper support may allow vent to sag and separate. Use vent run supports and connect vent sections per installation instructions. **DO NOT** allow vent to sag below connection point to appliance.



**WARNING**



**Fire Risk.**

**Explosion Risk.**

- Any occupied areas above the first floor, including closets and storage spaces, which the vertical vent passed through must be enclosed. The enclosure may be framed and sheet rocked with standard construction materials; however, refer to these installation instructions for the minimum allowable clearance between the outside of the vent pipe and the combustible surfaces of the enclosure. Do not fill any of the required air space with insulation.

## I. Disassemble Vent Sections

- Rotate either section (see Figure 10.10) so the seams on both pipe sections are aligned as shown in Figure 10.11.
- Pull carefully to separate the pieces of pipe.

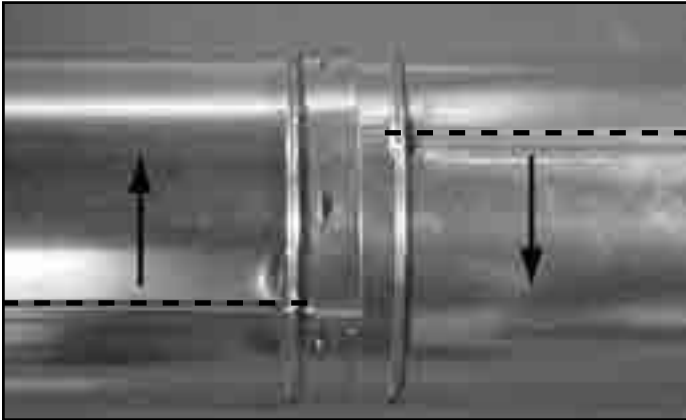


Figure 10.10 Rotate Seams for Disassembly

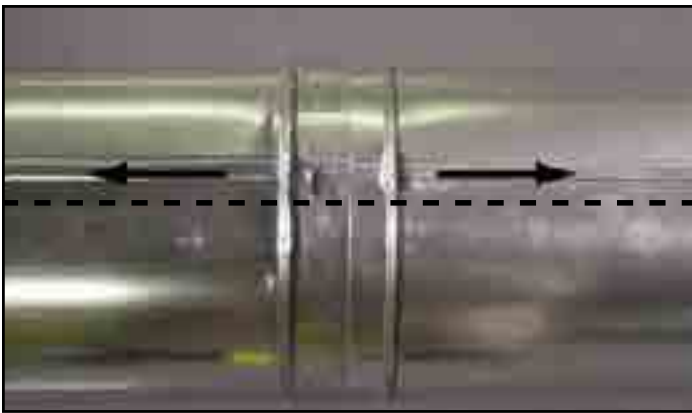


Figure 10.11 Align and Disassemble Vent Sections

## J. Cathedral Ceiling

1. Follow installation Steps 1 and 2 under vertical installation section, page 16.
2. Remove shingles or other roof covering as necessary to cut the rectangular hole for the support box. Cut the hole 1/8 in. (3 mm) larger than the support box outline.
3. Lower the support box through the hole in the roof until the bottom of the support box protrudes at least 2 in. (51 mm) below the ceiling (Figure 5.17). Align the support box both vertically and horizontally with a level. Temporarily tack the support box in place through the inside walls and into the roof sheathing.

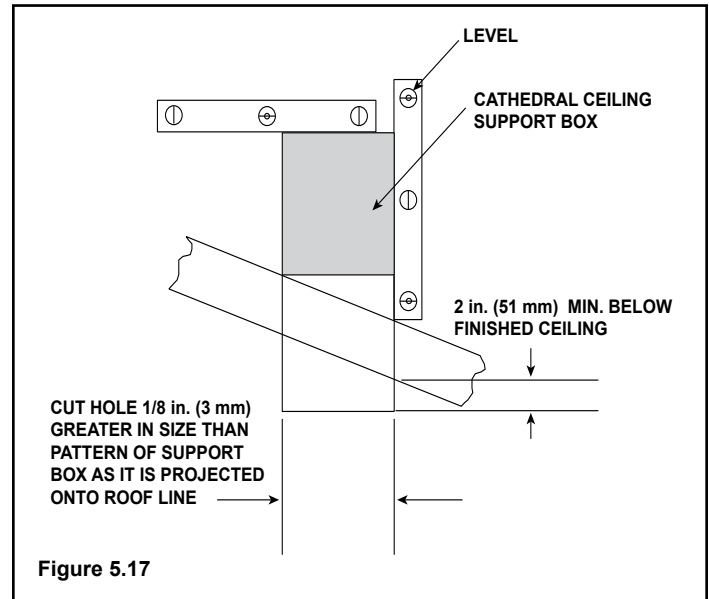


Figure 5.17

4. Using tin snips, cut the support box from the top corners down to the roofline, and fold the resulting flaps over the roof sheathing (Figure 5.18). Before nailing it to the roof, run a bead of non-hardening mastic around the top edges of the support box to make a seal between it and the roof.

**WARNING! Risk of Fire!** Clean out ALL materials from inside the support box and complete the vertical vent run and termination.

5. Assemble the desired lengths of pipe and elbows necessary to reach from the appliance up through the round support box. Ensure that all pipe and elbow connections are in their fully twist-locked position. Assemble as instructed.

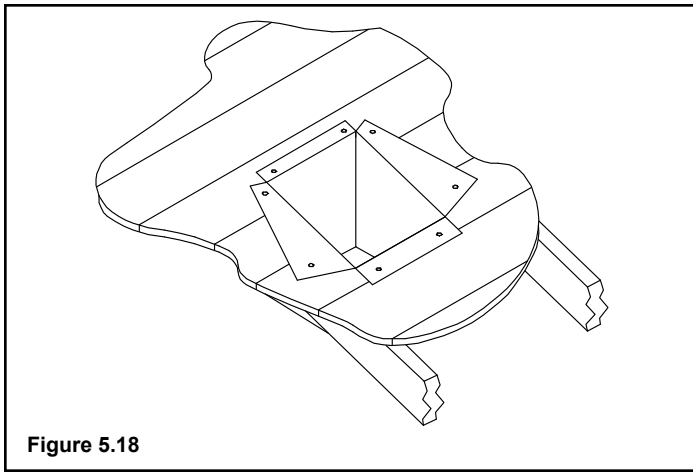


Figure 5.18

6. Place the support clamp (provided with the support box) inside the support box (at the bottom), and secure to the pipe section. The clamp allows the support box to support the weight of the pipe sections. Continue to add pipe sections until you are above the roofline.
7. Complete the cathedral ceiling installation by following the same procedures outlined in steps 7 through 9 for vertical installations, pages 17-18.
8. Install the black trim collar around the outside of the cathedral ceiling support box (Figure 5.19). The two pieces of the trim collar slide over one another to allow for easy adjustment around the support box. Using the six screws provided, secure the four corners and the overlapping sections of the trim collar to the ceiling. You may want to predrill the holes for the overlapped sections for ease of installation.

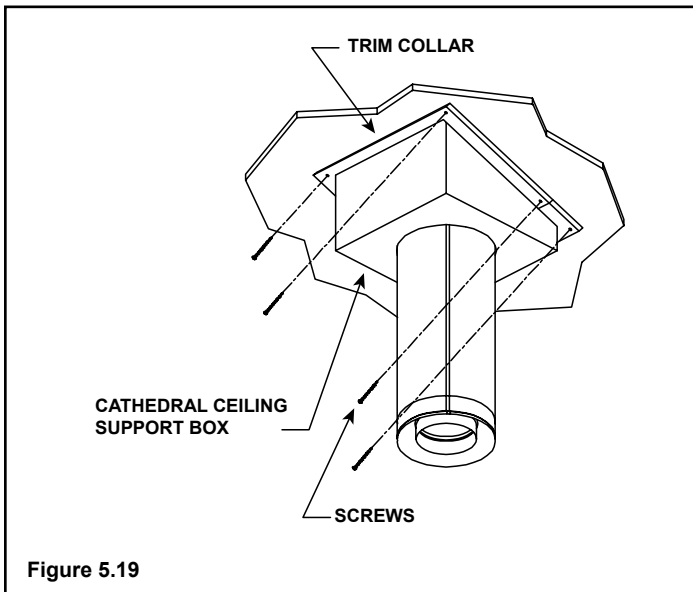


Figure 5.19

## K. Class A Metal Chimney

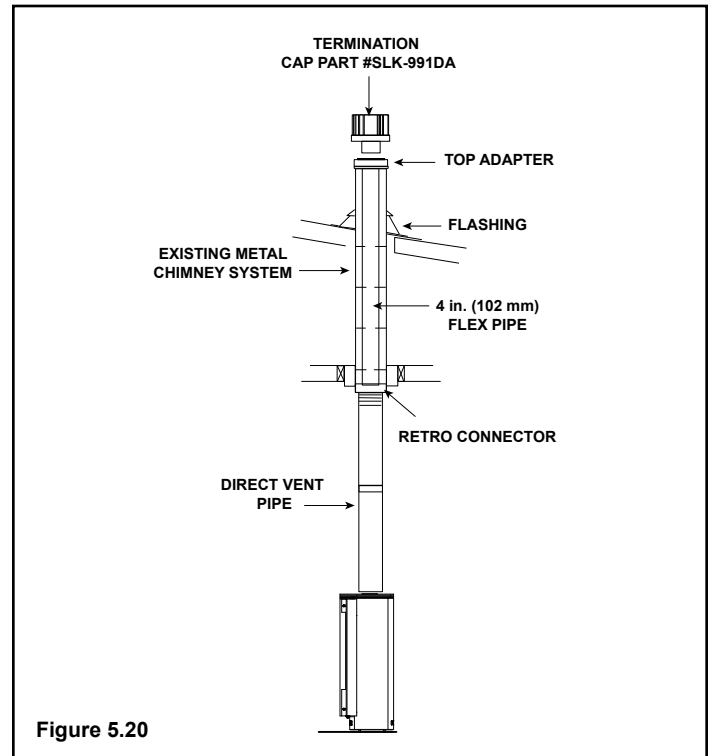


Figure 5.20

### CAUTION

Ensure that existing chimney is functionally sound and clean.

- Have inspection done by qualified chimney sweep or professional installer BEFORE converting to direct vent appliance.

1. Remove existing chimney cap.
2. Measure the distance from the top of the chimney to the bottom of the ceiling support box, add 3 in. (76 mm) to this measurement, and cut a section of 4 in. (101 mm) flex pipe to that length (the flex should be fully extended).
3. Connect the end of the flex pipe section to the underside of the top adapter, using four sheet metal screws (Figure 5.21).

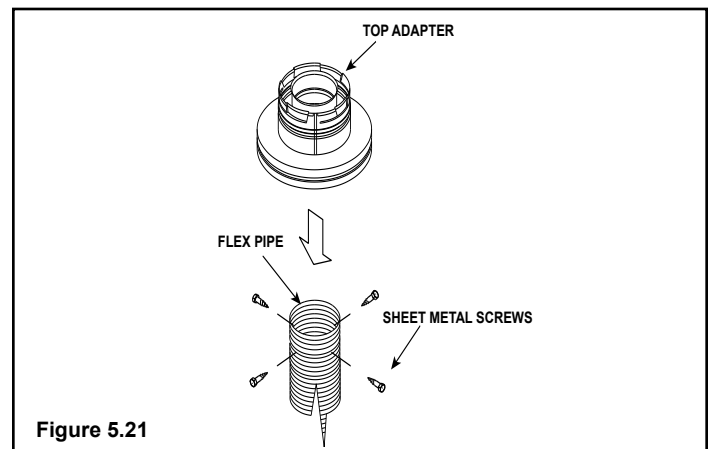
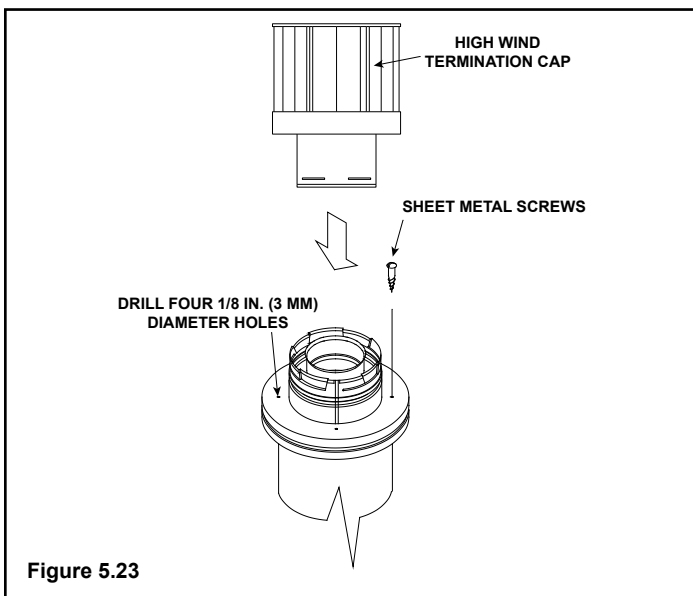
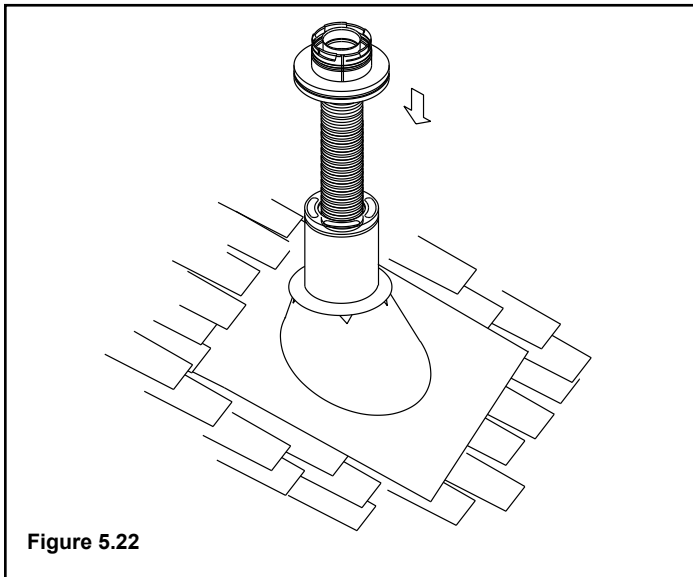


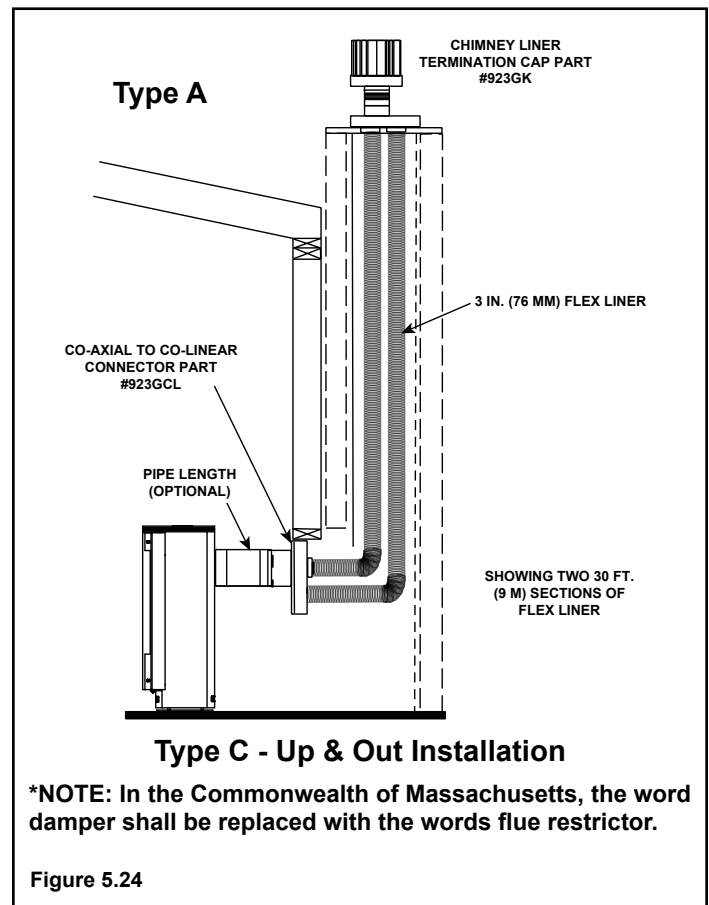
Figure 5.21

4. Pass the flex pipe down through the center of the chimney system, and center the top adapter on the top of the chimney pipe. Drill four 1/8 in. (3 mm) diameter holes through the top adapter, and into the chimney top. Ensure that you are drilling into the metal on the chimney. Twist lock the high wind termination cap onto the top adapter (Figures 5.22 and 5.23).



5. Pull the flex pipe down through the ceiling support box, until it protrudes approximately 3 in. (76 mm). Connect the flex pipe to the retro connector, and attach with sheet metal screws.
6. Push the flex pipe back up into the ceiling support box, center the retro connector, and attach it to the support box with sheet metal screws.
7. The connection between the appliance and the retro connector may be completed with sections of direct vent pipe.

## L. Existing Masonry Chimney

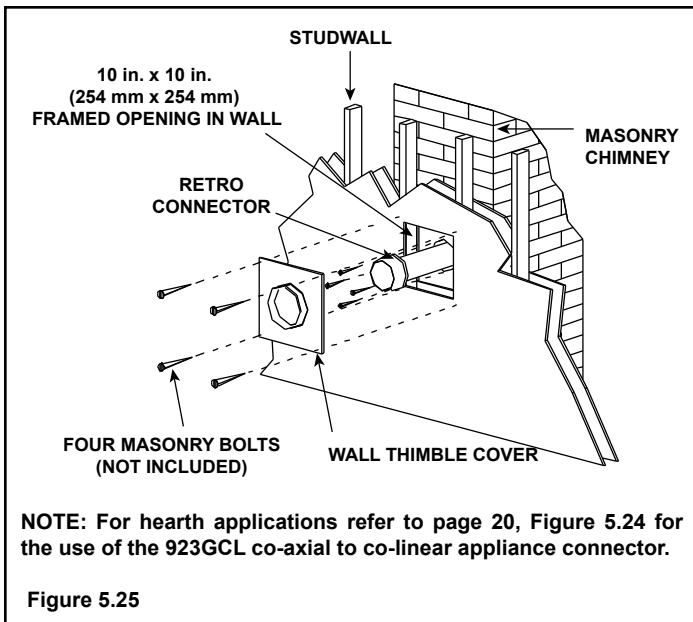


### CAUTION

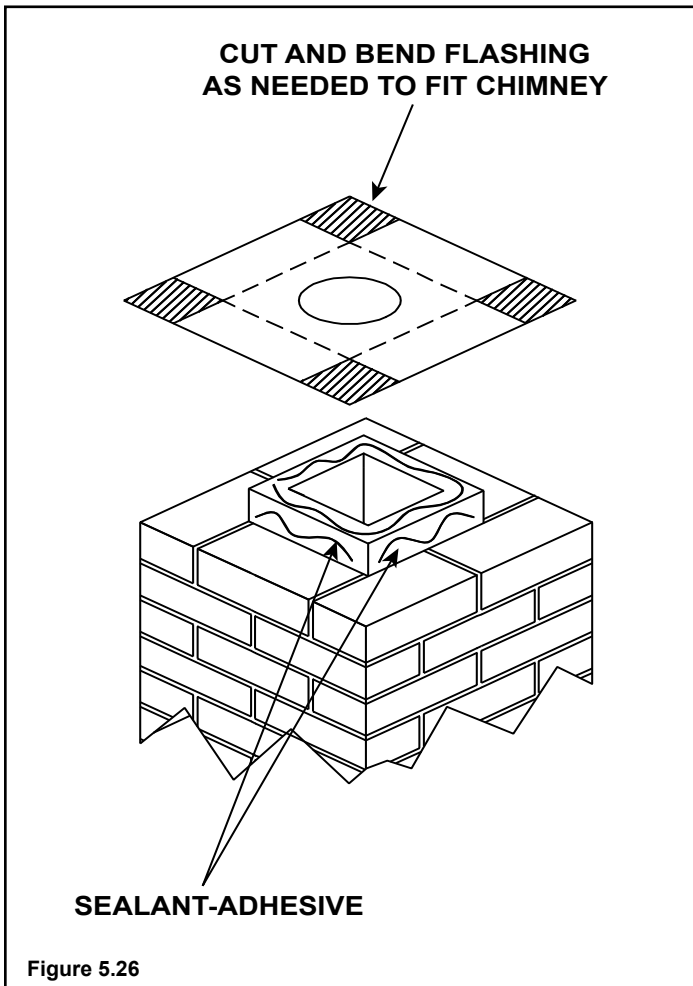
Ensure that existing chimney is functionally sound and clean.

- Have inspection done by qualified chimney sweep or professional installer BEFORE converting to direct vent appliance.

1. Before cutting any holes, assemble the desired sections of direct vent pipe to determine the center of the masonry penetration.
2. Once the center point of the penetration has been determined, cut a 6 in. (152 mm) diameter hole in the masonry. If the hole is too large, the retro connector might not mount properly; if the hole is too small, the appliance might starve for intake air. If there is a frame wall in front of the masonry wall, cut and frame a 10 in. (254 mm) square opening in the wall (centered around the 6 in. (152 mm) masonry opening). If there is sheet rock only (no studs) in front of the masonry the 10 in. (254 mm) opening is still needed, but does not need to be framed. If the hole is framed a round support box/wall thimble is required. This allows the retro connector to mount directly on the masonry and provide the correct clearances to combustibles (Figure 5.25).



3. Secure the flashing to the top of the masonry chimney using a bead of non-hardening sealant-adhesive. If the flashing is larger than the top of the chimney, cut and fold flashing as needed to fit chimney (Figure 5.26).



4. To determine the length of flex needed, measure from 3 in. (76 mm) above the top of the flashing down to the level of the opening. Add the distance from the center of the chimney out through the wall. Cut a piece of 4 in. (102 mm) flex to this length (extended to its nominal length). Be sure to leave 2-3 in. (51-76 mm) of flex above the existing chimney to allow for connection to the termination kit.
5. Connect the flex liner to the top adapter using four sheet metal screws (Figure 5.21).
6. Feed the flex liner through the flashing into the chimney. Carefully feed the flex liner down the chimney to the bottom and out the opening in the masonry wall, forming an angle to line up the flex liner with the vent opening on the appliance.

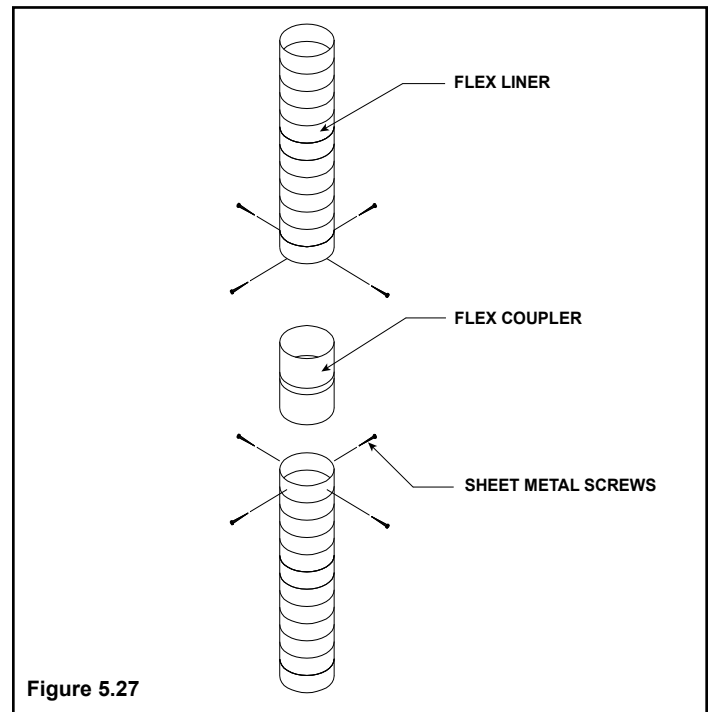
**⚠ WARNING**

**Fire Risk.**

**Explosion Risk.**

- Do not let the flex liner sag below the level at which it will connect to the appliance or connector. This could allow hot gas to become trapped and potentially become a fire hazard. The flex liner path should always be sloped up toward the termination cap.

7. If additional lengths of flex liner are needed to span the chimney height, use a flex coupler to connect the pieces of flex liner together. Connect the flex to the coupler by using four sheet metal screws for each side (Figure 5.27).



8. Secure the top adapter to the flashing. Use three sheet metal screws through the side of the top adapter into the flange on the flashing (Figure 5.28). Twist lock the high wind termination cap on to the top adapter.

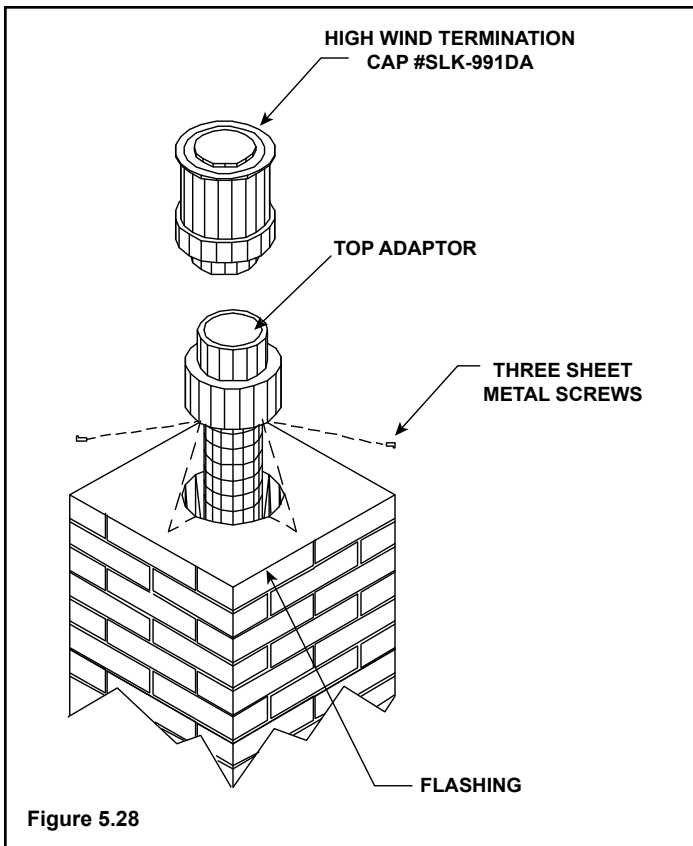


Figure 5.28

9. Attach the flex to the retro connector. Use three sheet metal screws to attach the flex liner to the connector (Figure 5.29). Mount the retro connector to the masonry wall using masonry bolts. Redrill larger holes on connector as needed. Be careful to ensure that the connector is centered in the opening and the mounting holes line up with the masonry wall.

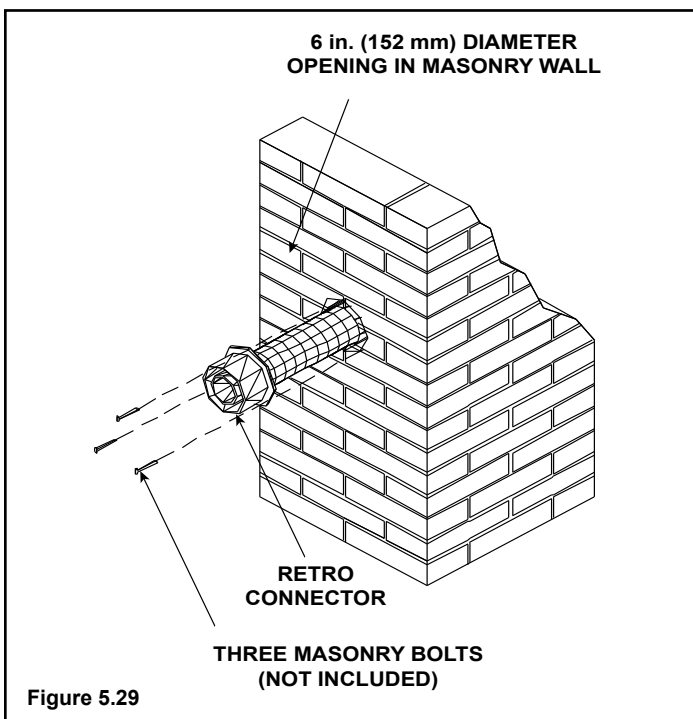


Figure 5.29

10. Slide wall thimble cover over retro connector and secure with masonry bolts (Figure 5.30). If you have a framed wall in front of the masonry, use wood screws to mount wall thimble cover to framed wall, over retro connector and 10 in. (254 mm) square framed opening (Figure 5.25). If needed, add a section of direct vent pipe to the retro connector in order to extend through the opening in the wall thimble cover.

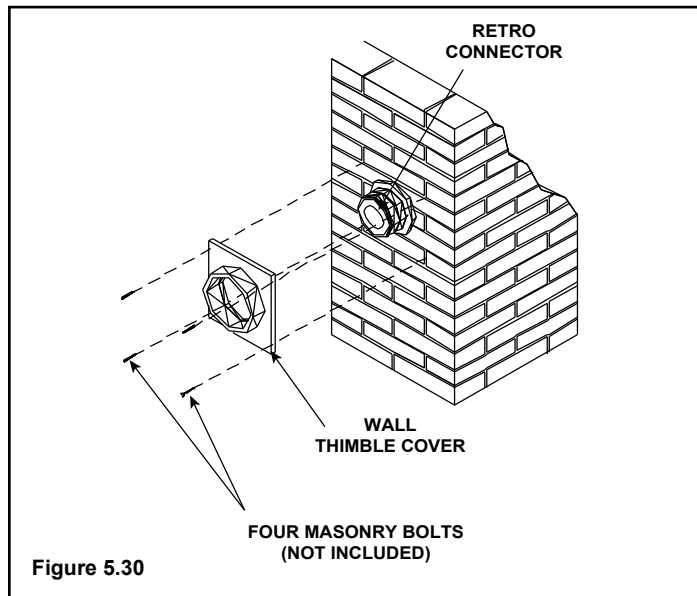


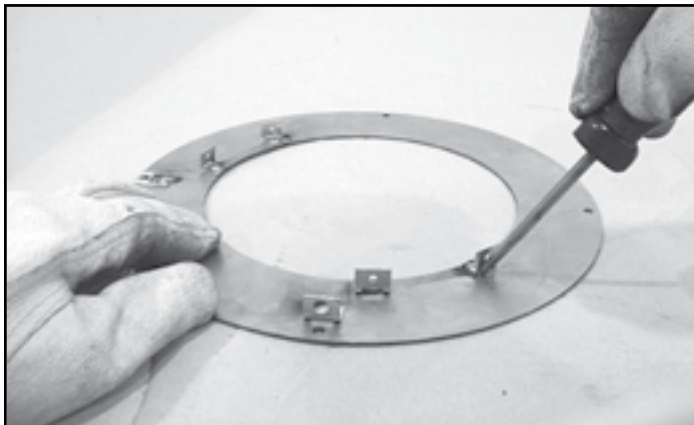
Figure 5.30

11. The connection between the appliance and the retro connector may be completed with sections of direct vent pipe.

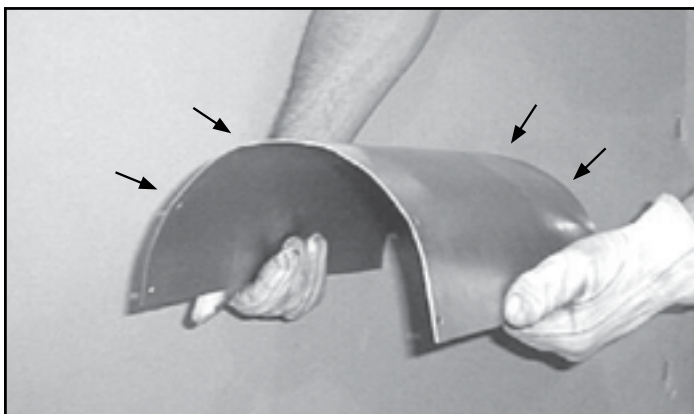
## M. Slim Line Wall Thimble

Before you begin, review the venting configurations in Figures A, B and C on the next page.

### Assembling Slim Line Trim Ring and Heat Shield

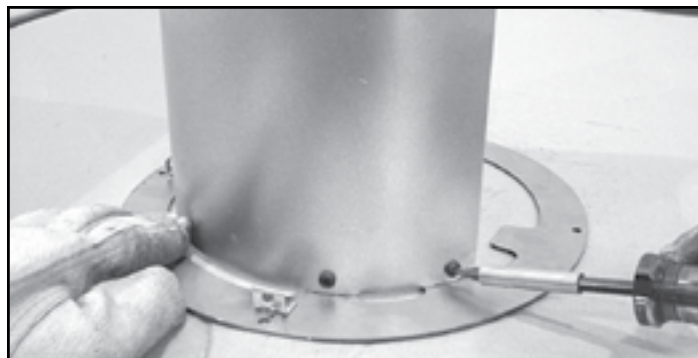


**Figure 5.31** - Lay the trim ring on flat surface and bend up the six welded brackets into a 90 degree position. The brackets along the outer edge of the ring are for locating the ring in the center of the hole.



**Figure 5.32** - The heat shield is shipped flat and must be hand bent into a half circle before attaching it to the trim ring. Bend the heat shield as shown.

**CAUTION! Risk of Cuts.** Wear protective gloves and safety glasses during installation. Sheet metal edges are sharp.

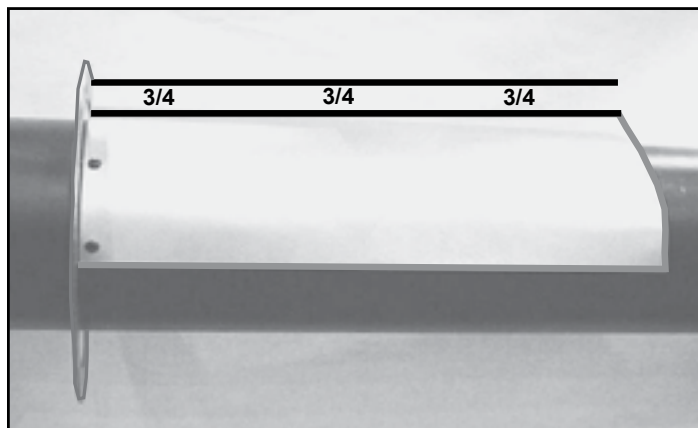


**Figure 5.33** - Attach the heat shield to the trim ring with the four screws provided. Screws go through the heat shield and into the brackets on the trim ring.

### Installing Slim Line Trim Ring and Heat Shield

Measure from the floor to the center of the vent pipe. Cut out a 9-1/2 in. (241 mm) hole in the wall. Hold the trim ring/heat shield assembly in place and put a mark on the shield where it protrudes through the exterior wall. See **Figure A** on the next page.

Use that mark as a guide to trim off excess heat shield with a pair of sheet metal shears.



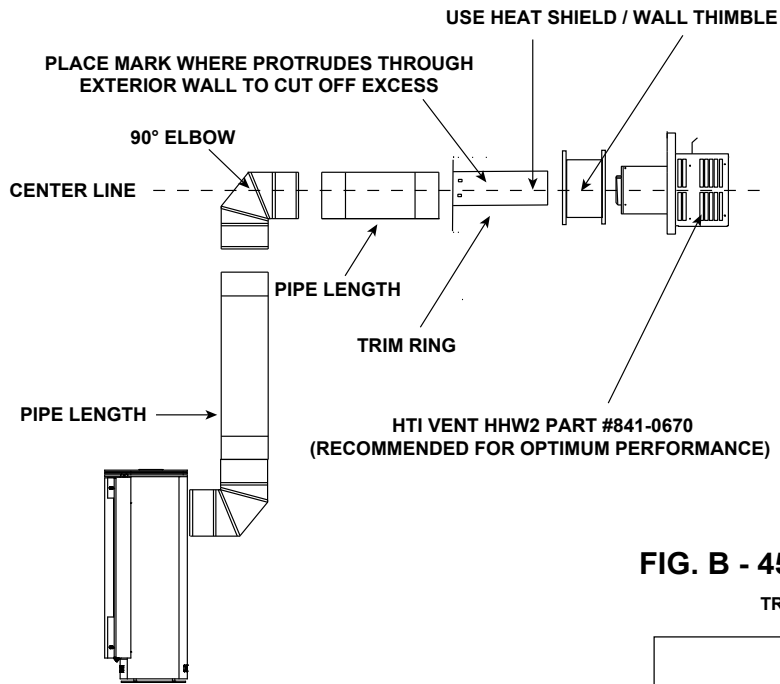
**Figure 5.34** - When installing the trim ring/heat shield assembly make sure the trim ring is centered in the hole and that the shield is above the pipe. There must be a minimum of 3/4 in. (19 mm) minimum clearance maintained to combustibles from the top of the heat shield.

Ensure that framing on the inside of the wall is a minimum inner framing diameter of 10 in. x 10 in. (254 mm x 254 mm).

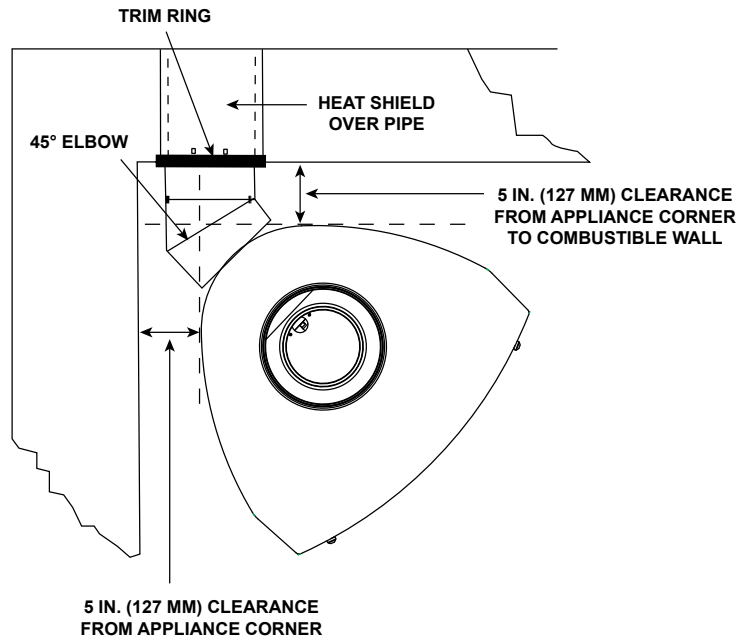
The four trim ring mounting screws provided should be replaced with appropriate fasteners for stucco, brick, concrete, or other types of sidings.



### FIG. A - 90 DEGREE ELBOW



### FIG. B - 45 DEGREE ELBOW



### FIG. C - MINIMUM CLEARANCE

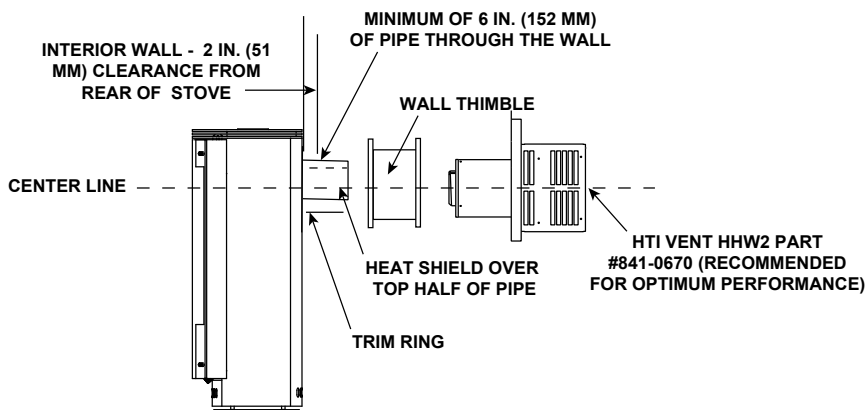


Figure 5.35

# 6 Gas Information

## A. Fuel Conversion


- Make sure the appliance is compatible with available gas types.
- Conversions must be made by a qualified service technician using Hearth & Home Technologies specified and approved parts.



## B. Gas Pressures

Proper input pressures are required for optimum appliance performance. Gas line sizing requirements need to be made following NFPA54.

Pressure requirements for appliance are shown in the table below. Minimum pressures must be met when other household gas appliances are operating.

Pressure	Natural Gas	Propane
Minimum inlet pressure	5.0 inches w.c.	11.0 inches w.c.
Maximum inlet gas pressure	7.0 inches w.c.	14.0 inches w.c.
Manifold pressure	3.5 inches w.c.	10.0 inches w.c.

 **WARNING**

**Fire Risk.**  
**Explosion Hazard.**


High pressure will damage valve.



- Disconnect gas supply piping BEFORE pressure testing gas line at test pressures above 1/2 psig.
- Close the manual shutoff valve BEFORE pressure testing gas line at test pressures equal to or less than 1/2 psig.

If the pressure is not sufficient, ensure:

- The piping used is large enough.
- The supply regulator is adequately adjusted.
- That the total gas load for the residence does not exceed the amount supplied.

The supply regulator (the regulator that attaches directly to the residence inlet or to the propane tank) should supply gas at the suggested input pressure listed above. Contact the local gas supplier if the regulator is at an improper pressure.

 **WARNING**

Verify inlet pressures.

- High pressure may cause overfire condition.
- Low pressure may cause explosion.
- Verify minimum pressures when other household gas appliances are operating.

Install regulator upstream of valve if line pressure is greater than 1/2 psig.

## C. Gas Connection

**Note:** Have the gas supply line installed in accordance with local building codes, if any. If not, follow ANSI 223.1. Installation should be done by a qualified installer approved and/or licensed as required by the locality. (In the Commonwealth of Massachusetts installation must be performed by a licensed plumber or gas fitter).

**Note:** A listed (and Commonwealth of Massachusetts approved) 1/2 inch (13 mm) T-handle manual shut-off valve and flexible gas connector are connected to the 1/2 inch (13 mm) control valve inlet.

- **If substituting for these components, please consult local codes for compliance.**

### WARNING



#### Gas Leak Risk

- Support control when attaching pipe to prevent bending gas line.

**Note:** The gap between supply piping and gas access hole may be caulked with caulk with a minimum of 300°F continuous exposure rating or stuffed with non-combustible, unfaced insulation to prevent cold air infiltration.

Leak test all gas line joints and the gas control valve prior to and after starting the appliance.

Before making the gas connection, ensure that the appliance you are installing is designed for the type of gas being supplied. This information can be found on the ratings label under the appliance. If the appliance has been converted to propane (LP), the valve cover should have a label stating that the appliance has been converted to propane.

Connect the gas line at the 3/8 in. (10 mm) pipe connector on the valve at the back of appliance. We recommend connecting the appliance with an approved flex gas line. If flex gas lines are not approved in your area, you must connect a hard pipe to the gas hookup.

You must supply a manual shut-off valve in a visible location within 3 ft. (914 mm) of the appliance.

### WARNING



#### Fire or Explosion Hazard

- Gas buildup during line purge may ignite.
- Purge should be performed by qualified technician.
- Ensure adequate ventilation.
- Ensure there are no ignition sources such as sparks or open flames.



- A small amount of air will be in the gas supply lines. When first lighting appliance it will take a short time for air to purge from lines. When purging is complete the appliance will light and operate normally.

Air only needs to be purged again if gas valve has been turned to the OFF position.

### WARNING



#### CHECK FOR GAS LEAKS

##### Explosion Risk

##### Fire Risk

##### Asphyxiation Risk

- Check all fittings and connections.
- Do not use open flame.



- After the gas line installation is complete, all connections must be tightened and checked for leaks with a commercially-available, non-corrosive leak check solution. Be sure to rinse off all leak check solution following testing.

Fittings and connections may have loosened during shipping and handling.

### WARNING



#### Fire hazard.

Do NOT change the valve settings.

- This valve has been preset at the factory.
- Changing valve settings may result in fire hazard or bodily injury.

#### HIGH ALTITUDE INSTALLATIONS

Omni-Test Laboratories, Inc. listed gas appliances are tested and approved without requiring changes for elevations from 0 to 2000 feet in the U.S.A. and 0 to 4500 feet in Canada.

When installing this appliance at an elevation above 2000 feet, it may be necessary to decrease the input rating by changing the existing burner orifice to a smaller size. Input rate should be reduced by 4% for each 1000 feet above a 2000 foot elevation in the U.S.A. If the heating value of the gas has been reduced, these rules do not apply. To identify the proper orifice size, check with the local gas utility.

If installing this appliance at an elevation above 4500 feet (in Canada), check with local authorities.

# 7 Electrical Information


## A. Recommendation for Wire



See Figure 7.1 for recommended maximum lead length (two wire) when using wall thermostat/switch.

**NOTE:** This appliance must be electrically wired and grounded in accordance with local codes or, in the absence of local codes, with **National Electric Code ANSI/NFPA 70-latest edition** or the **Canadian Electric Code, CSA C221.1**.

- A 110-120 VAC circuit for this product must be protected with ground-fault circuit-interrupter protection, in compliance with the applicable electrical codes, when it is installed in locations such as in bathrooms or near sinks.

## B. Connecting to the Appliance


**WARNING**

Wire 110-120 VAC to electrical junction box.  
Do NOT wire 110-120 VAC to valve.  
Do NOT wire 110-120 VAC to wall switch.

- Incorrect wiring will damage millivolt valves.
- Incorrect wiring will override IPI safety lockout and may cause explosion.

1. This appliance may be used with a wall switch, wall mounted thermostat and / or a remote control
2. If using thermostat, use one compatible with a millivolt gas valve system.
3. Follow parameters for locating thermostat (see individual thermostat instructions) to ensure proper operation of appliance.
4. Use low resistance thermostat wire for wiring from ignition system to the wall switch and thermostat.
5. Use the following chart for wire sizing.


Wire Size	Max. Length
16 gauge	65 feet
18 gauge	40 feet
20 gauge	25 feet
22 gauge	18 feet


Figure 7.1

6. Keep wire lengths as short as possible by removing any excess wire length.
7. Low voltage and 110-120 VAC voltage cannot be shared within the same wall box.
8. Ensure the thermostat is mounted level for accurate readings.
9. The thermostat should be mounted on an inside wall and not in direct line with the appliance convection air.
10. If the thermostat is located too close to the appliance, you may need to set the temperature setting slightly higher to maintain the desired temperature in your home.

**Do not connect this appliance to a thermostat serving any other appliance.**

**Bedroom installation in Canada requires this appliance to be connected to a thermostat.**


**WARNING**



Shock hazard.

- This appliance is equipped with a three pronged (grounding) plug for your protection against shock hazard and should be plugged directly into a properly grounded three prong receptacle. Do not cut or remove the grounding prong from this plug.

## C. IntelliFire® Ignition System Wiring

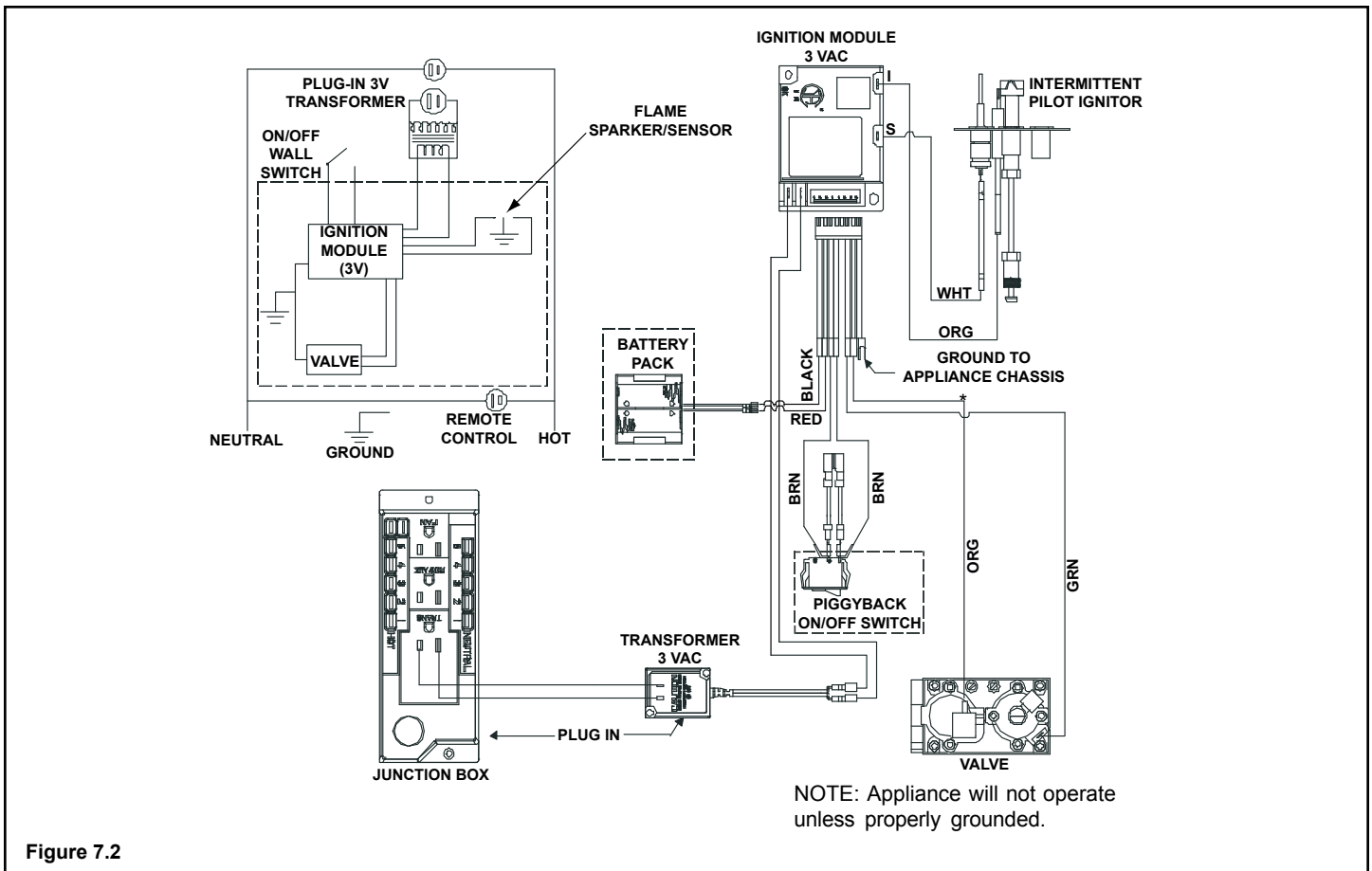
This appliance requires a 110-120 VAC supply to the appliance junction box for operation. A wiring diagram is shown in **Figure 7.2** on the next page.

This appliance is equipped with an IntelliFire® control valve which operates on a 3 volt system.

This appliance is supplied with a 3 volt AC transformer, which requires the installation of the supplied junction box.

This appliance is supplied with a battery pack that requires two D cell batteries (not included). Batteries cannot be placed in the battery pack while using the 3 volt AC transformer. Conversely, the transformer must be unplugged if the battery pack is used.

**NOTICE:** Battery polarity must be correct or module damage will occur.



**CAUTION**

Label all wires prior to disconnection when servicing controls. Wiring errors can cause improper and dangerous operation. Verify proper operation after servicing.

#### D. Loss of Power and Battery Backup Usage

1. Disconnect the power supply.
2. Remove the front door assembly and lower access panel.
3. Place two "D" cell batteries into the battery holder. (Figure 7.3)
4. Turn on appliance and verify it is operational.
5. Replace lower access panel and front door assembly.

**CAUTION**

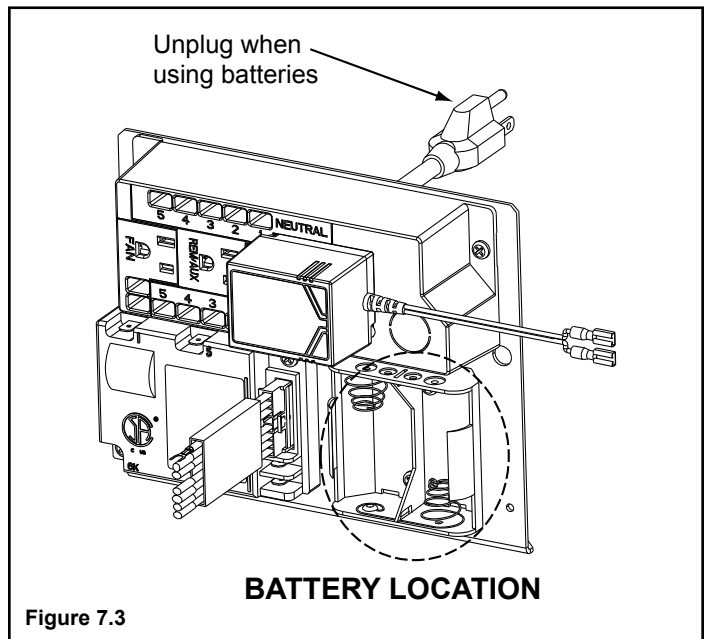
If IPI battery back-up is installed:

- Do not install batteries if the backup mode may not be used for extended time.
- Batteries may leak.
- Install batteries only when needed for power outage.

**WARNING**

Shock hazard.

- Replace damaged wire with type 105° C rated wire.
- Wire must have high temperature insulation.



## E. Wall Switch Installation for Fan (Optional)

If the box is being wired to a wall mounted switch for use with a fan (See Figure 7.4):

- The power supply for the appliance must be brought into a switch box.
- The power can then be supplied from the switch box to the appliance using a minimum of 14-3 with ground wire.
- At the switch box connect the black (hot) wire and red (switch leg) wire to the wall switch as shown.
- At the appliance connect the black (hot), white (neutral) and green (ground) wires to the junction box as shown.
- Add a 1/4 inch insulated female connector to the red (switch leg) wire, route it through the knockout in the face of the junction box, and connect to the top fan switch connector (1/4 inch male) as shown.

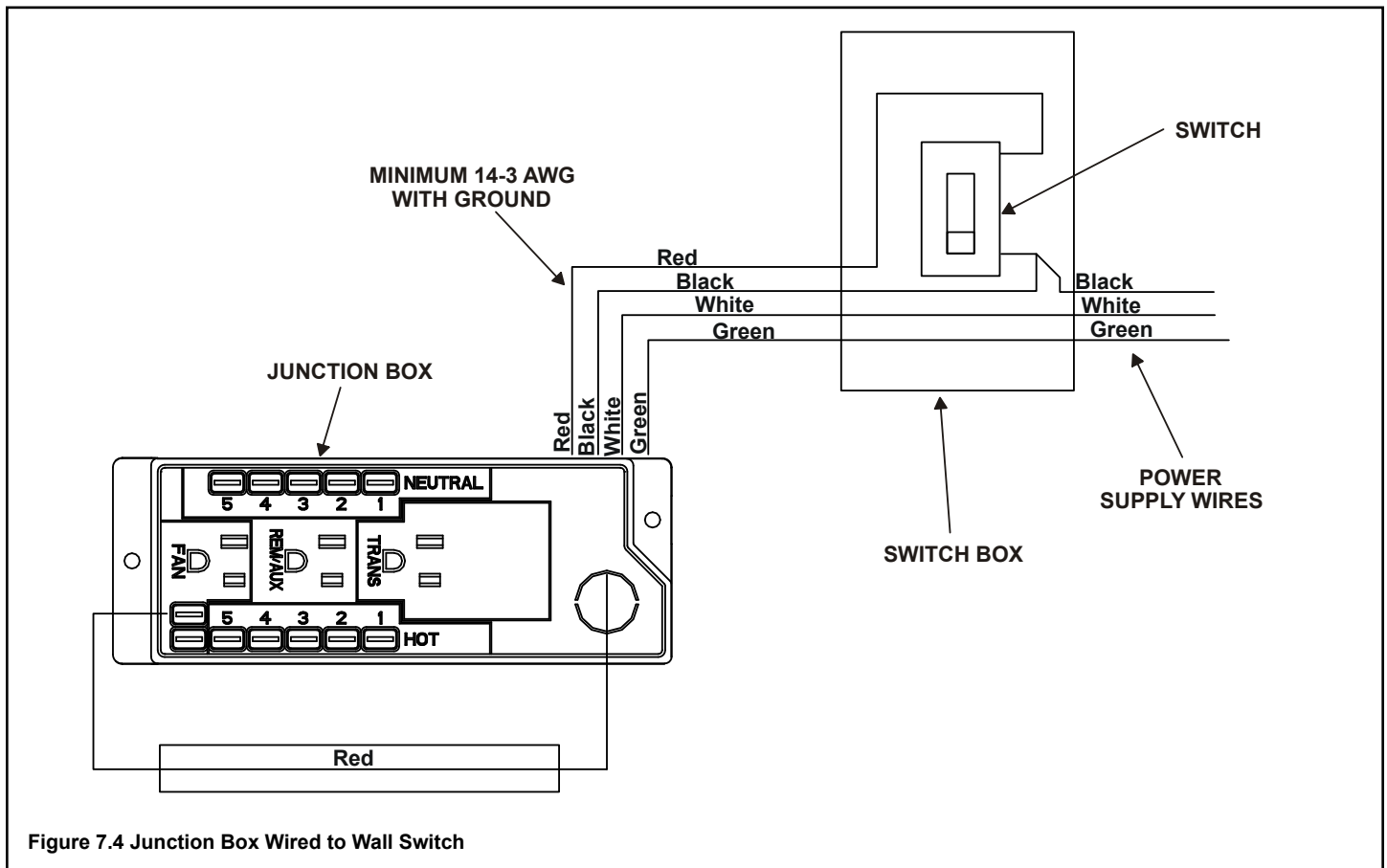


Figure 7.4 Junction Box Wired to Wall Switch

# 8 Appliance Setup

## A. Remove Shipping Materials

Remove shipping materials from inside or underneath the firebox.

Gas line and power cord are shipped inside back panel. To access the gas line and power cord, remove the top plate from the appliance. Remove and retain the two Allen head screws that hold the back panel in place. Refer to Figure 8.8.

Using the black grommet located in the component bag, slide it into the bottom of the back panel and feed the power cord through the grommet, as shown in Figure 8.1.



Figure 8.1

## B. Unbolting Appliance from the Pallet

The appliance is bolted and screwed to the pallet for shipping. Use a 1/2 in. socket to remove the bolt in center of bottom plate. Use a Phillips screwdriver to remove the two screws in the front of the bottom plate and the two screws holding the metal strap across the back of the appliance. Refer to Figure 8.2 for locations.

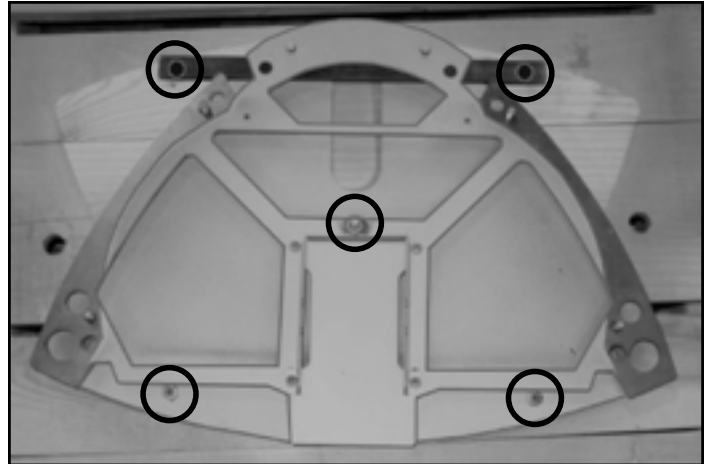





Figure 8.2

### C. Leveling and Lagging Down the Appliance

Lagging the appliance down is **REQUIRED**.

 <b>WARNING</b>	
 	<p><b>Fire Risk.</b></p> <p><b>Odor Risk.</b></p> <p><b>Tipping Risk</b></p> <ul style="list-style-type: none"> <li>• Install gas stove on a stable, level platform/floor strong enough to support gas stove without tipping.</li> <li>• <u>USE</u> wood flooring, ceramic tile, brick hearth or high pressure laminate flooring applied directly over the sub-flooring material.</li> </ul>

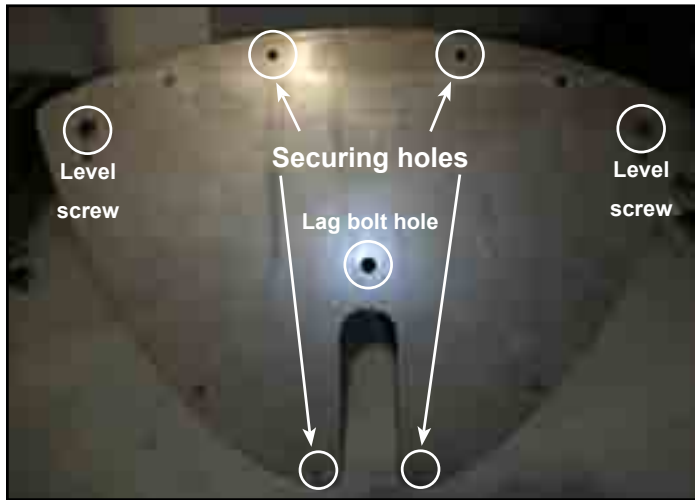


Figure 8.3



Figure 8.4

After unbolting the appliance from the pallet, insert two 1/4 20 x 1 1/2 counters crews.

Using pliers, adjust the counters crews to level the appliance.

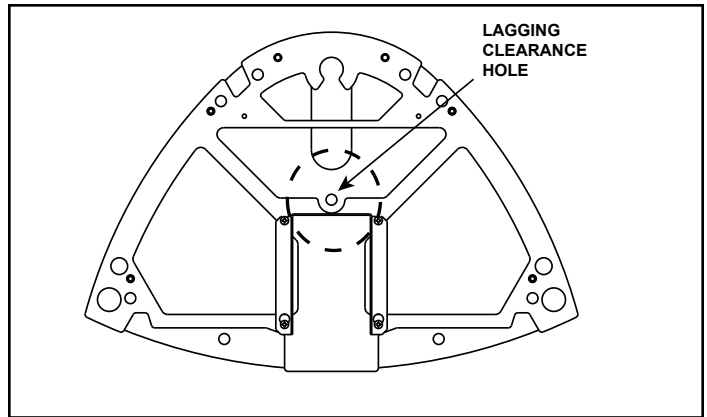


Figure 8.5

Place the lag bolt from the component bag in the center hole in the bottom plate (lagging clearance hole). The appliance must be lagged down securely to prevent tipping forward.

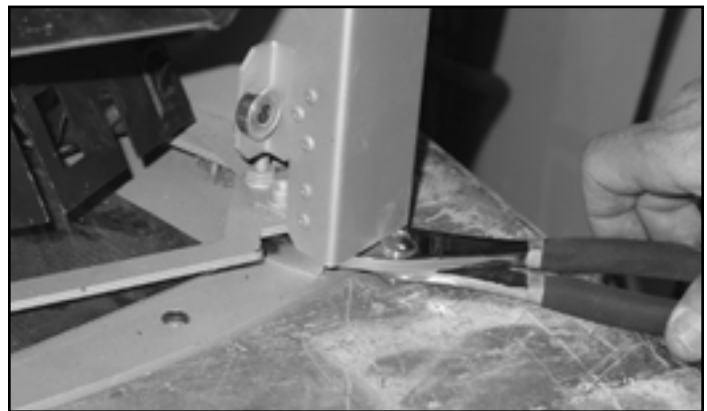





Figure 8.6

Using pliers, adjust the counters crews to level the appliance.

### D. Accessories

Install approved accessories per instructions included with accessories. See Service Parts List for appropriate accessories. Refer to **Section 12**.

 <b>WARNING</b>	
 	<p><b>Shock or fire risk.</b></p> <p>Use <b>ONLY</b> optional accessories approved for this appliance.</p> <ul style="list-style-type: none"> <li>• Using non-listed accessories voids warranty.</li> <li>• Using non-listed accessories may result in a safety hazard.</li> <li>• Only Hearth &amp; Home Technologies approved accessories may be used safely.</li> </ul>



## E. Top to Rear Vent Conversion

**Kit Contents:** Top cover (no hole); Back panel (with hole).

**Tools Required:** Power drill; #2 Phillips bit; 5/32 in. (4 mm) Allen wrench; 5/8 in. (16 mm) open end wrench; high-temp silicone sealant (optional).

1. Remove the front door assembly by lifting it off of the spring-loaded latches on top of the appliance. Remove the inner glass door by disengaging the spring-loaded latches at the bottom of the appliance and lifting it off of the two spring loaded latches at the top of the appliance.
2. Remove the top plate with hole and discard. (Figure 8.7).



Figure 8.7

3. Remove and retain the Allen head screws that hold the solid back panel in place. (Figure 8.8) Remove and discard the solid back panel.

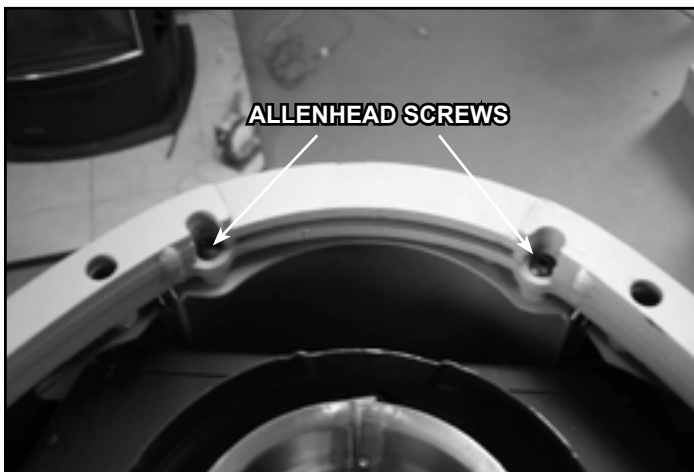


Figure 8.8

4. Remove the four screws from the DV adapter collar. (Figure 8.9) Set aside DV adapter collar, gasket and screws.
5. Remove the inner extension starter collar (Shown in Figure 8.9) and set aside.

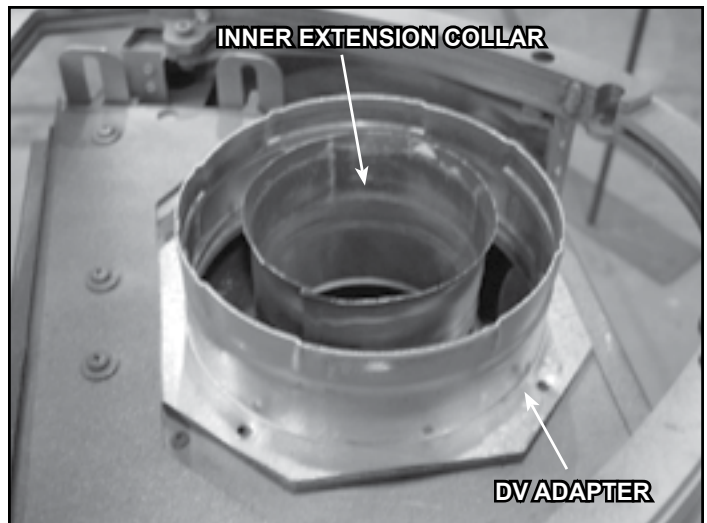


Figure 8.9

6. Remove the four screws from the cover plate on rear of appliance. Retain cover plate, gasket and screws. (see Figure 8.10).



Figure 8.10

7. Install the outer collar with gasket to the rear of appliance with screws previously removed. Install the inner extension starter collar. (Figure 8.11).
8. Install the new back panel (with hole) to the rear of appliance. Replace the allen head screws removed in Step 3 to hold the back panel in place. (Figure 8.11).



Figure 8.11

9. Install the cover plate and gasket removed from the rear of the appliance to the top of the appliance with the screws previously removed. (Figure 8.12).
10. Install the new solid top.

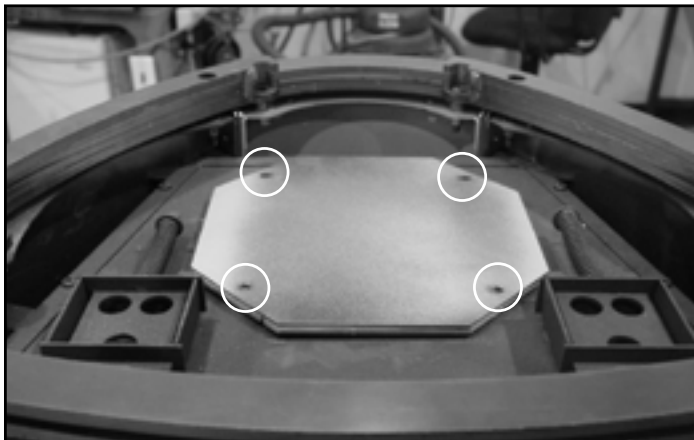


Figure 8.12

### F. Shutter Adjustment

The shutter is located on the underside of the burner, on the burner neck (see Figure 8.13).

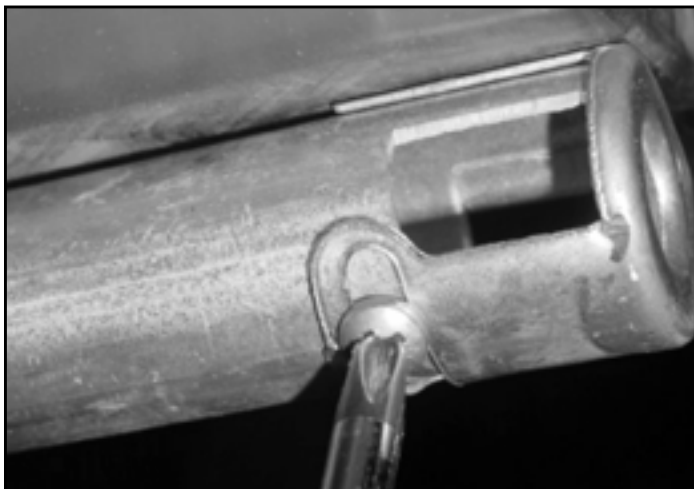


Figure 8.13

#### Air Shutter Settings

PALOMA-BZ-MOD PALOMA-BK-MOD PALOMA-GY MOD	NG	LP
Rear Vent	1/2 in.	1/2 in.
Top Vent	3/8 in.	1/2 in.

### G. Installing the Vent Restrictor

The vent restrictor plate must be installed before installing the baffle.

On the top of inside firebox for top vent ,on back of firebox for rear vent, loosen the three screws out about 1/8 in.

Place the vent restrictor plate over the screws and slide into locking position. Retighten the screws. (See Figure 8.15.)

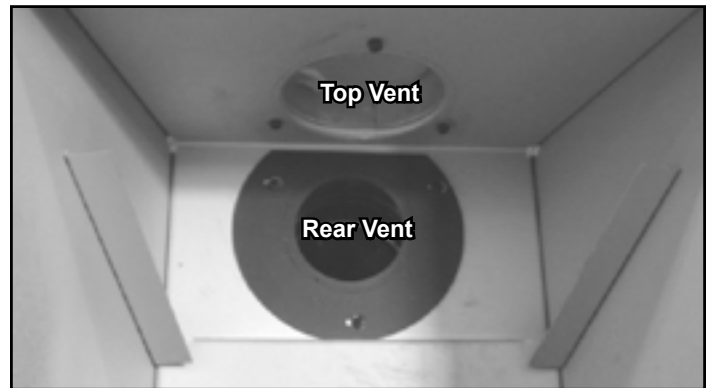


Figure 8.15

For vertical venting above 15 ft. a vent restrictor is required.

## H. Installing Rock Media and Ember Material

**CAUTION! Risk of Cuts or Abrasions.** Wear protective gloves and safety glasses during installation.

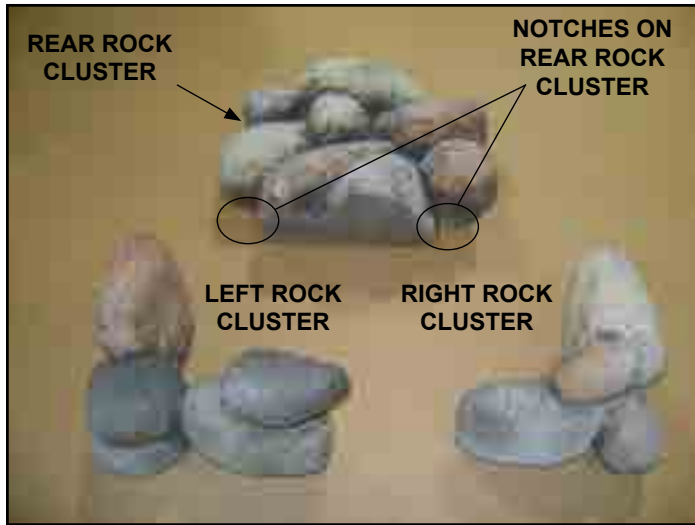




Figure 1. Rock Kit Components

### KIT CONTENTS

- (1) Rear Rock Cluster
- (1) Left Rock Cluster
- (1) Right Rock Cluster
- (1 ) Bag Ember Material

 <b>WARNING</b>	
	Delayed Ignition Risk
	<ul style="list-style-type: none"><li>• Place rock clusters according to instructions.</li><li>• Do NOT place rock clusters in a position that they cover burner ports.</li><li>• Do NOT use any media other than the rock clusters supplied with this fireplace.</li></ul>
	Fireplace will not function properly.
	Delayed ignition may occur.

## INSTALLATION

1. Place the rear rock cluster in the firebox as shown in Figure 2. The flat portion should fit tight against the back of the firebox. Slide cluster to the right. There are notches on the bottom of the rock cluster that should fit over the base pan. Cluster should rest on burner and base pan.

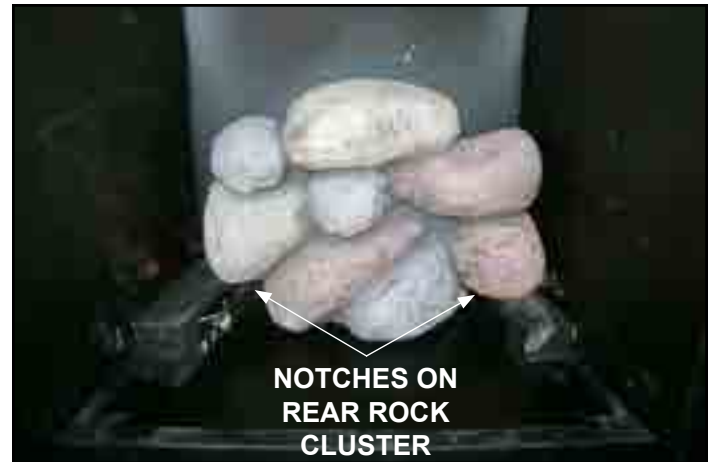


Figure 2. Placing Rear Rock Cluster

2. Place right rock cluster in firebox as shown in Figure 3. The right end of the cluster should touch the right wall of the firebox. Push cluster back until the rear and right rock clusters touch as shown in Figure 4. Ensure the rock clusters are not covering any burner ports.



Figure 3. Placing Right Rock Cluster



Figure 4. Right and Rear Rock Clusters Make Contact

3. Place left rock cluster in firebox as shown in Figure 5. The left end of the cluster should touch the left wall of the firebox. Push cluster back until the rear and left rock clusters contact each other as shown in Figure 6. Ensure the rock clusters are not covering any burner ports.

**WARNING! Risk of Explosion!** Follow instructions for placing rock clusters. DO NOT allow rock cluster to cover burner ports. Improperly placed rock cluster will interfere with proper burner operation.



Figure 5. Placing Left Rock Cluster

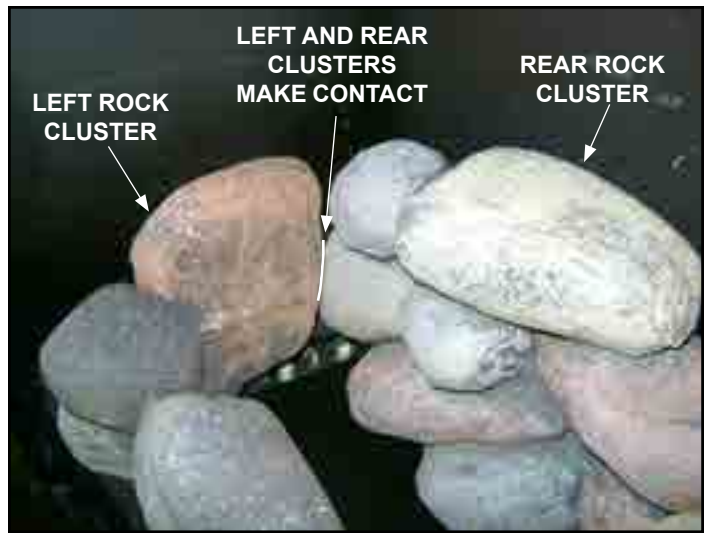


Figure 6. Left and Rear Rock Clusters Make Contact

4. Ember material is shipped with this kit. To place the ember material:

**WARNING! Risk of Explosion!** Follow ember placement instructions. DO NOT place embers directly over burner ports. Replace ember material annually. Improperly placed embers interfere with proper burner operation.

- Embers CANNOT be placed directly over ports. Care should be taken not to cover the lighting trail of ports (from back to front).
- Place dime-size pieces of embers in the areas highlighted in Figure 7. Care should be taken so that the ports are not covered. Failure to follow this procedure will likely cause lighting and sooting problems.

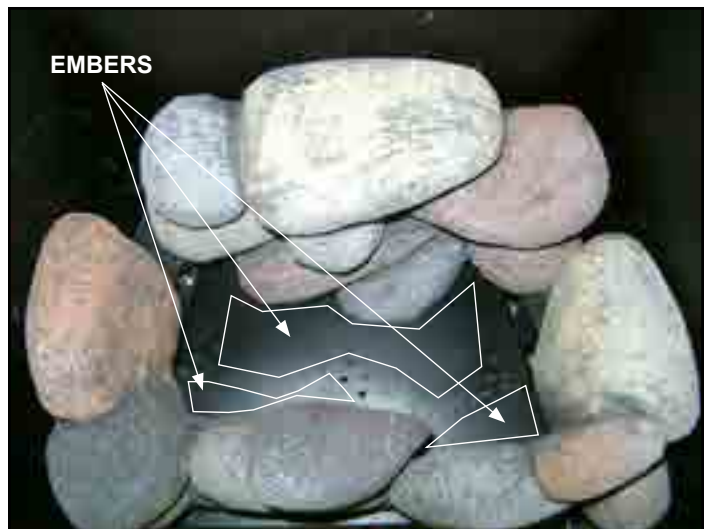


Figure 7. Ember Placement

## I. Optional Blower

The GFK-160A Blower has been designed to circulate room air through the appliance to enhance heat output.

The GFK-160A blower system operates on 120 VAC, 60 Hz power. This is available through a receptacle in the factory installed junction box. The junction box is mounted in the bottom of the appliance behind the access panel. A variable speed control is provided with the blower system to provide quiet forced air flow at the desired speeds. A temperature sensor switch, which automatically turns the blower ON/OFF, is also provided with this kit.

Compare contents of carton with the actual parts received. If any parts are missing or damaged, contact your dealer before starting installation. Do not install a damaged blower kit. See Figure 8.21.

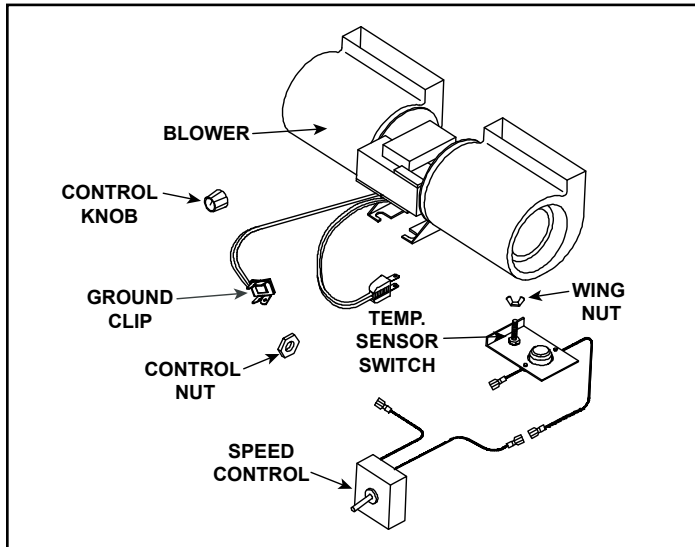


Figure 8.21

### Installation precautions

The GFK-160A Blower kit is tested and safe when installed in accordance with this installation manual. It is your responsibility to read all instructions before starting installation and to follow these instructions carefully during installation to assure maximum benefit from, and safe operation, of the blower.

This blower is carefully engineered and must be installed only as specified. If you modify it or any of its components, you may cause a fire hazard and will void the WARRANTY. In addition, such action may void the coverage provided by the owner's home insurance.

## CAUTION

All wiring should be done by a qualified electrician and shall be in compliance with local codes and with the National Electric Code ANSI/NFPA NO. 70-current (in the United States), or with the current CSA C22.1 Canadian Electric Code (in Canada).

## WARNING



**Shock Risk**

**Explosion Risk**

Do NOT wire 110-120 VAC to gas control valve.

Do NOT wire 110-120 VAC to wall switch.



- Incorrect wiring will damage millivolt valves.

- Incorrect wiring will override IPI safety lockout and may cause explosion.

Disconnect all electrical power. Remove the front door assembly by lifting off of appliance. Remove the lower access door. See Figure 8.22.



Figure 8.22

Attach enclosed wires to the temperature sensor switch/bracket assembly. The blue wire attaches to the rear of the bracket and one of the black wires from the variable speed control attaches closest to the prepunched screw hole. See Figure 8.23.



Figure 8.23

Feed the blue wire and other black wire from the variable speed control behind the gas valve assembly. Insert the wires into the slots indicated in Figure 8.28.

Locate the machine screw underneath the firebox on the right side. Position the temperature sensor switch/bracket assembly over the machine screw and attach with the wing nut. Finger tighten. See Figure 8.24.

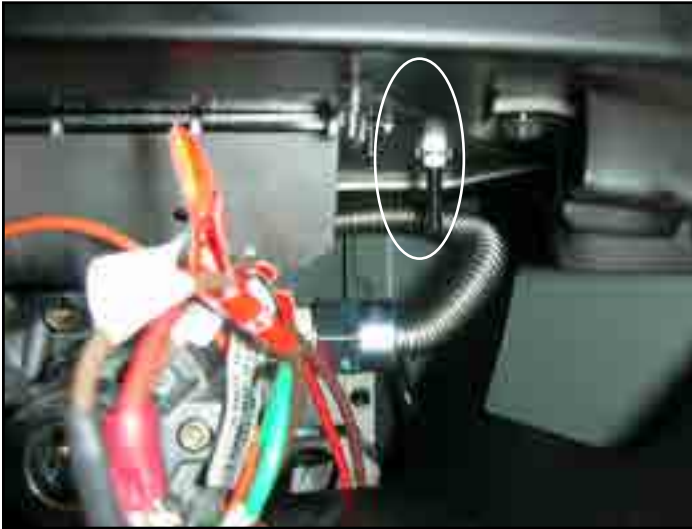


Figure 8.24

**Note:** The switch/bracket assembly must be installed so that the sensor switch makes contact with the bottom of the firebox.

Attach rheostat in mating feature of control shield so that orientation of control knob is downward. See Figure 8.25.

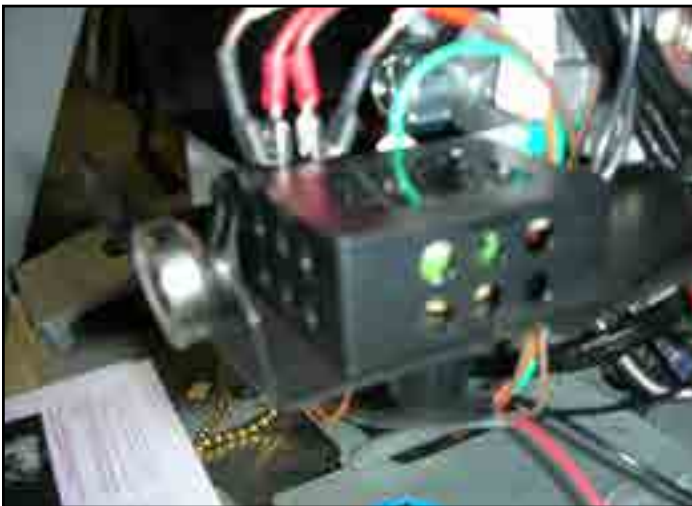


Figure 8.25

Attach the ground clip to the control panel. Attach the ground wire extension to the ground clip. Attach the blower ground wire to the ground wire extension. Refer to Figure 8.26.

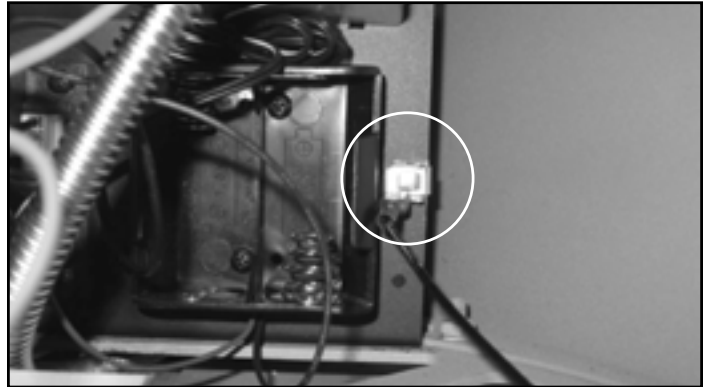


Figure 8.26

Plug the blower cord into the FAN outlet on the junction box. Push excess wires neatly towards the rear of the appliance.

Slide the blower into the bracket as indicated in Figure 8.27. Ensure the blower is pushed back into the bracket to allow the replacement of the lower access door. The magnet strips located on the blower feet are designed to hold the blower in place.

Plug appliance in. Turn the 110-120 VAC service "ON" at the circuit breaker and turn the speed control switch to the "ON" position.



Figure 8.27

## Recommended operating procedures

Ignite the fire in the appliance with the variable speed control switch in an "ON" position. The fan will automatically turn on when the temperature sensor switch closes at approximately 110 degrees Fahrenheit. Heated air should be delivered at the outlet grille. The fan will continue to operate after the appliance is turned OFF until the sensor switch opens.

Various conditions (such as appliance model, type of appliance installation, outside air temperature vs. inside air temperature) can contribute to the length of the time the blower remains on after the appliance is turned OFF. The blower can be turned off manually with the speed control switch.

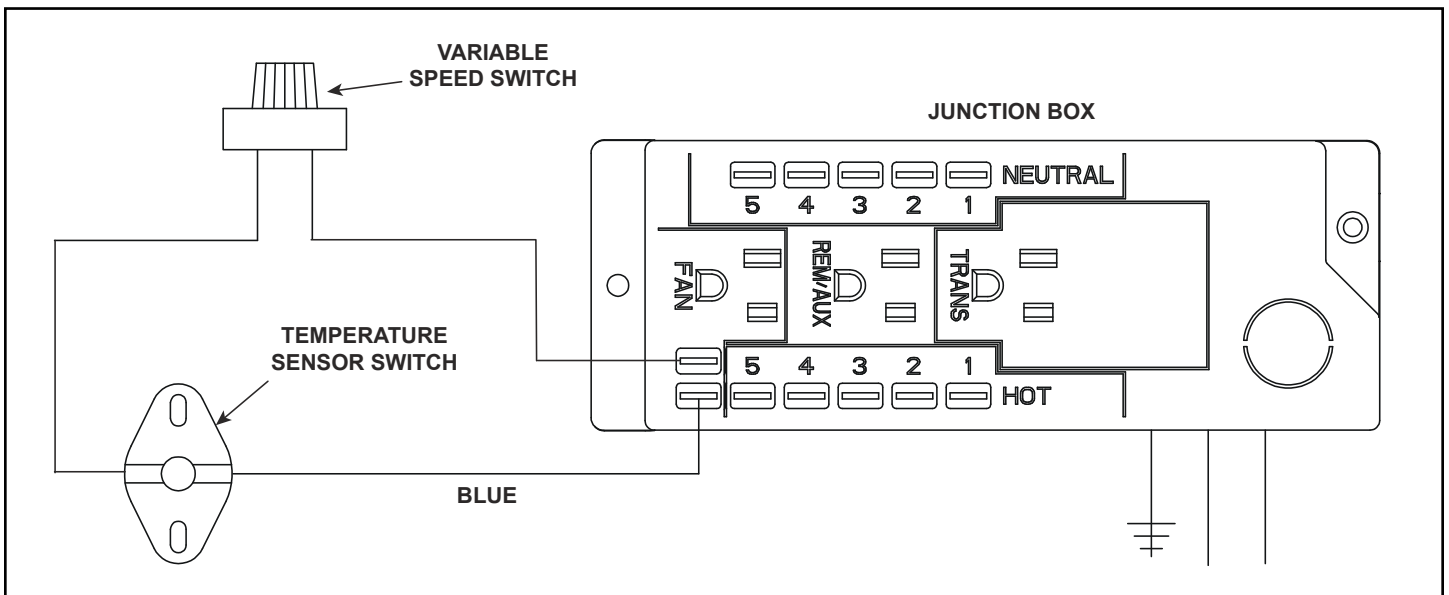


Figure 8.28 Blower Wiring Diagram

**WARNING! Risk of Shock!** Replace damaged wire with type 105° C rated wire. Wire must have high temperature insulation.

## J. Remote Controls

**Tools Required:** Powered screwdriver with Phillips head bit; hex wrench; 7/16 in. wrench; manometer.

Disconnect electricity at the circuit breaker before beginning this installation.

Familiarize yourself with the instructions enclosed with the remote control kit.

### Remote receiver

Remove the top plate from the appliance. Remove the Allen head screws attaching the back panel to the appliance. Retain screws.

Remove the front glass door assembly and the lower access door.

Using two wire ties from the appliance component bag, mount the remote receiver to the rear of the control panel.

Feed the red and orange wires to the front of the appliance. Remove the optional blower, if installed.

Plug the 3-prong remote receiver cord into the junction box (REM/AUX). Refer to Figure 8.29.

Plug the 2-prong blower cord directly into the 3-prong polarized plug on the back of the receiver. This receptacle output is 110/120 VAC, 3 AMP.

Attach the ground wire from the blower onto the grounding clip.

Attach red wires from the remote receiver to the ON/OFF switch.

Reinstall the blower into the blower bracket.

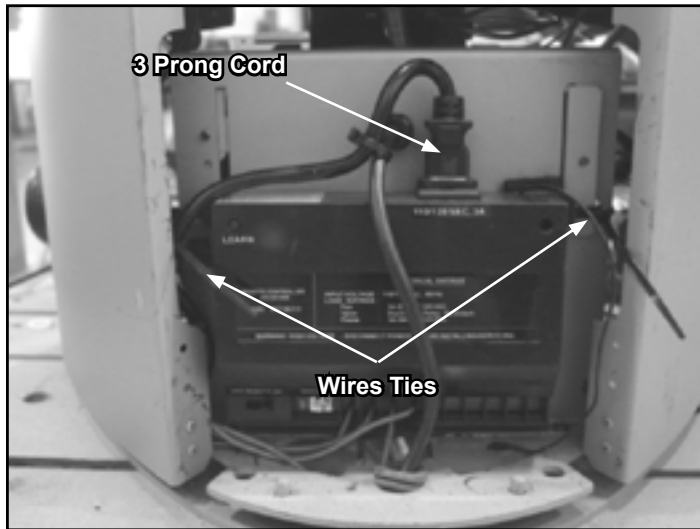


Figure 8.29

## Installing flame control solenoid

Remove the screw and knob from the variable regulator and discard. Unscrew the nut from the regulator and discard.

Remove the bag containing a washer and blue and red plungers from the side of the flame control solenoid.

Place washer on flame control solenoid. Insert the correct plunger (blue - Natural Gas, red - LP) into the flame control solenoid.

Thread the flame control solenoid with the correct plunger into the thread hole in the variable regulator. Turn one to two turns only. **DO NOT** tighten or damage may occur. See Figure 8.30.

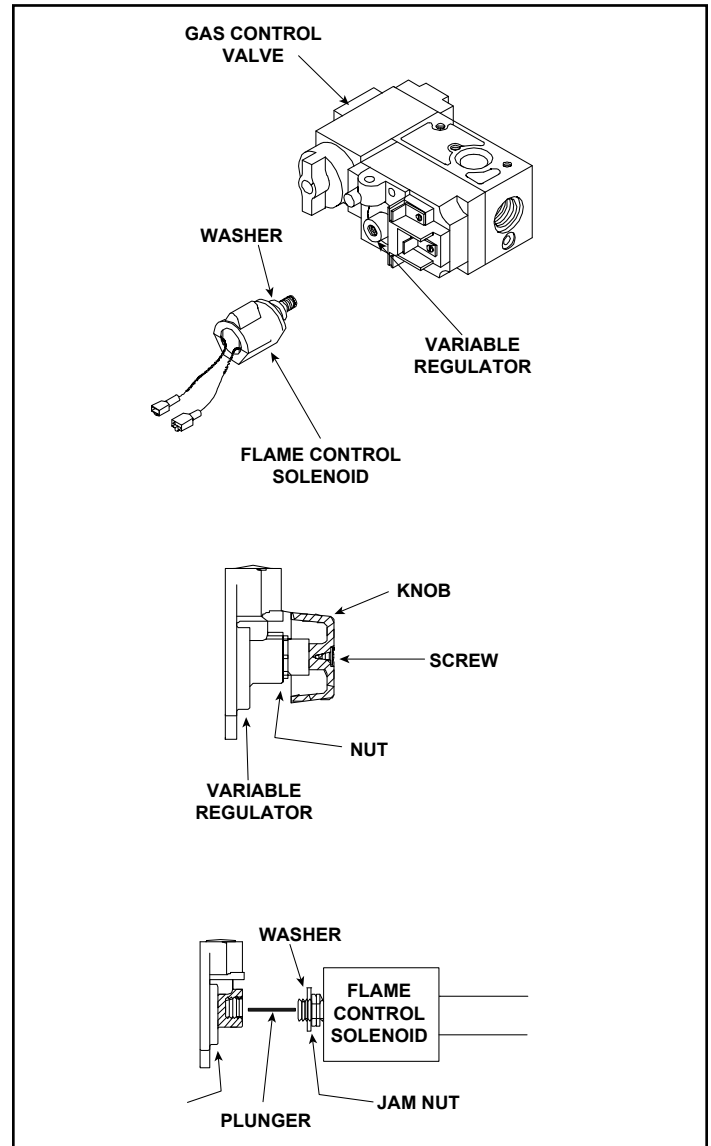


Figure 8.30 Flame Control Solenoid



**Wiring the flame control solenoid:**

Connect the two leads from the flame control solenoid to the orange leads from the receiver. See Figure 8.31.

Install a manometer into the pressure tap. Plug the remote receiver into the 110-120 VAC power supply.

Light the appliance as directed in Section 9 of this manual. Set the manifold pressure on the gas valve by rotating the flame control solenoid. Adjust until the reading on the manometer is 3.5 in. W.C. for natural gas or 10 in. W.C. for LP.

Tighten the jam nut to the face of the variable regulator body. See Figure 8.30. Turn the main gas knob on the gas valve OFF. Remove the manometer from the pressure tap and screw the tap closed.

Follow the instructions from the remote control kit to operate and program the remote control.

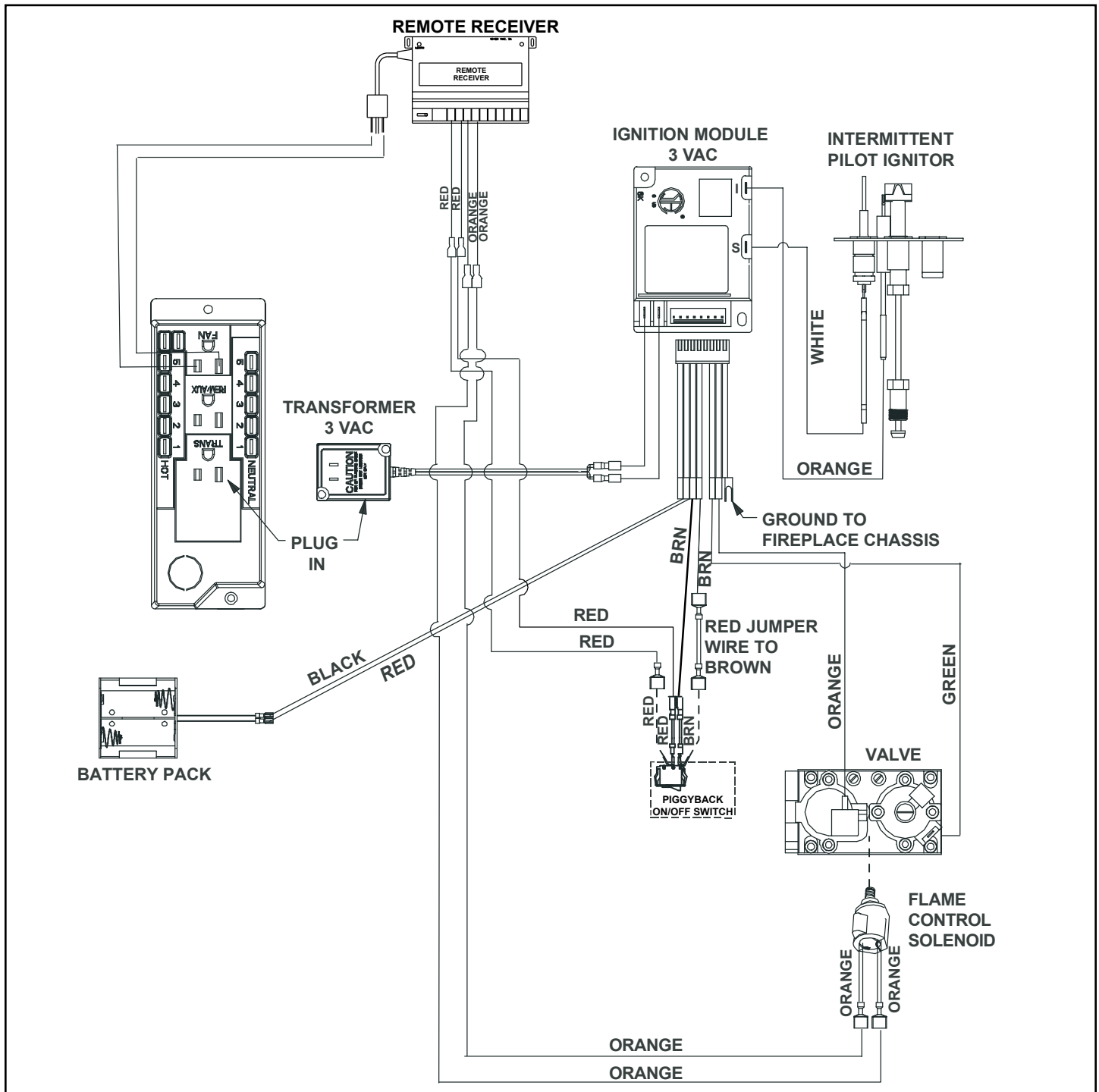


Figure 8.31 Remote Control IPI Wiring Diagram

## K. Front Door Glass Assembly Replacement

Remove the front door assembly by pulling bottom of front away from appliance and lifting it off of the spring-loaded latches on top of the appliance. See Figure 8.32.

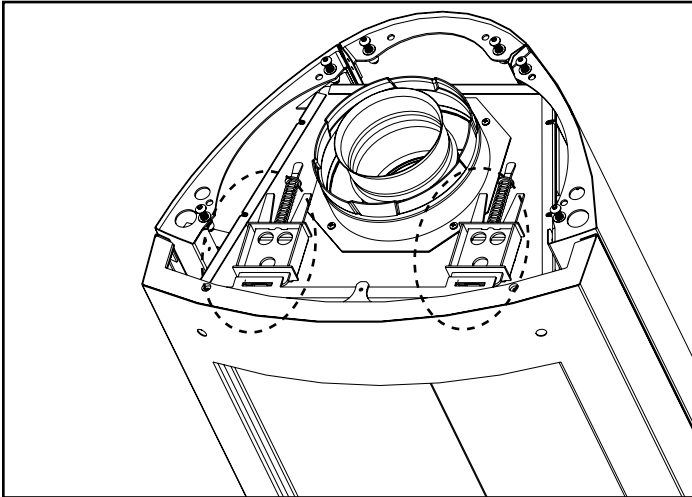


Figure 8.32

Position the four flat 1/4 in. (6 mm) spacer washers on the front door so that the four mounting screws pass through them. Position the glass over the front door.

Install the four protective barrels into the glass and the four nylon washers on top of the glass.

From inside the door front, pass the screws through to the outside and thread on the caps until tight. See Figure 8.33.

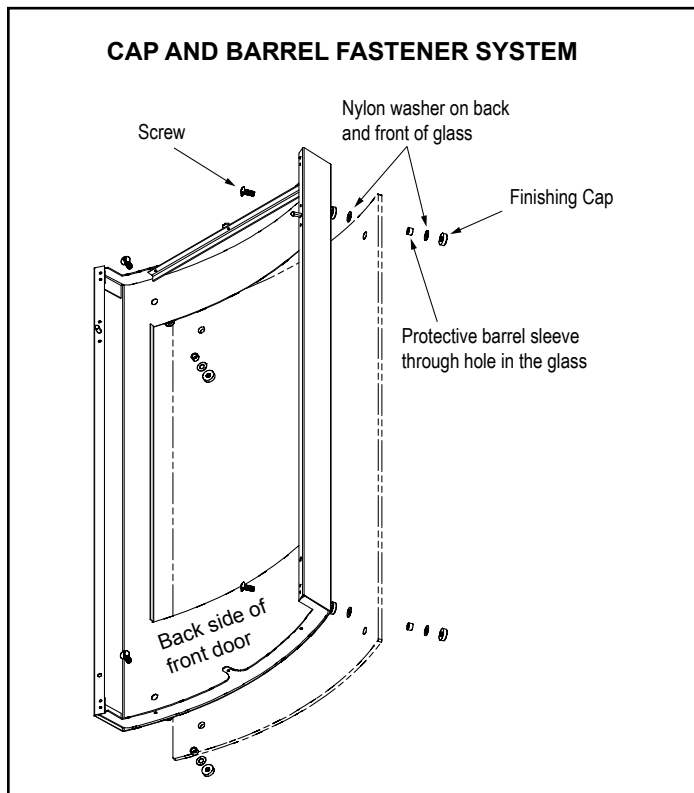


Figure 8.33

## L. Inner Glass Door Assembly Replacement

Turn the appliance OFF and let it cool down before replacing the inner glass door assembly.

With the front door assembly removed from the appliance, remove the inner glass door assembly by disengaging the spring-loaded latches at the bottom of the appliance and lifting off of the two spring-loaded latches at the top of the appliance.

Replace with a new inner glass door assembly.

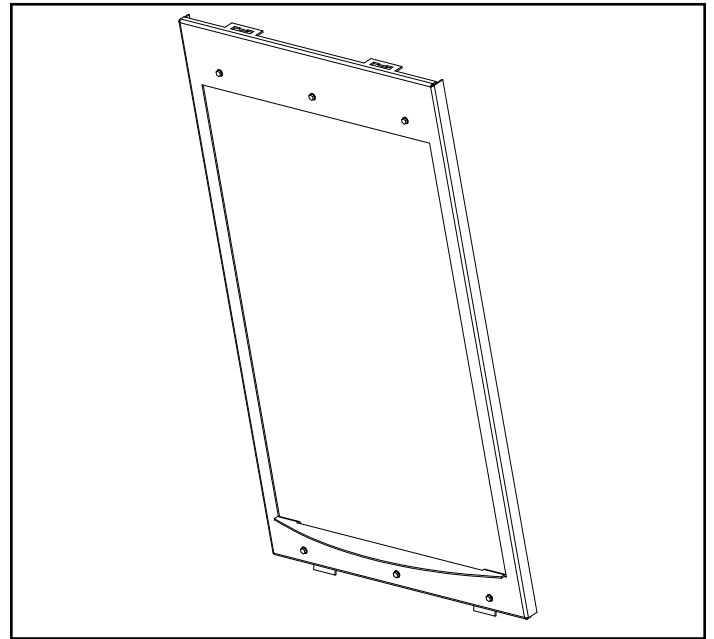


Figure 8.34 Complete Assembly

**WARNING! Risk of Asphyxiation!** Handle glass door assembly with care. Inspect the gasket to ensure it is undamaged and inspect the glass for cracks, chips or scratches.

- **DO NOT** strike, slam or scratch glass.
- **DO NOT** operate fireplace with glass removed, cracked, broken or scratched.
- Replace glass door as a complete assembly.

# 9 Operating Instructions

## A. Before Lighting Appliance

Read this entire manual prior to using the appliance. Failure to follow the instructions may result in property damage, bodily injury, or even death.

### CAUTION

If installing IntelliFire ignition battery backup:

- Do not install batteries if the backup mode may not be used for extended time.
- Batteries may leak.
- Install batteries only when needed for power outage.

### Before operating this appliance have a qualified technician:

- Remove all shipping materials from inside and/or underneath the firebox.
- Review proper placement of logs and mineral wool.
- Check the wiring.
- Check the baffle adjustment.
- Ensure that there are no gas leaks.
- Ensure that the glass is sealed and in the proper position.
- Ensure that the flow of combustion and ventilation air is not obstructed (front grilles and vent caps).

### WARNING



Glass door must be in place when appliance is operating.

#### Risk of:

- Combustion Fumes
- Fire



Do NOT operate appliance with glass door removed.

- Open viewing glass for servicing only.

- Glass door MUST be in place and sealed before operating appliance.
- Only use glass door certified for use with appliance.
- Glass replacement should be done by qualified technician.

### WARNING

Improper installation, adjustment, alteration, service or maintenance can cause injury or property damage. Refer to the owner's information manual provided with this appliance. For assistance or additional information consult a qualified installer, service agency or the gas supplier.

### WARNING



#### HOT SURFACES!

Glass and other surfaces are hot during operation AND cool down.

#### Hot glass will cause burns.

- Do not touch glass until it is cooled
- NEVER allow children to touch glass
- Keep children away
- CAREFULLY SUPERVISE children in same room as fireplace.
- Alert children and adults to hazards of high temperatures.

#### High temperatures may ignite clothing or other flammable materials.

- Keep clothing, furniture, draperies and other flammable materials away.

**WARNING! Risk of Fire, Explosion or Electric Shock! DO NOT use this appliance if any part has been under water. Call a qualified service technician to inspect the appliance and to replace any part of the control system and/or gas control which has been under water.**

## B. Controls

**On/off Switch:** When this switch is in the ON position, the pilot ignitor is engaged until temperature is established. The burner automatically turns on.

**Valve Variable Control:** This knob controls the flame height from low ("LO") to high ("HI"). The indicator on the valve indicates the position of the knob.

**Variable Speed Control:** The blower is optional installed on the appliance and this knob controls the speed of the blower that pushes the heated air into the room.

**Note:** If using a remote control wall switch, or thermostat, the On/Off Switch must be left "OFF". Turning the On/Off Switch to "ON" will keep the appliance on continually.

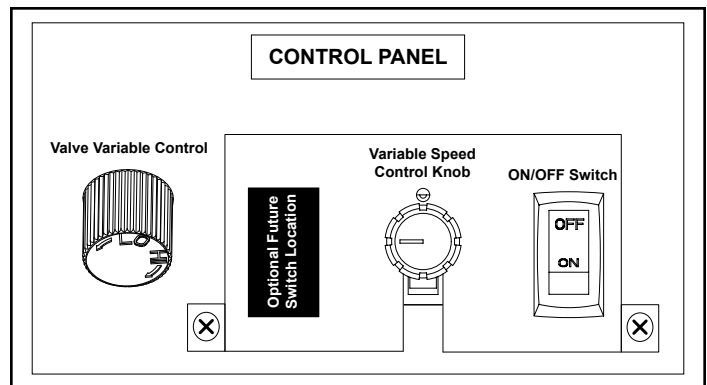


Figure 9.1

## C. Lighting Instructions (IPI)

The IPI system may be operated with two D-cell batteries. When using batteries, unplug the transformer. To prolong battery life, remove them when using the transformer.

### FOR YOUR SAFETY READ BEFORE LIGHTING

**WARNING:** If you do not follow these instructions exactly, a fire or explosion may result causing property damage, personal injury or loss of life.

- A.** This appliance is equipped with an intermittent pilot ignition (IPI) device which automatically lights the burner. **DO NOT** try to light the burner by hand.
- B. BEFORE LIGHTING,** smell all around the appliance area for gas. Be sure to smell next to the floor because some gas is heavier than air and will settle on the floor.
- WHAT TO DO IF YOU SMELL GAS**
- **DO NOT** try to light any appliance.
  - **DO NOT** touch any electric switch; do not use any phone in your building.
- Immediately call your gas supplier from a neighbor's phone. Follow the gas supplier's instructions.
  - If you cannot reach your gas supplier, call the fire department.
- C. DO NOT** use this appliance if any part has been under water. Immediately call a qualified service technician to inspect the appliance and to replace any part of the control system and any gas control which has been under water.

### WARNING:

**DO NOT CONNECT LINE VOLTAGE (110/120 VAC OR 220/240 VAC) TO THE CONTROL VALVE.**

Improper installation, adjustment, alteration, service or maintenance can cause injury or property damage. Refer to the owner's information manual provided with this appliance.

This appliance needs fresh air for safe operation and must be installed so there are provisions for adequate combustion and ventilation air.

If not installed, operated, and maintained in accordance with the manufacturer's instructions, this product could expose you to substances in fuel or fuel combustion which are known to the State of California to cause cancer, birth defects, or other reproductive harm.

Keep burner and control compartment clean. See installation and operating instructions accompanying appliance.

For additional information on operating your  
Hearth & Home Technologies fireplace, please refer to [www.fireplaces.com](http://www.fireplaces.com).

### CAUTION:

Hot while in operation. **DO NOT** touch. Keep children, clothing, furniture, gasoline and other liquids having flammable vapors away.

**DO NOT** operate the appliance with fixed glass assembly removed, cracked or broken. Replacement of the fixed glass assembly should be done by a licensed or qualified service person.

### NOT FOR USE WITH SOLID FUEL

For use with natural gas and propane. A conversion kit, as supplied by the manufacturer, shall be used to convert this appliance to the alternate fuel.

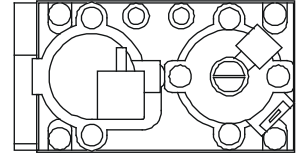
**Also Certified for Installation in a Bedroom or a Bedsitting Room.**

For assistance or additional information, consult a qualified installer, service agency or the gas supplier.

### LIGHTING INSTRUCTIONS (IPI)

1. This appliance is equipped with an ignition device which automatically lights the burner. **DO NOT** try to light the burner by hand.

**GAS  
VALVE**



2. Wait five (5) minutes to clear out any gas. Then smell for gas, including near the floor. If you smell gas, **STOP!** Follow "B" in the Safety Information located on the left side of this label. If you do not smell gas, go to next step.
3. To light the burner:  
  
Equipped with wall switch: Turn ON/OFF switch to ON.  
  
Equipped with remote or wall control: Press ON or FLAME button.  
  
Equipped with thermostat: Set temperature to desired setting.
4. If the appliance does not light after three tries, call your service technician or gas supplier.

### TO TURN OFF GAS TO APPLIANCE

1. Equipped with wall switch: Turn ON/OFF switch to OFF.  
  
Equipped with remote or wall control: Press OFF button.  
  
Equipped with thermostat: Set temperature to lowest setting.
2. Service technician should turn off electric power to the control when performing service.

593-913G

**Final inspection by** \_\_\_\_\_



## D. After Appliance is Lit


### Initial Break-in Procedure


When you light the appliance, you may notice that it produces heat which does have an associated odor or smell. If you feel this odor is excessive it may require the initial three to four hour continuous burn on high followed by a second burn up to 12 hours to fully drive off any odor from paint and lubricants used in the manufacturing process. Condensation of the glass is normal.



**NOTE:** The appliance should be run three to four hours on the initial start-up. Turn it off and let it cool completely. Remove and clean the glass. Replace the glass and run the appliance for an additional 12 hours. This will help to cure the products used in the paint and logs.

During this break-in period it is recommended that some windows in the house be opened for air circulation. This will help avoid setting off smoke detectors, and help eliminate any odors associated with the appliance's initial burning.

 <b>WARNING</b>	
	<p><b>Fire Risk.</b> High Temperatures. Keep combustible household items away from appliance. Do NOT obstruct combustion and ventilation air.</p> <ul style="list-style-type: none"> <li>• Do NOT place combustible items on top of or in front of appliance.</li> <li>• Keep furniture, draperies away from appliance.</li> </ul>

 <b>CAUTION</b>	
<ul style="list-style-type: none"> <li>• Prevent accidental appliance operation when not attended.</li> <li>• Unplug or remove batteries from remote control if absent or if appliance will not be used for an extended period of time.</li> <li>• Property damage possible from elevated temperatures.</li> </ul>	

 <b>CAUTION</b>	
Smoke and odors released during initial operation.	
<ul style="list-style-type: none"> <li>• Open windows for air circulation.</li> <li>• Leave room during initial operation.</li> <li>• Smoke may set off smoke detectors.</li> </ul>	
Smoke and odors may be irritating to sensitive individuals.	

 <b>WARNING</b>	
	<p><b>Fire Hazard.</b> Keep combustible materials, gasoline and other flammable vapors and liquids clear of appliance.</p> <ul style="list-style-type: none"> <li>• Do NOT store flammable materials in the appliance's vicinity.</li> <li>• Do NOT use gasoline, lantern fuel, kerosene, charcoal lighter fluid or similar liquids in this appliance.</li> <li>• Combustible materials may ignite.</li> </ul>

## E. Frequently Asked Questions

ISSUE	SOLUTIONS
Condensation on the glass	This is a result of gas combustion and temperature variations. As the fireplace warms, this condensation will disappear.
Blue flames	This is a result of normal operation and the flames will begin to yellow as the fireplace is allowed to burn for 20 to 40 minutes.
Odor from fireplace	When first operated, this fireplace may release an odor for the first several hours. This is caused by the curing of the paint and the burning off of any oils remaining from manufacturing. Odor may also be released from finishing materials and adhesives used around the fireplace.
Film on the glass	This is a normal result of the curing process of the paint. Glass should be cleaned within 3 to 4 hours of initial burning to remove deposits left by oils from the manufacturing process. A non-abrasive cleaner such as gas fireplace glass cleaner may be necessary. See your dealer.
Metallic noise	Noise is caused by metal expanding and contracting as it heats up and cools down, similar to the sound produced by a furnace or heating duct. This noise does not affect the operation or longevity of the fireplace.
Is it normal to see the pilot flame burn continually?	In an intermittent pilot ignition system (IPI), the pilot flame should turn off when appliance is turned off. Some optional control systems available with IPI models may allow pilot flame to remain lit. In a standing pilot system the pilot will always stay on.

# 10 Troubleshooting

With proper installation, operation, and maintenance your gas appliance will provide years of trouble-free service. If you do experience a problem, this troubleshooting guide will assist a qualified service technician in the diagnosis of a problem and the corrective action to be taken. This troubleshooting guide can only be used by a qualified service technician. Contact your dealer to arrange a service call by a qualified service technician.

## A. IntelliFire Ignition System

Symptom	Possible Cause	Corrective Action
1. Pilot won't light. The ignitor/module makes noise, but no spark.	A. Incorrect wiring.	Verify "S" wire (white) for sensor and "I" wire (orange) for ignitor are connected to correct terminals on module and pilot assembly.
	B. Loose connections or electrical shorts in the wiring.	Verify no loose connections or electrical shorts in wiring from module to pilot assembly. Verify connections underneath pilot assembly are tight; also verify connections are not grounding out to metal chassis, pilot burner, pilot enclosure, mesh screen if present, or any other metal object.
	C. Ignitor gap is too large.	Verify gap of igniter to right side of pilot hood. The gap should be approximately .17 in. or 1/8 in. (3 mm).
	D. Module.	Turn ON/OFF rocker switch or wall switch to OFF position. Remove ignitor wire "I" from module. Place a grounded wire about 3/16 in. (5 mm) away from "I" terminal on module. Place ON/OFF rocker switch or wall switch in ON position. If there is no spark at "I" terminal module must be replaced. If there is a spark at "I" terminal, module is fine. Inspect pilot assembly for shorted sparker wire or cracked insulator around electrode. Replace pilot if necessary.
2. Pilot won't light, there is no noise or spark.	A. No power or transformer installed incorrectly.	Verify that transformer is installed and plugged into module. Check voltage of transformer under load at spade connection on module with ON/OFF switch in ON position. Acceptable readings of a good transformer are between 3.2 and 2.8 volts AC.
	B. A shorted or loose connection in wiring configuration or wiring harness.	Remove and reinstall the wiring harness that plugs into module. Verify there is a tight fit. Verify pilot assembly wiring to module. Remove and verify continuity of each wire in wiring harness. Replace any damaged components.
	C. Improper wall switch wiring.	Verify that 110-120 VAC power is "ON" to junction box.
	D. Module not grounded.	Verify black ground wire from module wire harness is grounded to metal chassis of appliance.
	E. Module.	Turn ON/OFF rocker switch or wall switch to OFF position. Remove ignitor wire "I" from module. Place ON/OFF rocker switch or wall switch in ON position. If there is no spark at "I" terminal module must be replaced. If there is a spark at "I" terminal, module is fine. Inspect pilot assembly for shorted sparker wire or cracked insulator around electrode.
3. Pilot sparks, but Pilot will not light.	A. Gas supply.	Verify that incoming gas line ball valve is "open". Verify that inlet pressure reading is within acceptable limits, inlet pressure must not exceed 14 in. W.C.
	B. Ignitor gap is too large.	Verify gap of igniter to right side of pilot hood. The gap should be approximately .17 in. or 1/8 in. (3 mm).
	C. Module is not grounded.	Verify module is securely grounded to metal chassis of appliance.
	D. Module voltage output / Valve/Pilot solenoid ohms readings.	Verify battery voltage is at least 2.7 volts. Replace batteries if voltage is below 2.7.

## IntelliFire Ignition System - (continued)

Symptom	Possible Cause	Corrective Action
<p>4. Pilot lights but continues to spark, and main burner will not ignite. (If the pilot continues to spark after the pilot flame has been lit, flame rectification has not occurred.)</p>	<p>A. A shorted or loose connection in flame sensing rod.</p>	<p>Verify all connections to wiring diagram in manual. Verify connections underneath pilot assembly are tight. Verify connections are not grounding out to metal chassis, pilot burner, pilot enclosure or screen if present, or any other metal object.</p>
	<p>B. Poor flame rectification or contaminated flame sensing rod.</p>	<p>With fixed glass assembly in place, verify that flame is engulfing flame sensing rod on left side of pilot hood. Flame sensing rod should glow shortly after ignition. Verify correct pilot orifice is installed and gas inlet is set to pressure specifications. Polish flame sensing rod with fine steel wool to remove any contaminants that may have accumulated on flame sensing rod.</p>
	<p>C. Module is not grounded.</p>	<p>Verify module is securely grounded to metal chassis of appliance. Verify that wire harness is firmly connected to the module.</p>
	<p>D. Damaged pilot assembly or contaminated flame sensing rod.</p>	<p>Verify that ceramic insulator around the flame sensing rod is not cracked, damaged, or loose. Verify connection from flame sensing rod to white sensor wire. Polish flame sensing rod with fine steel wool to remove any contaminants that may have accumulated on flame sensing rod. Verify continuity with a multimeter with ohms set at lowest range. Replace pilot if any damage is detected.</p>
	<p>E. Module.</p>	<p>Turn ON/OFF rocker switch or wall switch to OFF position. Remove ignitor wire "I" from module. Place ON/OFF rocker switch or wall switch in ON position. If there is no spark at "I" terminal module must be replaced. If there is a spark at "I" terminal, module is fine.</p>

# 11 Maintaining and Servicing Appliance

Although the frequency of appliance servicing and maintenance will depend on use and the type of installation, a qualified service technician should perform an appliance checkup at the beginning of each heating season.

## WARNING

Risk of injury or property damage.

### Before servicing:

- Turn off gas.
- Turn off electricity to appliance.
- Disable remote control, if one is present.
- Ensure appliance is completely cooled.

### After servicing:

- Replace any screen or barrier that was removed.
- Reseal and reinstall any venting removed for servicing.

## WARNING



Annual inspection by qualified technician recommended.

### Check:

- Condition of glass, glass assembly and glass seal.
- Obstructions of combustion and ventilation air.
- Burner ignition and operation.
- Burner air shutter adjustment
- Gas connections and fittings.
- Obstructions of termination cap.

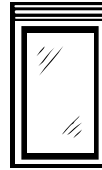
### Clean:

- Glass
- Air passageways, grilles, control compartment
- Burner, burner ports

### Risk of:

- Fire
- Delayed ignition or explosion
- Exposure to combustion fumes
- Odors

## CAUTION



Handle glass assembly with care.

**NOTE:** Clean glass after initial 3-4 hours operation. **Longer operation without cleaning glass may cause a permanent white film on glass.**

### When cleaning glass door:

- Avoid striking, scratching or slamming glass.
- Do NOT use abrasive cleaners.
- Use a hard water deposit glass cleaner on white film.
- Do NOT clean glass when hot.
- Turn off appliance after 3-4 hours of operation and **ALLOW TO COOL.**
- Remove and clean glass assembly.
- Replace glass assembly and operate appliance for additional 12 hours.

Refer to maintenance instructions.

## WARNING



Inspect external vent cap regularly.

- Ensure no debris blocks cap.
- Combustible materials blocking cap may ignite.
- Restricted air flow affects burner operation.





## A. Maintenance Tasks

Inspect	Maintenance Tasks
	<ol style="list-style-type: none"> <li>1. Inspect for scratches, dents or other damage and repair as necessary.</li> <li>2. Verify no obstructions to airflow through the louvers.</li> <li>3. Verify maintenance of proper clearance to combustible household objects.</li> </ol>
Gasket Seal, Glass Assembly and Glass	<ol style="list-style-type: none"> <li>1. Inspect gasket seal and its condition.</li> <li>2. Inspect glass panels for scratches and nicks that can lead to breakage when exposed to heat.</li> <li>3. Confirm there is no damage to glass or glass frame. Replace as necessary.</li> <li>4. Verify that latches engage properly, clip studs are not stripped, and glass attachment components are intact and operating properly. Replace as necessary.</li> <li>5. Clean glass. Replace glass assembly if severely coated with silicate deposits that cannot be removed.</li> </ol>
Valve Compartment and Firebox Top	<ol style="list-style-type: none"> <li>1. Vacuum and wipe out dust, cobwebs, debris or pet hair. Use caution when cleaning these areas. Screw tips that have penetrated the sheet metal are sharp and should be avoided.</li> <li>2. Remove any foreign objects.</li> <li>3. Verify unobstructed air circulation.</li> </ol>
Rocks	<ol style="list-style-type: none"> <li>1. Inspect for broken, damaged, or missing rocks. Replace as necessary.</li> <li>2. Verify correct rock placement and no flame impingement causing sooting. Correct as necessary.</li> </ol>
Firebox	<ol style="list-style-type: none"> <li>1. Inspect for paint condition, warpage, corrosion or perforation. Sand and repaint as necessary.</li> <li>2. Replace appliance if firebox has been perforated.</li> </ol>
Burner Ignition and Operation	<ol style="list-style-type: none"> <li>1. Verify burner is properly secured and aligned with pilot or igniter.</li> <li>2. Clean off burner top, inspect for plugged ports, corrosion or deterioration. Replace burner if necessary.</li> <li>3. Replace ember materials with new dime-size and shape pieces. Do not block ports or obstruct lighting paths.</li> <li>4. Check for smooth lighting and ignition carryover to all ports. Verify there is no ignition delay.</li> <li>5. Inspect for lifting or other flame problems.</li> <li>6. Inspect orifice for soot, dirt or corrosion.</li> <li>7. Verify manifold and inlet pressures. Adjust regulator as required.</li> <li>8. Inspect pilot flame strength. Clean or replace orifice as necessary.</li> <li>9. Inspect thermocouple/thermopile or IPI sensor rod for soot, corrosion and deterioration. Polish with fine steel wool or replace as required.</li> <li>10. Verify millivolt output. Replace as necessary.</li> </ol>
Venting	<ol style="list-style-type: none"> <li>1. Inspect venting for blockage or obstruction such as bird nests, leaves, etc.</li> <li>2. Confirm that termination cap remains clear and unobstructed by plants, etc.</li> <li>3. Verify that termination cap clearance to subsequent construction (building additions, decks, fences or sheds) has been maintained.</li> <li>4. Inspect for corrosion or separation.</li> <li>5. Verify weather stripping, sealing and flashing remains intact.</li> </ol>
Remote controls	<ol style="list-style-type: none"> <li>1. Verify operation of remote.</li> <li>2. Replace batteries in remote transmitters and battery-powered receivers.</li> </ol>

# 12 Reference Materials

## A. Appliance Dimension Diagram

Dimensions are actual appliance dimensions. Use for reference only. For framing dimensions and clearances refer to Section 3.

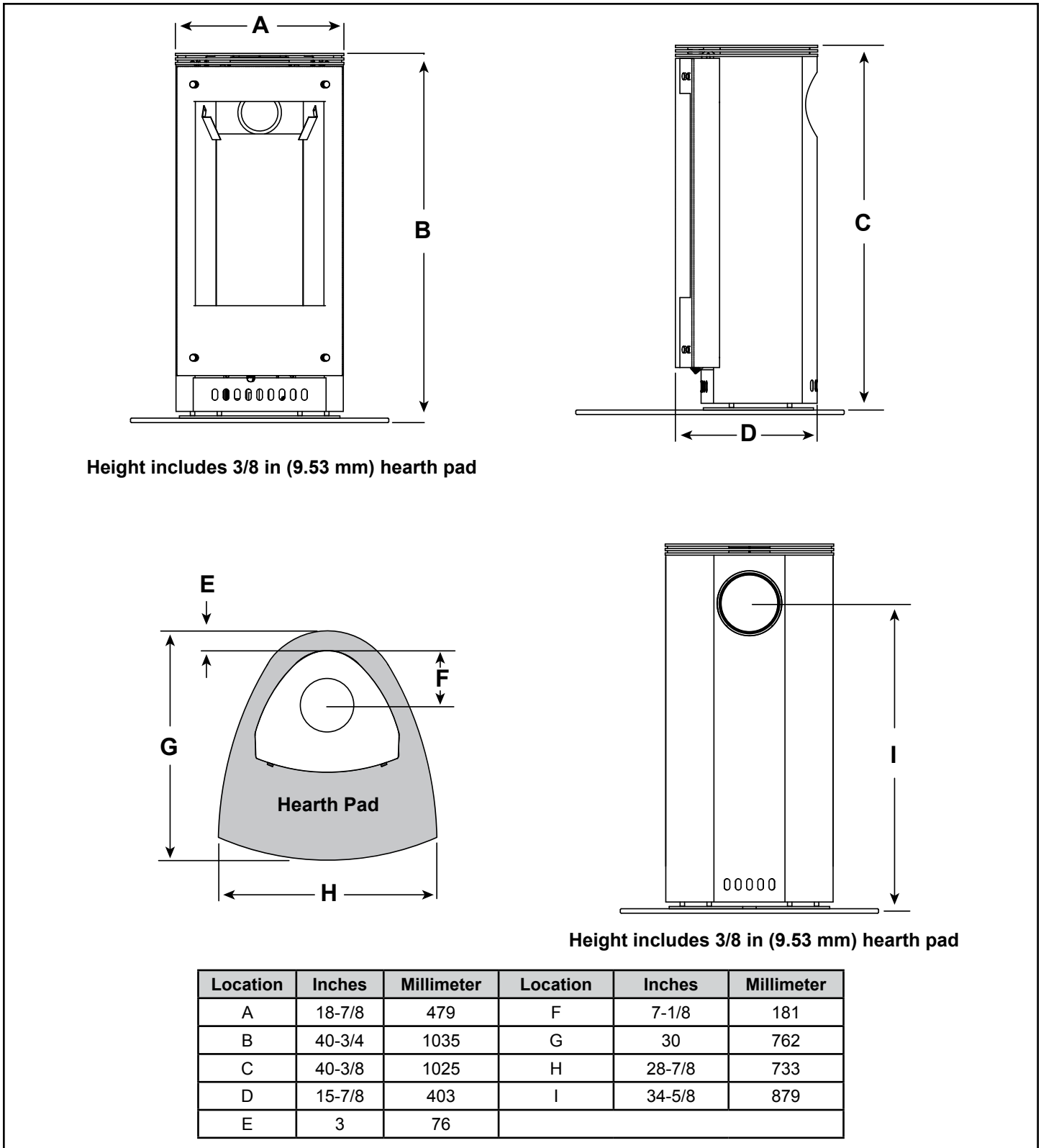


Figure 12.1 Appliance Dimensions

## B. Vent Components Diagram

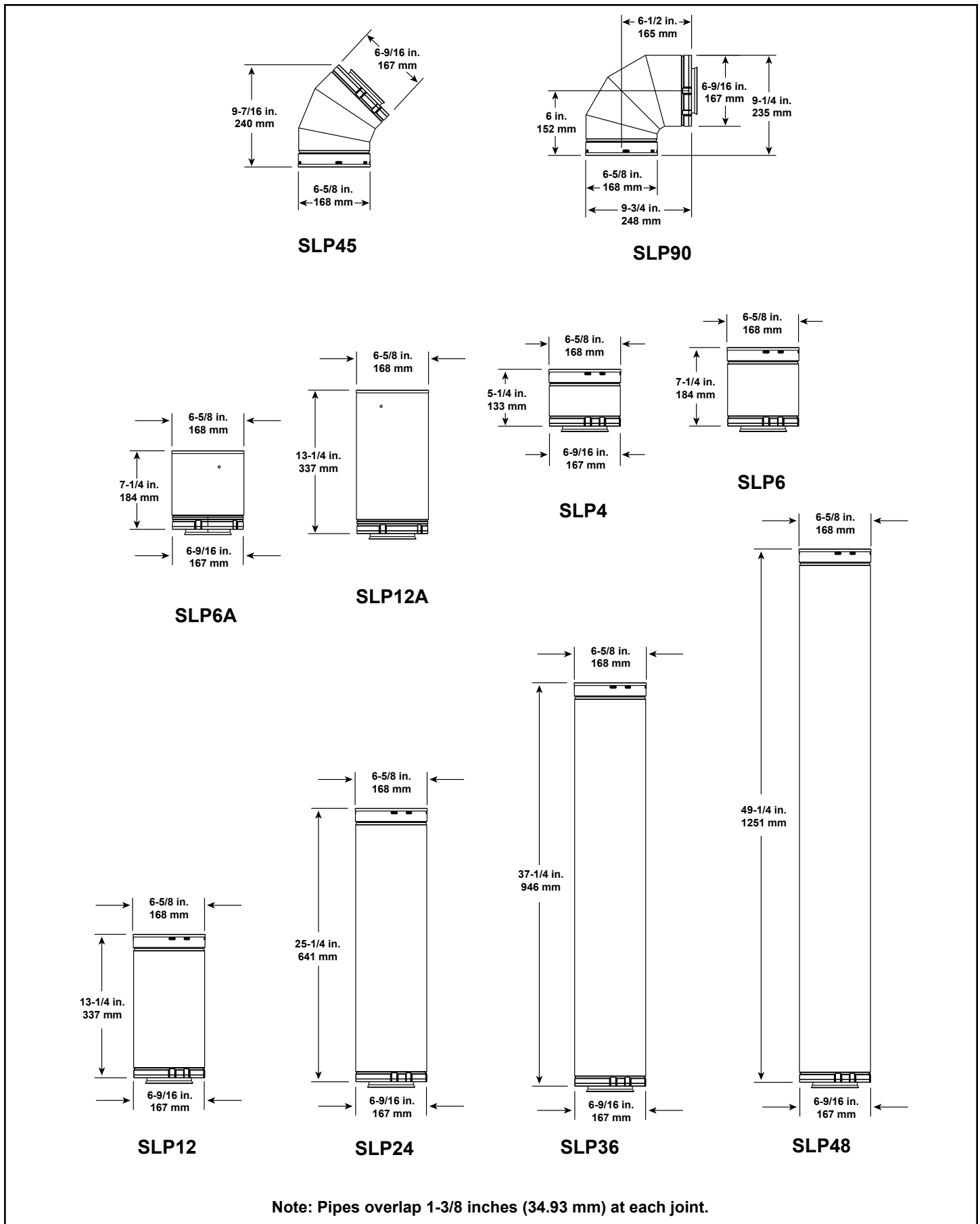


Figure 12.3 SLP Series Vent Components

→ D. Vent Components Diagrams (continued)

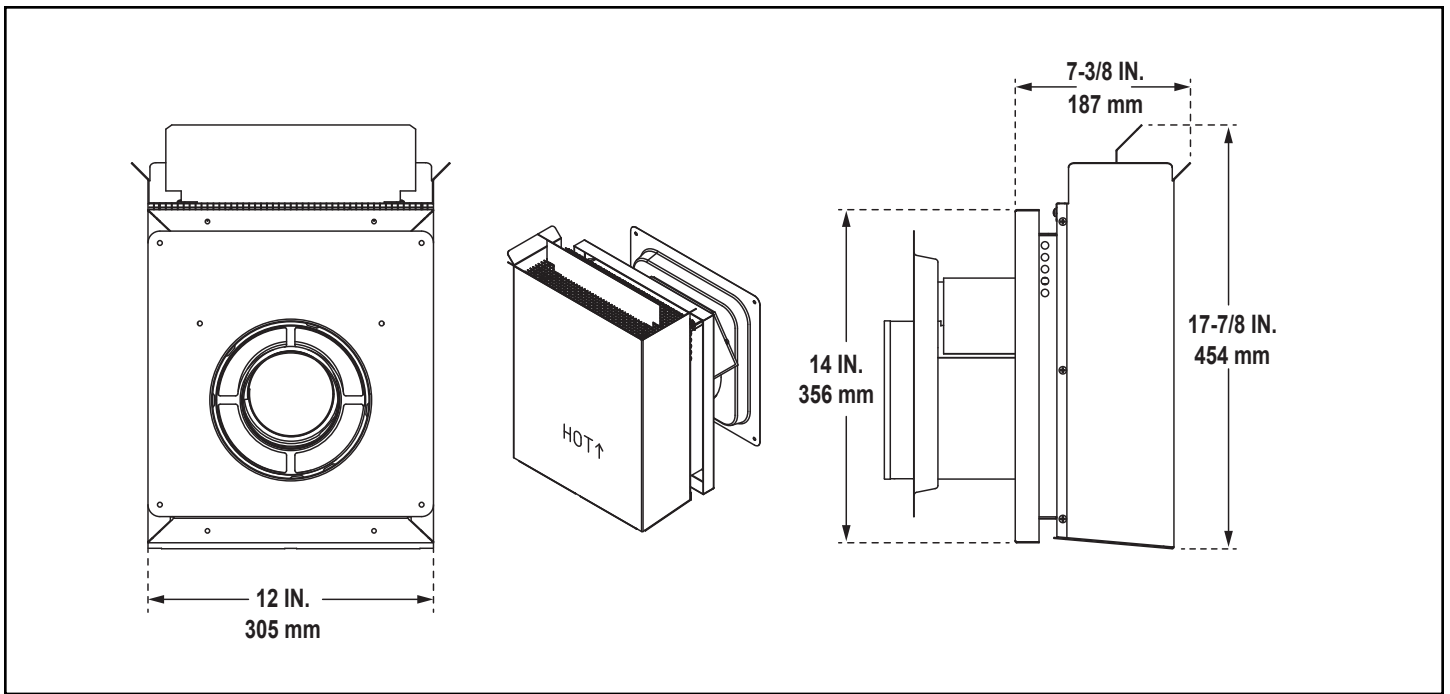


Figure 12.4 SLP Series Vent Components

## C. Vent Components List

COMPONENTS	
SLP-WT-BK	Ceiling Support / Wall Thimble, Black
SLP-CCS-BK	Cathedral Ceiling Support, Black
SLP6-BK	6 inch Pipe Length, Black
SLP4-BK	9 inch Pipe Length, Black
SLP12-BK	12 inch Pipe Length, Black
SLP34-BK	24 inch Pipe Length, Black
SLP36-BK	36 inch Pipe Length, Black
SLP48-BK	48 inch Pipe Length, Black
SLP6A-BK	11 inch - 14-5/8 inch Pipe Length, Black
SLP12A-BK	12 inch - 17 inch Pipe, Adjustable, Black
SLP45-BK	45 degree Elbow, Black
SLP90-BK	90 degree Elbow, Black
SLP4	4 inch Pipe
SLP6	6 inch Pipe
SLP12	12 inch Pipe
SLP24	24 inch Pipe
SLP36	36 inch Pipe
SLP48	48 inch Pipe
SLP45	45 degree Elbow
SLP90	90 degree Elbow
SLP6A	3-6 in. Adjustable Pipe Extension
SLP12A	3-12 in. Adjustable Pipe Extension
SLP-RF6	0/12 - 6/12 Roof Flashing
SLP-RF12	7/12 - 12/12 Roof Flashing
SL-SCD	Storm Collar
SLP-FS	Ceiling Firestop
SLP-WS	Wall Firestop
SLP-HVS	Pipe Support Hanger
950	Vinyl Protector Kit - SL Pipe
DRC-RADIUS	Decorative Radius Cover
SLP-SA	Flue Adaptor

TERMINATION KITS	
SLP-TRAP2	Trapezoid Termination Kit
SLP-TVHW	Vertical Termination Cap - High Wind
SRVSLK-991DA	Vertical Termination Cap
SLP-SK-BK	Horizontal Termination Kit (includes 904B, 930D, SLK-01TRD)
SLK-SNKD	Snorkel Kit
LINK-STOVE	Adapter Kit (includes 30 ft. of 4 inch flex, apapters, wall thimble, masonry & ZC flashing, 991DA cap and hardware package)
VPK-DV	Vinyl Siding Protector Kit
SLP-HHW2	HHW2 Horizontal High Wind Cap (recommended for optimal performance)
SLP-HRC-SS	SLP High Rise Cap-stainless steel
SLP-HRC-ZC-SS	SLP Zero Clearance High Rise Cap-stainless steel
899-4491	HHW2K Horizontal Kit (one 90 degree black wall thimble, 24 inch black pipe, 11 inch - 14-5/8 inch adjustable vent, HHW2 termination cap)
844-8921	RHVK Snorkel Kit (with Dura-Vent parts 911B and 940)
MISCELLANEOUS	
46DVA-SC	Storm Collar
46DVA-FS	Ceiling Firestop
46DVA-WS	Wall Strap
46DVA-IS	Attic Insulation Shield
46DVA-GK	Chimney Liner Termination Kit
46DVA-GCL	Co-axial / Co-lineal Appliance Connector
46DVA-KMC	Retrofit Adj. Chimney Connector Retrofit Chimney Connector Plate

**NOTICE: The PVK-80 power vent kit is NOT approved for use with PALOMA-BZ-MOD, PALOMA-BK-MOD, or PALOMA-GY-MOD.**

D. Service Parts



No one builds a better fire

Service Parts

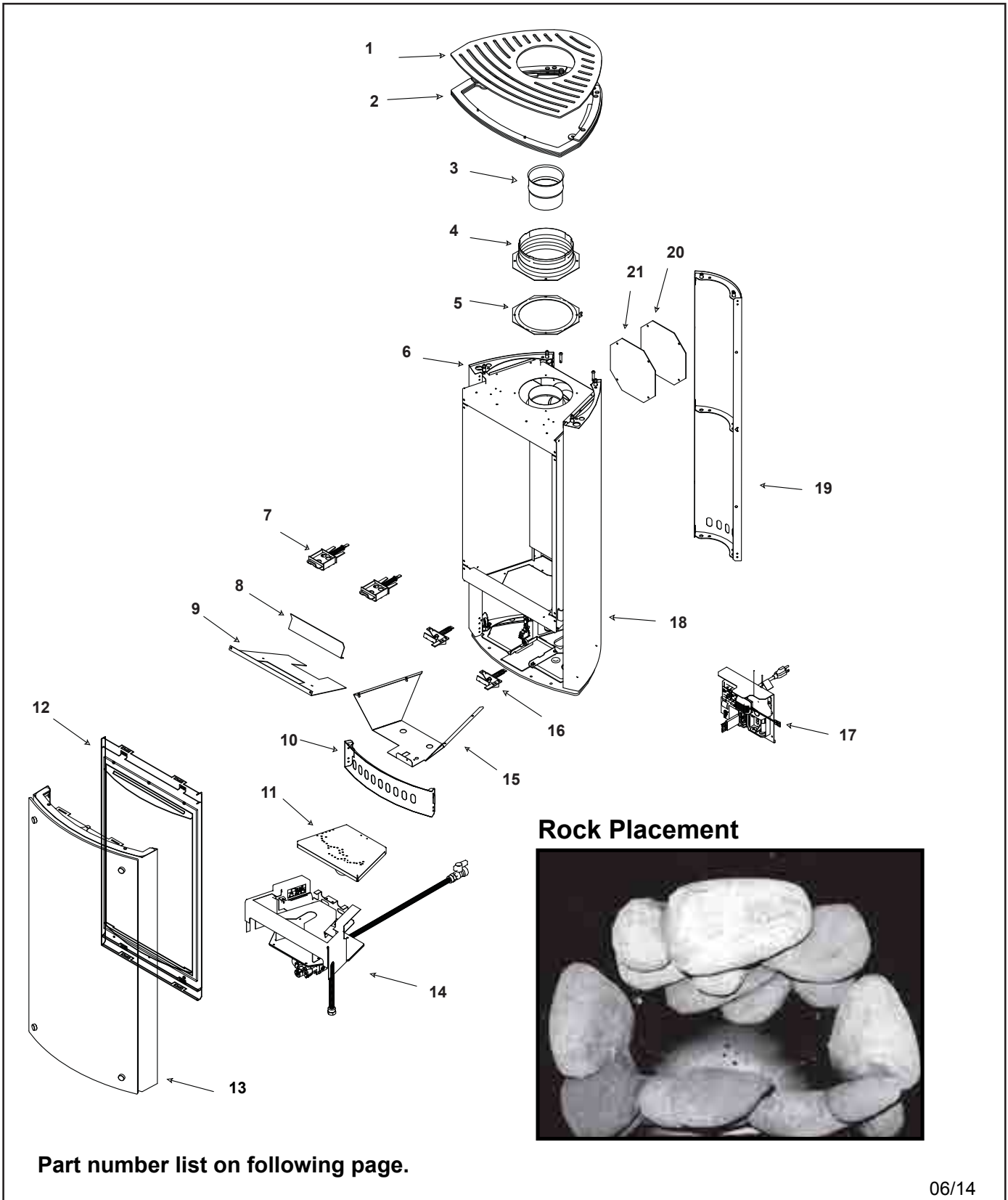
Gas Stove - DV

Paloma-GY-MOD (Gray), Paloma-GR-MOD (Green),  
Paloma-BZ-MOD (Bronze), Paloma-BK-MOD (Black)

PALOMA-MOD

Beginning Manufacturing Date: Aug 2009

Ending Manufacturing Date: Active



06/14

No one builds a better fire

Beginning Manufacturing Date: Aug 2009

Ending Manufacturing Date: Active

IMPORTANT: THIS IS DATED INFORMATION. Parts must be ordered from a dealer or distributor. **Hearth and Home Technologies does not sell directly to consumers.** Provide model number and serial number when requesting service parts from your dealer or distributor.



**Stocked  
at Depot**

ITEM	DESCRIPTION	COMMENTS	PART NUMBER	
	Rock Assembly		Paloma-Rock	
1	Removable Top Assembly Top Vent	Gray	2123-012	
		Black	2123-012-BK	
	Removable Top Assembly Rear Vent	Gray	2123-025	
		Black	2123-025-BK	
2	Top Assembly	Gray	7031-013	
		Black	7031-013-BK	
3	SLP Stove Adaptor		SLP-SA	
4	Starting Collar Assembly		2189-002	
5	Gasket, Adaptor		460-0610	
6	Side Assembly Left	Gray	2123-027	
		Black	2123-027-BK	
7	Latch Assembly Upper		7003-006	Y
8	Heat Shield Baffle		2189-106	
9	Heat Shield		2189-105	
10	Access Door Assembly	Gray	7031-023	
		Black	7031-023-BK	
11	Burner Assembly		2189-005	Y
12	Glass Frame Assembly		2189-004	Y
13	Front Door Assembly	Bronze	2123-028	
		Green	2123-029	
		Gray	2123-016	
		Black	2123-028-BK	
	Cap and Barrel Assembly	Gray	2123-019	
		Black	2143-030	
14	Valve Plate Assembly		2189-003	
15	Air Deflector		2123-185	
16	Latch Assembly Lower	Pkg of 2	33858/2	Y
17	Control Assembly		7031-027	Y
	Control Module		593-592	Y
	Junction Box		4021-013	Y
	Power Cord		832-2410	Y
	Wire Assembly		593-590A	Y
	3V Transformer		593-593A	Y
	Battery Pack		593-594A	Y
18	Side Assembly Right	Gray	2123-026	
		Black	2123-026-BK	

Additional service part numbers appear on following page.

No one builds a better fire

Beginning Manufacturing Date: Aug 2009

Ending Manufacturing Date: Active

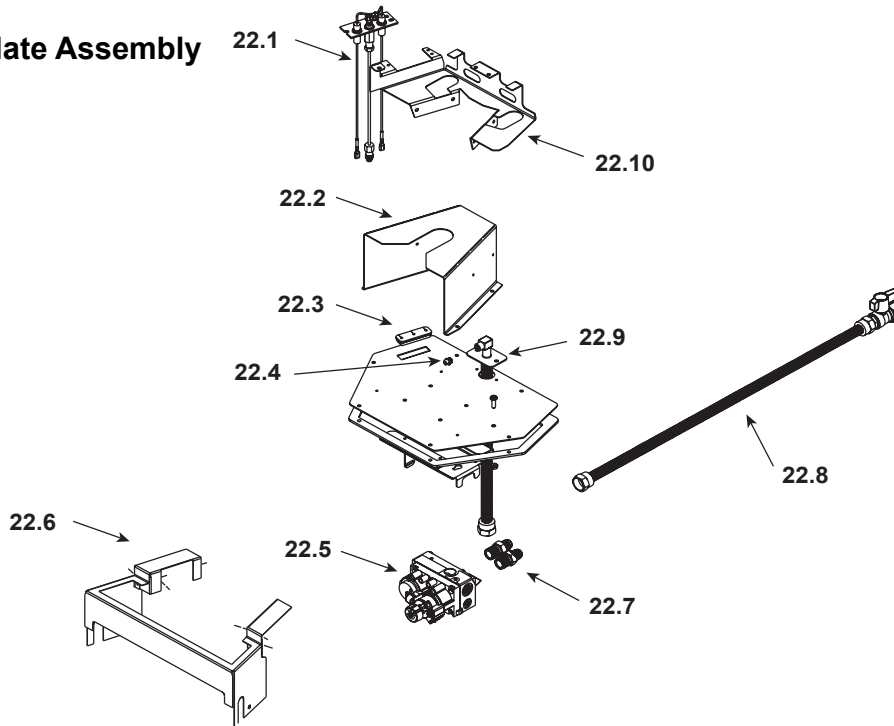
IMPORTANT: THIS IS DATED INFORMATION. Parts must be ordered from a dealer or distributor. **Hearth and Home Technologies does not sell directly to consumers.** Provide model number and serial number when requesting service parts from your dealer or distributor.



**Stocked  
at Depot**

ITEM	DESCRIPTION	COMMENTS	PART NUMBER	
19	Back Panel Assembly Vertical	Gray	7031-021	
		Black	7031-021-BK	
	Back Panel Assembly Horizontal		7031-022	
20	Cover Plate		2189-111	
21	Cover Plate Gasket		7010-160	

### #22 Bottom Plate Assembly



22	Bottom Plate Assembly	Gray	2123-015	
		Black	2123-015-BK	
22.1	Pilot Assembly NG		2090-012	Y
	Pilot Assembly LP		2090-013	Y
22.2	Burner Support		7031-279	
22.3	3-Hole Grommet		2118-420	
22.4	Orifice NG (#38C)		582-838	Y
	Orifice LP (#53C)		582-853	Y
22.5	Valve NG		750-500	Y
	Valve LP		750-501	Y
22.6	Burner Shelf		2189-113	
22.7	Male connector	Pkg of 5	303-315/5	Y
22.8	Flex Ball Valve Assembly		2098-034	Y
22.9	Flex 12"		383-302A	Y
22.10	Pilot Bracket		2189-119	

Additional service part numbers appear on following page.



No one builds a better fire

Beginning Manufacturing Date: Aug 2009

Ending Manufacturing Date: Active

IMPORTANT: THIS IS DATED INFORMATION. Parts must be ordered from a dealer or distributor. **Hearth and Home Technologies does not sell directly to consumers.** Provide model number and serial number when requesting service parts from your dealer or distributor.



**Stocked  
at Depot**

ITEM	DESCRIPTION	COMMENTS	PART NUMBER	
	Flue Collar		7018-117	
	Flue Restrictor Plate		2189-118	
	<b>Magnet Bracket Assembly</b>		<b>7031-028</b>	
	Switch On/Off Rocker		230-0730	Y
	Temp Sensor		107-531	Y
	Variable Speed Control		100-510A	Y
	Conversion Kit NG		NGK-PALOMA-MOD	Y
	Conversion Kit LP		LPK-PALOMA-MOD	Y
	Pilot Orifice NG		593-528	Y
	Pilot Orifice LP		593-527	Y
	Regulator NG		NGK-DXV	Y
	Regulator LP		LPK-DXV	Y
	Blower with Rheostat		GFK-160A	
	Remote Control		RCT-MLT-HNG	
	Wall Thermostat		WH-STAT	
	Wall Switch Kit (Off white)		WSK-21	
	Wall Switch Kit (White)		WSK-21-W	
	Rear Vent Conversion Kit		VRT-TR-AU	
		Black	VRT-TR-BK	
	Front Glass	Bronze	PAL-GLS-BZ	
		Green	PAL-GLS-GR	
		Smoke	PAL-GLS-GY	
	Standard Hearth Pad	Bronze	HP-PAL-BZ	
		<b>No longer available</b>	HP-PAL-GR	
		Smoke	HP-PAL-GY	
	Touch Up Paint (Pewter)		TUPNP-12	
	Touch Up Paint (Black)		TUP-GBK-12	

## E. Limited Lifetime Warranty

### Hearth & Home Technologies LIMITED LIFETIME WARRANTY

Hearth & Home Technologies, on behalf of its hearth brands ("HHT"), extends the following warranty for HHT gas, wood, pellet, coal and electric hearth appliances that are purchased from an HHT authorized dealer.

#### **WARRANTY COVERAGE:**

HHT warrants to the original owner of the HHT appliance at the site of installation, and to any transferee taking ownership of the appliance at the site of installation within two years following the date of original purchase, that the HHT appliance will be free from defects in materials and workmanship at the time of manufacture. After installation, if covered components manufactured by HHT are found to be defective in materials or workmanship during the applicable warranty period, HHT will, at its option, repair or replace the covered components. HHT, at its own discretion, may fully discharge all of its obligations under such warranties by replacing the product itself or refunding the verified purchase price of the product itself. The maximum amount recoverable under this warranty is limited to the purchase price of the product. This warranty is subject to conditions, exclusions and limitations as described below.

#### **WARRANTY PERIOD:**

Warranty coverage begins on the date of original purchase. In the case of new home construction, warranty coverage begins on the date of first occupancy of the dwelling or six months after the sale of the product by an independent, authorized HHT dealer/ distributor, whichever occurs earlier. The warranty shall commence no later than 24 months following the date of product shipment from HHT, regardless of the installation or occupancy date. The warranty period for parts and labor for covered components is produced in the following table.

The term "Limited Lifetime" in the table below is defined as: 20 years from the beginning date of warranty coverage for gas appliances, and 10 years from the beginning date of warranty coverage for wood, pellet, and coal appliances. These time periods reflect the minimum expected useful lives of the designated components under normal operating conditions.

Warranty Period		HHT Manufactured Appliances and Venting							Components Covered
Parts	Labor	Gas	Wood	Pellet	EPA Wood	Coal	Electric	Venting	
1 Year		X	X	X	X	X	X	X	All parts and material except as covered by Conditions, Exclusions, and Limitations listed
2 years				X	X	X			Igniters, electronic components, and glass
		X	X	X	X	X			Factory-installed blowers
			X						Molded refractory panels
3 years				X					Firepots and burnpots
5 years	1 year			X	X				Castings and baffles
7 years	3 years		X	X	X				Manifold tubes, HHT chimney and termination
10 years	1 year	X							Burners, logs and refractory
Limited Lifetime	3 years	X	X	X	X	X			Firebox and heat exchanger
90 Days		X	X	X	X	X	X	X	All replacement parts beyond warranty period

See conditions, exclusions, and limitations on next page.

## **E. Limited Lifetime Warranty (*continued*)**

### **WARRANTY CONDITIONS:**

- This warranty only covers HHT appliances that are purchased through an HHT authorized dealer or distributor. A list of HHT authorized dealers is available on the HHT branded websites.
- This warranty is only valid while the HHT appliance remains at the site of original installation.
- This warranty is only valid in the country in which the HHT authorized dealer or distributor that sold the appliance resides.
- Contact your installing dealer for warranty service. If the installing dealer is unable to provide necessary parts, contact the nearest HHT authorized dealer or supplier. Additional service fees may apply if you are seeking warranty service from a dealer other than the dealer from whom you originally purchased the product.
- Check with your dealer in advance for any costs to you when arranging a warranty call. Travel and shipping charges for parts are not covered by this warranty.

### **WARRANTY EXCLUSIONS:**

This warranty does not cover the following:

- Changes in surface finishes as a result of normal use. As a heating appliance, some changes in color of interior and exterior surface finishes may occur. This is not a flaw and is not covered under warranty.
- Damage to printed, plated, or enameled surfaces caused by fingerprints, accidents, misuse, scratches, melted items, or other external sources and residues left on the plated surfaces from the use of abrasive cleaners or polishes.
- Repair or replacement of parts that are subject to normal wear and tear during the warranty period. These parts include: paint, wood, pellet and coal gaskets, firebricks, grates, flame guides, batteries and the discoloration of glass.
- Minor expansion, contraction, or movement of certain parts causing noise. These conditions are normal and complaints related to this noise are not covered by this warranty.
- Damages resulting from: (1) failure to install, operate, or maintain the appliance in accordance with the installation instructions, operating instructions, and listing agent identification label furnished with the appliance; (2) failure to install the appliance in accordance with local building codes; (3) shipping or improper handling; (4) improper operation, abuse, misuse, continued operation with damaged, corroded or failed components, accident, or improperly/incorrectly performed repairs; (5) environmental conditions, inadequate ventilation, negative pressure, or drafting caused by tightly sealed constructions, insufficient make-up air supply, or handling devices such as exhaust fans or forced air furnaces or other such causes; (6) use of fuels other than those specified in the operating instructions; (7) installation or use of components not supplied with the appliance or any other components not expressly authorized and approved by HHT; (8) modification of the appliance not expressly authorized and approved by HHT in writing; and/or (9) interruptions or fluctuations of electrical power supply to the appliance.
- Non-HHT venting components, hearth components or other accessories used in conjunction with the appliance.
- Any part of a pre-existing fireplace system in which an insert or a decorative gas appliance is installed.
- HHT's obligation under this warranty does not extend to the appliance's capability to heat the desired space. Information is provided to assist the consumer and the dealer in selecting the proper appliance for the application. Consideration must be given to appliance location and configuration, environmental conditions, insulation and air tightness of the structure.

### **This warranty is void if:**

- The appliance has been over-fired or operated in atmospheres contaminated by chlorine, fluorine, or other damaging chemicals. Over-firing can be identified by, but not limited to, warped plates or tubes, rust colored cast iron, bubbling, cracking and discoloration of steel or enamel finishes.
- The appliance is subjected to prolonged periods of dampness or condensation.
- There is any damage to the appliance or other components due to water or weather damage which is the result of, but not limited to, improper chimney or venting installation.

### **LIMITATIONS OF LIABILITY:**

- The owner's exclusive remedy and HHT's sole obligation under this warranty, under any other warranty, express or implied, or in contract, tort or otherwise, shall be limited to replacement, repair, or refund, as specified above. In no event will HHT be liable for any incidental or consequential damages caused by defects in the appliance. Some states do not allow exclusions or limitation of incidental or consequential damages, so these limitations may not apply to you. This warranty gives you specific rights; you may also have other rights, which vary from state to state. EXCEPT TO THE EXTENT PROVIDED BY LAW, HHT MAKES NO EXPRESS WARRANTIES OTHER THAN THE WARRANTY SPECIFIED HEREIN. THE DURATION OF ANY IMPLIED WARRANTY IS LIMITED TO DURATION OF THE EXPRESSED WARRANTY SPECIFIED ABOVE.

## F. Contact Information



No one builds a better fire

Heat & Glo, a brand of Hearth & Home Technologies  
 7571 215th Street West, Lakeville, MN 55044  
[www.heatnglo.com](http://www.heatnglo.com)

Please contact your Heat & Glo dealer with any questions or concerns.  
 For the location of your nearest Heat & Glo dealer,  
 please visit [www.heatnglo.com](http://www.heatnglo.com).

### - NOTES -

---

---

---

---

---

---

---



---

---

---

---

---

<b>CAUTION</b>		
<b>DO NOT DISCARD THIS MANUAL</b>		
	<ul style="list-style-type: none"> <li>• Important operating and maintenance instructions included.</li> </ul>	<ul style="list-style-type: none"> <li>• Read, understand and follow these instructions for safe installation and operation.</li> </ul>
	<ul style="list-style-type: none"> <li>• Leave this manual with party responsible for use and operation.</li> </ul>	

This product may be covered by one or more of the following patents: (United States) 5601073, 5613487, 5647340, 5890485, 5941237, 6006743, 6019099, 6053165, 6145502, 6374822, 6484712, 6601579, 6769426, 6863064, 7077122, 7098269, 7258116, 7470729, 8147240 or other U.S. and foreign patents pending.

2000-945B