

# Installation Manual

## Installation and Appliance Setup

**INSTALLER:** Leave this manual with party responsible for use and operation.  
**OWNER:** Retain this manual for future reference.

**NOTICE: DO NOT** discard this manual!

**HEAT & GLO**

No one builds a better fire

**Models:**

**6000CMOD-IFT**

**8000CMOD-IFT**

**GAS-FIRED**

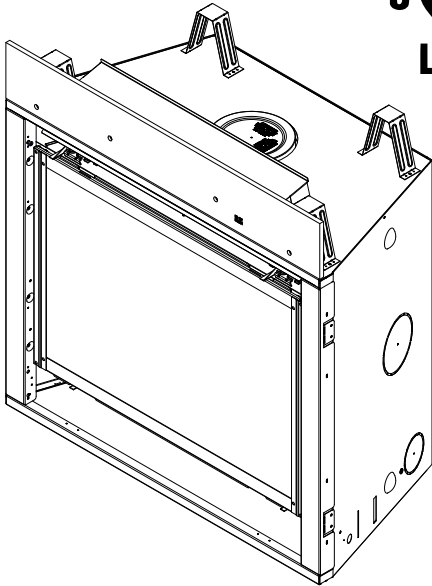

This appliance may be installed as an OEM installation in manufactured home (USA only) or mobile home and must be installed in accordance with the manufacturer's instructions and the *Manufactured Home Construction and Safety Standard, Title 24 CFR, Part 3280* in the United States, or the *Standard for Installation in Mobile Homes, CAN/CSA Z240 MH Series*, in Canada.

This appliance is only for use with the type(s) of gas indicated on the rating plate. This appliance is not convertible for use with other gases, unless a certified kit is used.

In the Commonwealth of Massachusetts installation must be performed by a licensed plumber or gas fitter.

See Table of Contents for location of additional Commonwealth of Massachusetts requirements.

**⚠ WARNING:**  
**FIRE OR EXPLOSION HAZARD**  
Failure to follow safety warnings exactly could result in serious injury, death, or property damage.

- **DO NOT** store or use gasoline or other flammable vapors and liquids in the vicinity of this or any other appliance.
- **What to do if you smell gas**
  - **DO NOT** try to light any appliance.
  - **DO NOT** touch any electrical switch. **DO NOT** use any phone in your building.
  - Leave the building immediately.
  - Immediately call your gas supplier from a neighbor's phone. Follow the gas supplier's instructions.
  - If you cannot reach your gas supplier, call the fire department.
- Installation and service must be performed by a qualified installer, service agency, or the gas supplier.

**⚠ DANGER**



**HOT GLASS WILL CAUSE BURNS.**

**DO NOT TOUCH GLASS UNTIL COOLED.**

**NEVER ALLOW CHILDREN TO TOUCH GLASS.**

A barrier designed to reduce the risk of burns from the hot viewing glass is provided with this appliance and must be installed for the protection of children and other at-risk individuals.

## ▲ Safety Alert Key:

- **DANGER!** Indicates a hazardous situation which, if not avoided will result in death or serious injury.
- **WARNING!** Indicates a hazardous situation which, if not avoided could result in death or serious injury.
- **CAUTION!** Indicates a hazardous situation which, if not avoided, could result in minor or moderate injury.
- **NOTICE:** Used to address practices not related to personal injury.

**Note:** The term “recommend” or “recommended” does not indicate a requirement. It is a best practice suggested by Hearth & Home Technologies®.

## Table of Contents

Installation Standard Work Checklist . . . . .	3
--	---

### 1 Product Specific and Important Safety Information

A. Appliance Certification . . . . .	4
B. Glass Specifications . . . . .	4
C. BTU Specifications . . . . .	4
D. High Altitude Installations . . . . .	4
E. Non-Combustible Materials Specification . . . . .	4
F. Combustible Materials Specification . . . . .	4
G. Electrical Codes . . . . .	4
H. California . . . . .	4
I. Requirements for the Commonwealth of Massachusetts . . . . .	5

### 2 Getting Started

A. Design and Installation Considerations . . . . .	6
B. Good Faith Wall Surface . . . . .	6
C. Tools and Supplies Needed . . . . .	6
D. Inspect Appliance and Components . . . . .	7

### 3 Framing and Clearances

A. Appliance/Decorative Front Dimension Diagrams . . . . .	8
B. Clearances to Combustibles . . . . .	14
C. Constructing the Appliance Chase . . . . .	16
D. Floor Protection . . . . .	16

### 4 Termination Location and Vent Information

A. Vent Termination Minimum Clearances . . . . .	17
B. Vent Terminal Clearances . . . . .	18
C. Approved Pipe . . . . .	19
D. Use of Elbows . . . . .	20
E. Measuring Standards . . . . .	21
F. Vent Diagrams . . . . .	22

### 5 Vent Clearances and Framing

A. Pipe Clearances to Combustibles . . . . .	29
B. Wall Penetration Framing . . . . .	29
C. Ceiling Firestop/Floor Penetration Framing . . . . .	30
D. Install Attic Insulation Shield . . . . .	30

### 6 Appliance Preparation

A. Vent Collar Preparation . . . . .	31
B. Installing Optional Heat Management Systems . . . . .	32
C. Securing and Leveling the Appliance . . . . .	33
D. Installing the Non-combustible Board . . . . .	33

### 7 Venting and Chimneys

A. Assemble Vent Sections (DVP Pipe) . . . . .	34
B. Assemble Vent Sections (SLP Pipe) . . . . .	35
C. Assemble Slip Sections . . . . .	36
D. Secure the Vent Sections . . . . .	37
E. Disassemble Vent Sections . . . . .	37
F. Vertical Termination Requirements . . . . .	38
G. Horizontal Termination Requirements . . . . .	39

### 8 Electrical Information

A. General Information . . . . .	41
B. Wiring Requirements . . . . .	42

### 9 Gas Information

A. Fuel Conversion . . . . .	44
B. Gas Pressure . . . . .	44
C. Gas Connection . . . . .	44
D. High Altitude Installations . . . . .	44
E. Air Shutter Setting . . . . .	45

### 10 Finishing

A. Facing Material . . . . .	46
B. Mantel and Wall Projections . . . . .	47
C. Decorative Fronts . . . . .	48

### 11 Appliance Setup

A. Remove Fixed Glass Assembly . . . . .	51
B. Remove the Shipping Materials . . . . .	51
C. Clean the Appliance . . . . .	51
D. Glass Panel Installation . . . . .	52
E. Media Placement . . . . .	53
F. IntelliFire Touch® Control System Setup . . . . .	54
G. Fixed Glass Assembly . . . . .	54
H. Install Decorative Front . . . . .	54

### 12 Reference Materials

A. Vent Components Diagrams . . . . .	55
B. Accessories . . . . .	66

➔ = Contains updated information.

# Installation Standard Work Checklist

## ATTENTION INSTALLER: Follow this Standard Work Checklist

This standard work checklist is to be used by the installer in conjunction with, not instead of, the instructions contained in this installation manual.

<b>Customer:</b> _____ <b>Lot/Address:</b> _____ <b>Model (circle one):</b> 6000CMOD-IFT 8000CMOD-IFT	<b>Date Installed:</b> _____ <b>Location of Fireplace:</b> _____ <b>Installer:</b> _____ <b>Dealer/Distributor Phone #</b> _____ <b>Serial #:</b> _____
--	---

**WARNING! Risk of Fire or Explosion!** Failure to install appliance according to these instructions could lead to a fire or explosion.

<u>Appliance Install</u>	YES	IF NO, WHY?
Verified that the chase is insulated and sealed. (Pg. 16)	<input type="checkbox"/>	_____
Required non-combustible board is installed. (Pg. 33)	<input type="checkbox"/>	_____
Verified clearances to combustibles. (Pg. 14-15)	<input type="checkbox"/>	_____
Fireplace is leveled and secured. (Pg. 33)	<input type="checkbox"/>	_____
<b><u>Venting/Chimney Section 7 (Pg 34-40)</u></b>		
Venting configuration complies to vent diagrams.	<input type="checkbox"/>	_____
Venting installed, locked and secured in place with proper clearance.	<input type="checkbox"/>	_____
Elbow heat shield installed per requirements. (Pg 23, 29)	<input type="checkbox"/>	_____
Firestops installed.	<input type="checkbox"/>	_____
Attic insulation shield installed.	<input type="checkbox"/>	_____
Exterior wall/Roof flashing installed and sealed.	<input type="checkbox"/>	_____
Terminations installed and sealed.	<input type="checkbox"/>	_____
<b><u>Electrical Section 8 (Pg 41-43)</u></b>		
Unswitched power (110-120 VAC) provided to the appliance.	<input type="checkbox"/>	_____
Switch wires properly installed.	<input type="checkbox"/>	_____
<b><u>Gas Section 9 (Pg 44-45)</u></b>		
Proper appliance for fuel type.	<input type="checkbox"/>	_____
Leak check performed and inlet pressure verified.	<input type="checkbox"/>	_____
Verified proper air shutter setting for installation type.	<input type="checkbox"/>	_____
<b><u>Finishing Section 10 (Pg 46-50)</u></b>		
Combustible materials not installed in non-combustible areas.	<input type="checkbox"/>	_____
Verified all clearances meet installation manual requirements.	<input type="checkbox"/>	_____
Mantels and wall projections comply with installation manual requirements.	<input type="checkbox"/>	_____
<b><u>Appliance Setup Section 11 (Pg 51-54)</u></b>		
All packaging and protective materials removed (inside & outside of appliance).	<input type="checkbox"/>	_____
Refractory and media installed correctly.	<input type="checkbox"/>	_____
Glass assembly installed and secured.	<input type="checkbox"/>	_____
Accessories installed properly.	<input type="checkbox"/>	_____
Decorative front properly installed.	<input type="checkbox"/>	_____
Manual bag and all of its contents are removed from inside/under the appliance and given to party responsible for use and operation.	<input type="checkbox"/>	_____
Started appliance and verified no gas leaks exist.	<input type="checkbox"/>	_____

**Hearth & Home Technologies recommends the following:**

- Photographing the installation and copying this checklist for your file.
- That this checklist remain visible at all times on the appliance until the installation is complete.

**Comments:** Further description of the issues, who is responsible (Installer/ Builder/ Other Trades, etc) and corrective action needed \_\_\_\_\_

Comments Communicated to party responsible \_\_\_\_\_ by \_\_\_\_\_ on \_\_\_\_\_  
 (Builder / Gen. Contractor/) (Installer) (Date)

➔ = Contains updated information.

2509-982D 6/20

# 1 Product Specific and Important Safety Information

## A. Appliance Certification

**MODELS:** 6000CMOD-IFT, 8000CMOD-IFT  
**LABORATORY:** Underwriters Laboratories, Inc. (UL)  
**TYPE:** Direct Vent Heater  
**STANDARD:** CSA / ANSI Z21.88:19 • CSA 2.33:19

This product is listed to ANSI standards for “Vented Gas Fireplace Heaters” and applicable sections of “Gas Burning Heating Appliances for Manufactured Homes and Recreational Vehicles”, and “Gas Fired Appliances for Use at High Altitudes”.

**NOTICE:** This installation must conform with local codes. In the absence of local codes you must comply with the National Fuel Gas Code, ANSI Z223.1-latest edition in the U.S.A. and the CAN/CGA B149 Installation Codes in Canada.

**NOT INTENDED FOR USE AS A PRIMARY HEAT SOURCE.**  
This appliance is tested and approved as either supplemental room heat or as a decorative appliance. It should not be factored as primary heat in residential heating calculations.

## B. Glass Specifications

This appliance is equipped with ceramic glass with an anti-reflective coating. Replace glass only with glass with identical specifications. Please contact your dealer for replacement glass.

## C. BTU Specifications

Models (U.S. or Canada)		Maximum Input BTU/h	Minimum Input BTU/h	Orifice Size (DMS)
6000CMOD-IFT (NG)	(0-2000 FT)	34,000	17,500	35
8000CMOD-IFT (NG)	(0-2000 FT)	35,500	19,000	33

## D. High Altitude Installations

**NOTICE:** If the heating value of the gas has been reduced, these rules do not apply. Check with your local gas utility or authorities having jurisdiction.

When installing above 2000 feet elevation:

- In the USA: Reduce input rate 4% for each 1000 feet above 2000 feet.
- In CANADA: Input ratings are certified without a reduction of input rate for elevations up to 4500 feet (1370 m) above sea level. Please consult provincial and/or local authorities having jurisdiction for installations at elevations above 4500 feet (1370 m).

Check with your local gas utility to determine proper orifice size.

## E. Non-Combustible Materials Specification

Material which will not ignite and burn. Such materials are those consisting entirely of steel, iron, brick, tile, concrete, slate, glass or plasters, or any combination thereof.

Materials that are reported as passing **ASTM E 136, Standard Test Method for Behavior of Materials in a Vertical Tube Furnace at 750 °C** shall be considered non-combustible materials.

## F. Combustible Materials Specification

Materials made of or surfaced with wood, compressed paper, plant fibers, plastics, or other material that can ignite and burn, whether flame proofed or not, or plastered or unplastered shall be considered combustible materials.

## G. Electrical Codes

**NOTICE:** This appliance must be electrically wired and grounded in accordance with local codes or, in the absence of local codes, with **National Electric Code ANSI/NFPA 70-latest edition or the Canadian Electric Code CSA C22.1.**

- A 110-120 VAC circuit for this product must be protected with ground-fault circuit-interrupter protection, in compliance with the applicable electrical codes, when it is installed in locations such as in bathrooms or near sinks.

## H. California



**WARNING:** This product and the fuels used to operate this product (liquid propane or natural gas), and the products of combustion of such fuels, can expose you to chemicals including benzene, which is known to the State of California to cause cancer and reproductive harm. For more information go to: [www.P65Warnings.ca.gov](http://www.P65Warnings.ca.gov).

**Note:** The following requirements reference various Massachusetts and national codes not contained in this document.

## I. Requirements for the Commonwealth of Massachusetts

For all side wall horizontally vented gas fueled equipment installed in every dwelling, building or structure used in whole or in part for residential purposes, including those owned or operated by the Commonwealth and where the side wall exhaust vent termination is less than seven (7) feet above finished grade in the area of the venting, including but not limited to decks and porches, the following requirements shall be satisfied:

### Installation of Carbon Monoxide Detectors

At the time of installation of the side wall horizontal vented gas fueled equipment, the installing plumber or gas fitter shall observe that a hard wired carbon monoxide detector with an alarm and battery back-up is installed on the floor level where the gas equipment is to be installed. In addition, the installing plumber or gas fitter shall observe that a battery operated or hard wired carbon monoxide detector with an alarm is installed on each additional level of the dwelling, building or structure served by the side wall horizontal vented gas fueled equipment. It shall be the responsibility of the property owner to secure the services of qualified licensed professionals for the installation of hard wired carbon monoxide detectors.

In the event that the side wall horizontally vented gas fueled equipment is installed in a crawl space or an attic, the hard wired carbon monoxide detector with alarm and battery back-up may be installed on the next adjacent floor level.

In the event that the requirements of this subdivision can not be met at the time of completion of installation, the owner shall have a period of thirty (30) days to comply with the above requirements; provided, however, that during said thirty (30) day period, a battery operated carbon monoxide detector with an alarm shall be installed.

### Approved Carbon Monoxide Detectors

Each carbon monoxide detector as required in accordance with the above provisions shall comply with NFPA 720 and be ANSI/UL 2034 listed and IAS certified.

### Signage

A metal or plastic identification plate shall be permanently mounted to the exterior of the building at a minimum height of eight (8) feet above grade directly in line with the exhaust vent terminal for the horizontally vented gas fueled heating appliance or equipment. The sign shall read, in print size no less than one-half (1/2) in. in size, "**GAS VENT DIRECTLY BELOW. KEEP CLEAR OF ALL OBSTRUCTIONS**".

## Inspection

The state or local gas inspector of the side wall horizontally vented gas fueled equipment shall not approve the installation unless, upon inspection, the inspector observes carbon monoxide detectors and signage installed in accordance with the provisions of 248 CMR 5.08(2)(a)1 through 4.

## Exemptions

The following equipment is exempt from 248 CMR 5.08(2)(a)1 through 4:

- The equipment listed in Chapter 10 entitled "Equipment Not Required To Be Vented" in the most current edition of NFPA 54 as adopted by the Board; and
- Product Approved side wall horizontally vented gas fueled equipment installed in a room or structure separate from the dwelling, building or structure used in whole or in part for residential purposes.

## MANUFACTURER REQUIREMENTS

### Gas Equipment Venting System Provided

When the manufacturer of Product Approved side wall horizontally vented gas equipment provides a venting system design or venting system components with the equipment, the instructions provided by the manufacturer for installation of the equipment and the venting system shall include:

- Detailed instructions for the installation of the venting system design or the venting system components; and
- A complete parts list for the venting system design or venting system.

### Gas Equipment Venting System NOT Provided

When the manufacturer of a Product Approved side wall horizontally vented gas fueled equipment does not provide the parts for venting the flue gases, but identifies "special venting systems", the following requirements shall be satisfied by the manufacturer:

- The referenced "special venting system" instructions shall be included with the appliance or equipment installation instructions; and
- The "special venting systems" shall be Product Approved by the Board, and the instructions for that system shall include a parts list and detailed installation instructions.

A copy of all installation instructions for all Product Approved side wall horizontally vented gas fueled equipment, all venting instructions, all parts lists for venting instructions, and/or all venting design instructions shall remain with the appliance or equipment at the completion of the installation.

**See Gas Connection section for additional Commonwealth of Massachusetts requirements.**

## 2 Getting Started

### A. Design and Installation Considerations

Heat & Glo direct vent gas appliances are designed to operate with all combustion air siphoned from outside of the building and all exhaust gases expelled to the outside. No additional outside air source is required.

Installation **MUST** comply with local, regional, state and national codes and regulations. Consult insurance carrier, local building inspector, fire officials or authorities having jurisdiction over restrictions, installation inspection and permits.

**Before** installing, determine the following:

- Where the appliance is to be installed.
- The vent system configuration to be used.
- Gas supply piping requirements.
- Provisions for optional heat management system.
- Electrical wiring requirements.
- Framing and finishing details.
- Whether optional accessories—devices such as a fan, wall switch, or remote control—are desired.

Installation and service of this appliance should be performed by qualified personnel. Hearth & Home Technologies recommends HHT Factory Trained or NFI certified professionals.



Improper installation, adjustment, alteration, service or maintenance can cause injury or property damage. For assistance or additional information, consult a qualified service technician, service agency or your dealer.

### B. Good Faith Wall Surface

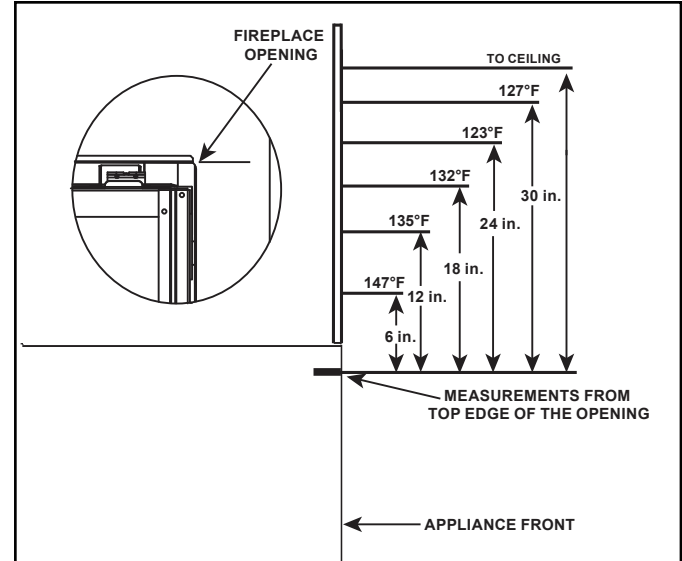

Figure 2.1 Good Faith Wall Surface Temperatures Above Appliance

If installing a television (TV) above the appliance, see Section 3 of the appliance Owner's Manual.

**NOTICE:** Surface temperatures listed above are taken with a temperature measuring probe as prescribed by the test standard used for appliance certification. Temperatures on walls or mantels taken with an infrared thermometer may yield increased temperatures of up to 30 °F (17 °C) or more depending on the thermometer settings and material characteristics being measured. Use appropriate finishing materials that are able to withstand these conditions. For additional finishing guidelines, see Section 10.

### C. Tools and Supplies Needed

Before beginning the installation be sure that the following tools and building supplies are available.

- |   |                                   |
|---|-----------------------------------|
| Tape measure  | Framing material                  |
| Pliers  | Hammer                            |
| Phillips screwdriver  | Manometer                         |
| Gloves  | Framing square                    |
| Voltmeter   | Electric drill and bits (1/4 in.) |
| Plumb line  | Safety glasses                    |
| Level   | Reciprocating saw                 |
| Flat blade screwdriver  |                                   |
| Non-corrosive leak check solution                             |                                   |
| 1/2 - 3/4 in. length, #6 or #8 Self-drilling screws           |                                   |
| Caulking material (300 °F minimum continuous exposure rating) |                                   |
| One 1/4 in. female connection (for optional fan).             |                                   |

## D. Inspect Appliance and Components

- Carefully remove the appliance and components from the packaging.
- The vent system components and decorative fronts may be shipped in separate packages.
- Report to your dealer any parts damaged in shipment, particularly the condition of the glass.
- **Read all of the instructions before starting the installation. Follow these instructions carefully during the installation to ensure maximum safety and benefit.**

**WARNING! Risk of Fire or Explosion!** Damaged parts could impair safe operation. **DO NOT** install damaged, incomplete or substitute components. Keep appliance dry.

Hearth & Home Technologies disclaims any responsibility for, and the warranty will be voided by, the following actions:

- Installation and use of any damaged appliance or vent system component.
- Modification of the appliance or vent system.
- Installation other than as instructed by Hearth & Home Technologies.
- Improper positioning of the logs/media (as applicable) or the glass assembly.
- Installation and/or use of any component part not approved by Hearth & Home Technologies.

**Any such action may cause a fire hazard.**

**WARNING! Risk of Fire, Explosion or Electric Shock!** **DO NOT** use this appliance if any part has been under water. Call a qualified service technician to inspect the appliance and to replace any part of the control system and/or gas control which has been under water.

# 3 Framing and Clearances

## A. Appliance/Decorative Front Dimension Diagrams

Dimensions are actual appliance dimensions. Use for reference only. For framing dimensions and clearances refer to Section 5.

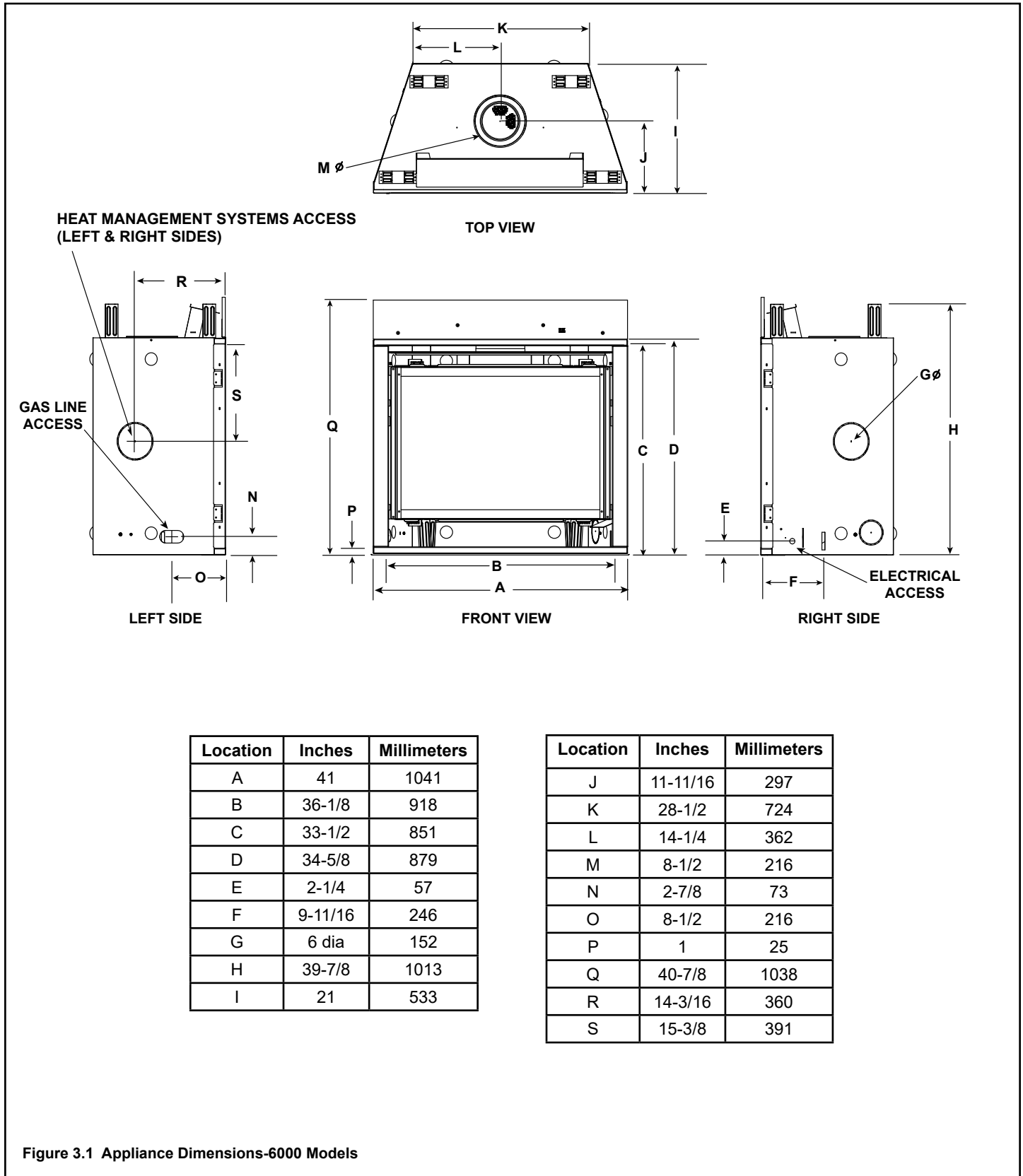
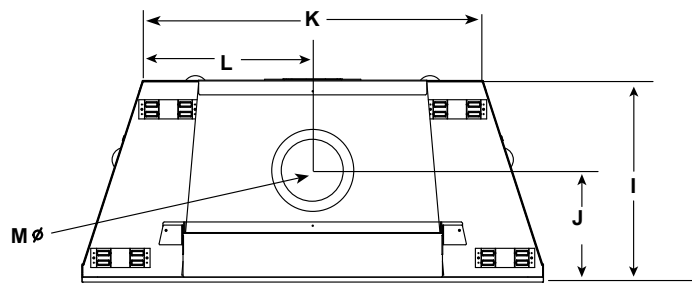

Figure 3.1 Appliance Dimensions-6000 Models





TOP VIEW

HEAT MANAGEMENT SYSTEMS ACCESS  
(LEFT & RIGHT SIDES)

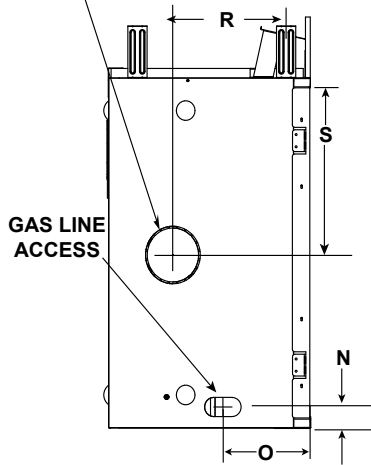

LEFT SIDE

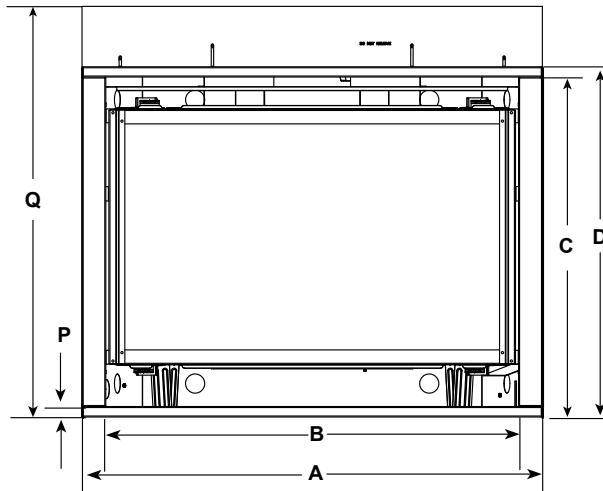

FRONT VIEW

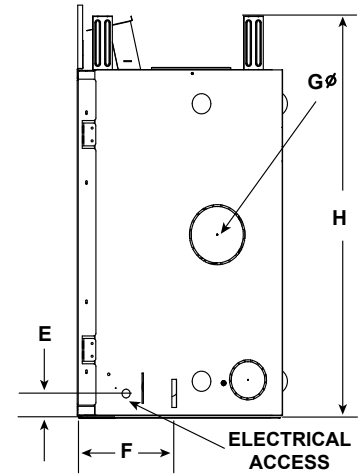

RIGHT VIEW

Location	Inches	Millimeters
A	48	1219
B	43-1/8	1096
C	35-1/2	902
D	36-5/8	930
E	2-3/8	60
F	9-15/16	252
G	6	152
H	41-7/8	1064
I	21	533

Location	Inches	Millimeters
J	11-11/16	297
K	35-1/2	901
L	17-3/4	451
M	8-1/2	216
N	2-7/8	73
O	8-1/2	216
P	1	25
Q	42-7/8	1089
R	14-1/16	357
S	17-1/16	433

Figure 3.2 Appliance Dimensions-8000 Models

## FOLIO DECORATIVE FRONTS

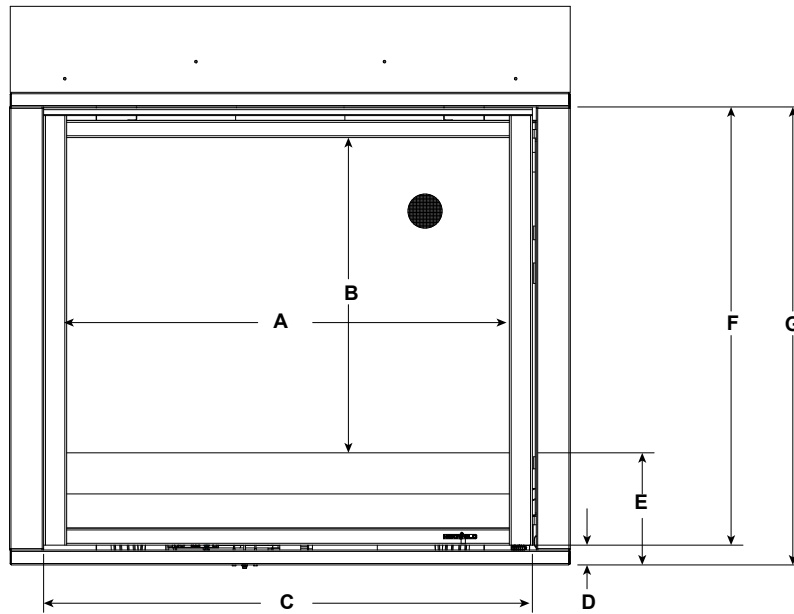

			A	B	C	D	E	F	G
6000	FOL-36	in.	32-7/16	23-1/8	35-13/16	1-1/2	8-1/4	32-1/8	33-9/16
		mm	824	587	910	38	210	816	853
8000	FOL-42	in.	39-7/16	25-5/16	42-13/16	1-1/2	8-1/4	34-1/8	35-11/16
		mm	1002	643	1087	38	210	867	907

## ARCADIA DECORATIVE FRONTS

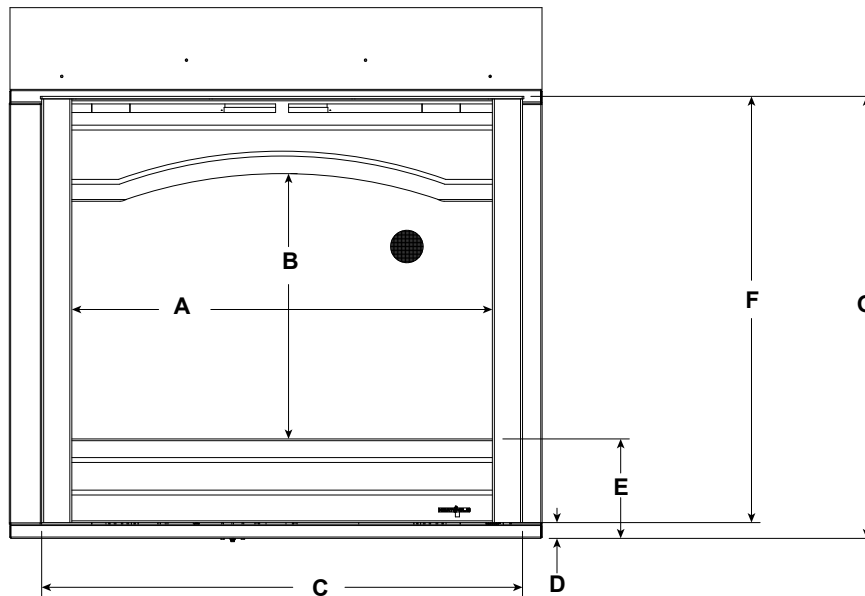

			A	B	C	D	E	F	G
6000	ARC-36	in.	32-7/16	20-1/2	37-1/4	1-1/4	7-11/16	32-7/8	34-1/8
		mm	824	521	946	32	195	835	867
8000	ARC-42	in.	39-7/16	22-7/16	44-1/4	1-1/4	7-11/16	34-13/16	36-1/16
		mm	1002	570	1124	32	195	884	916

Figure 3.3 Decorative Front Dimensions - Folio and Arcadia

## HALSTON DECORATIVE FRONTS

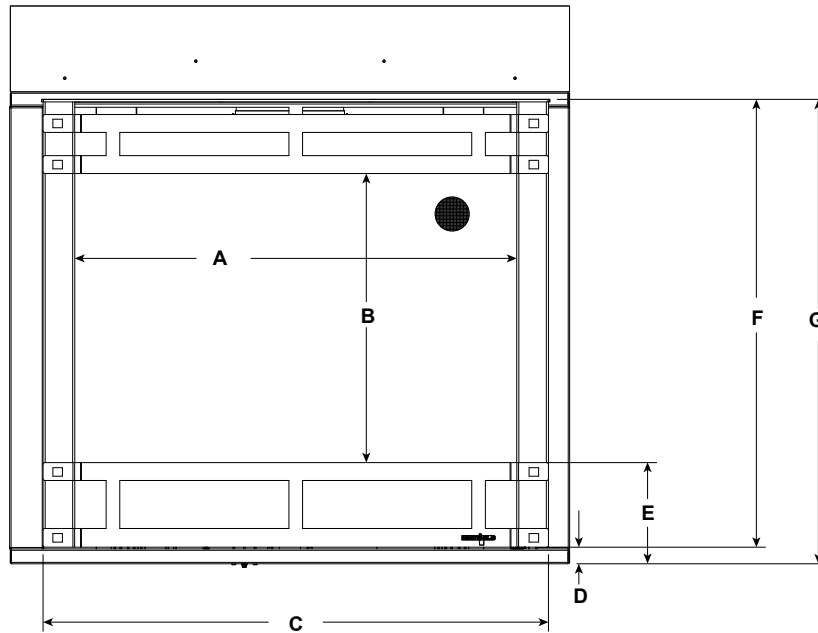

			A	B	C	D	E	F	G
6000	HAL-36	in.	32-7/16	21-1/4	37-1/4	1-1/4	7-1/4	32-7/8	34-1/8
		mm	824	540	946	32	184	835	867
8000	HAL-42	in.	39-7/16	23-1/8	44-1/4	1-1/4	7-1/4	34-13/16	36-1/16
		mm	1002	587	1124	32	184	884	916

## CHATEAU DECORATIVE FRONTS

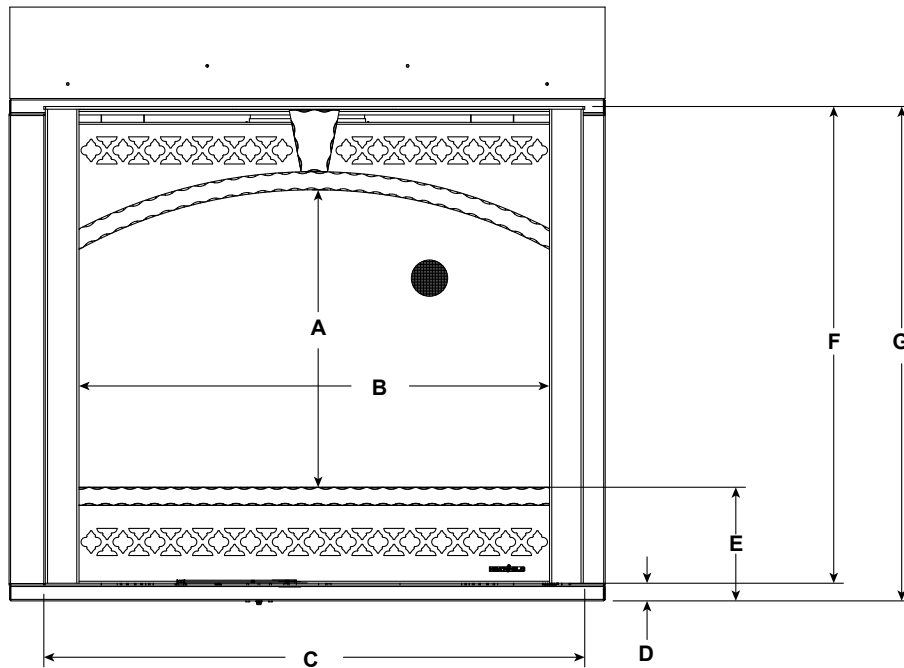

			A	B	C	D	E	F	G
6000	CHA-36	in.	20-1/2	32-7/16	37-1/4	1-1/2	7-7/8	32-7/8	34-1/8
		mm	521	824	946	38	200	835	867
8000	CHA-42	in.	22-7/16	39-7/16	44-1/8	1-1/4	7-7/8	34-13/16	36-1/16
		mm	570	1002	1121	32	200	884	916

Figure 3.4 Decorative Front Dimensions - Halston and Chateau

## CHATEAU FORGE DECORATIVE FRONTS

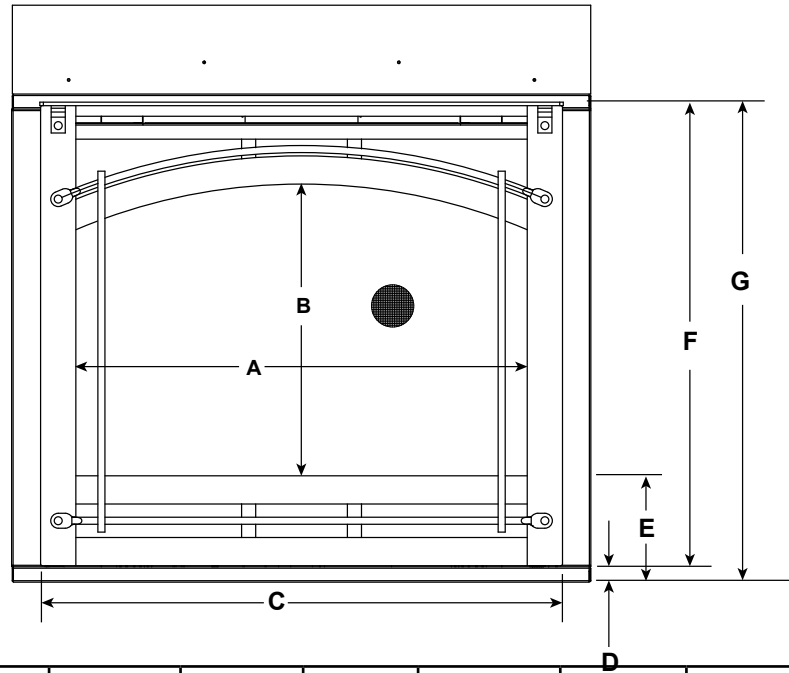

			A	B	C	D	E	F	G
6000	CHAF-36	in.	32-1/4	20-3/4	37	1-3/16	7-9/16	32-7/8	34-1/8
		mm	819	527	940	30	192	835	867
8000	CHAF-42	in.	39-1/4	22-5/8	44	1-1/4	7-5/8	34-3/4	36
		mm	997	575	1118	32	194	883	914

## GALLERIA DECORATIVE FRONTS

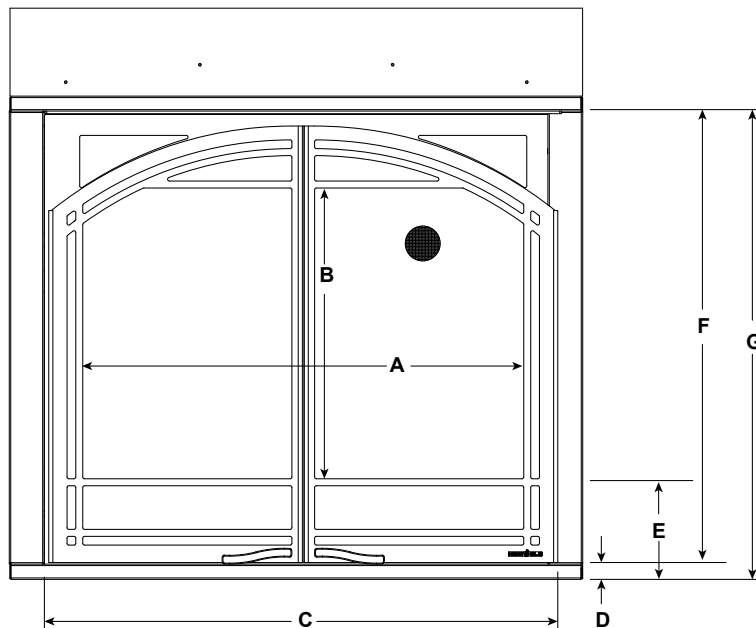

			A	B	C	D	E	F	G
6000	GALLERIA-6	in.	31-9/16	20-7/8	37-1/8	1-1/4	7-1/2	32-7/8	34-1/16
		mm	802	530	943	32	191	835	865
8000	GALLERIA-8	in.	38-9/16	22-3/4	44-1/16	1-1/4	7-1/2	34-3/4	36
		mm	979	578	1121	32	191	883	914

Figure 3.5 Decorative Front Dimensions - Chateau Forge and Galleria

## CLEAN FACE DECORATIVE FRONTS

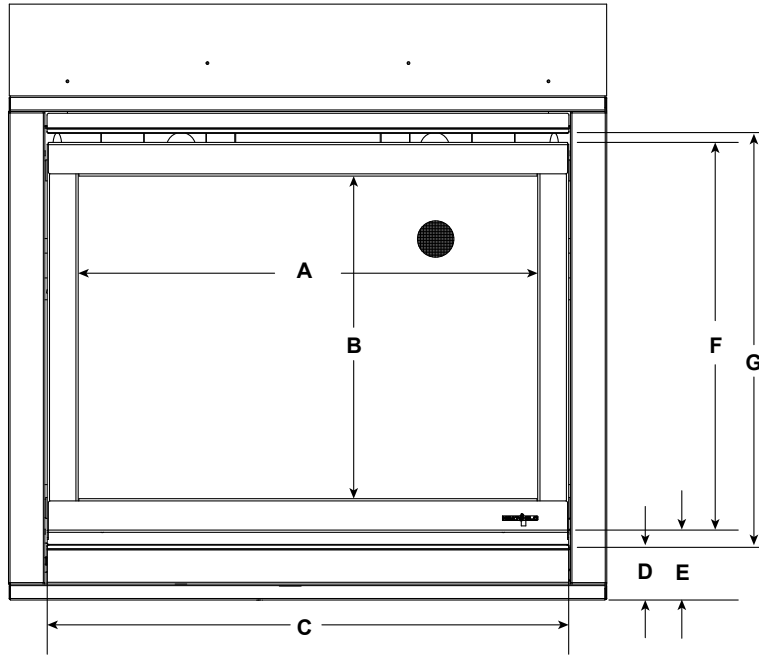

			A	B	C	D	E	F	G
6000	CF-36	in.	31-9/16	22-1/8	35-13/16	3-1/2	4-9/16	26-13/16	28-15/16
		mm	802	562	910	89	116	681	735
8000	CF-42	in.	38-1/2	24-1/16	42-3/4	3-1/2	4-9/16	28-11/16	30-13/16
		mm	978	611	1086	89	116	729	783

## IRON AGE DECORATIVE FRONTS

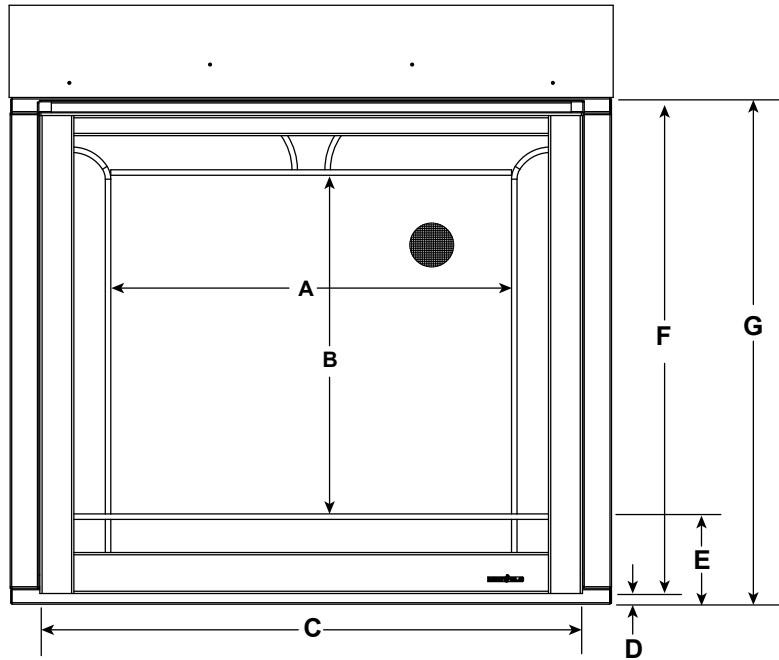

			A	B	C	D	E	F	G
6000	FSI-36	in.	27-3/8	23-1/8	37-3/16	1-1/4	6-3/4	32-7/8	34-1/8
		mm	695	587	945	32	172	835	867
8000	FSI-42	in.	34-3/8	25-3/16	44-3/16	1-1/4	6-3/4	34-13/16	36-1/16
		mm	873	640	1122	32	172	884	916

Figure 3.6 Decorative Front Dimensions - Clean Face and Iron Age

## B. Clearances to Combustibles

When selecting a location for the appliance it is important to consider the required clearances to walls. See Figure 3.5.

**WARNING! Risk of Fire or Burns!** Provide adequate clearance around air openings and for service access. Due to high temperatures, the appliance should be located out of traffic and away from furniture and draperies.

**NOTICE:** Illustrations reflect typical installations and are FOR DESIGN PURPOSES ONLY. Illustrations/diagrams are not drawn to scale. Actual installation may vary due to individual design preference.

**NOTICE:** Illustrations reflect typical installations and are FOR DESIGN PURPOSES ONLY. Illustrations/diagrams are not drawn to scale. Actual installation may vary due to individual design preference.

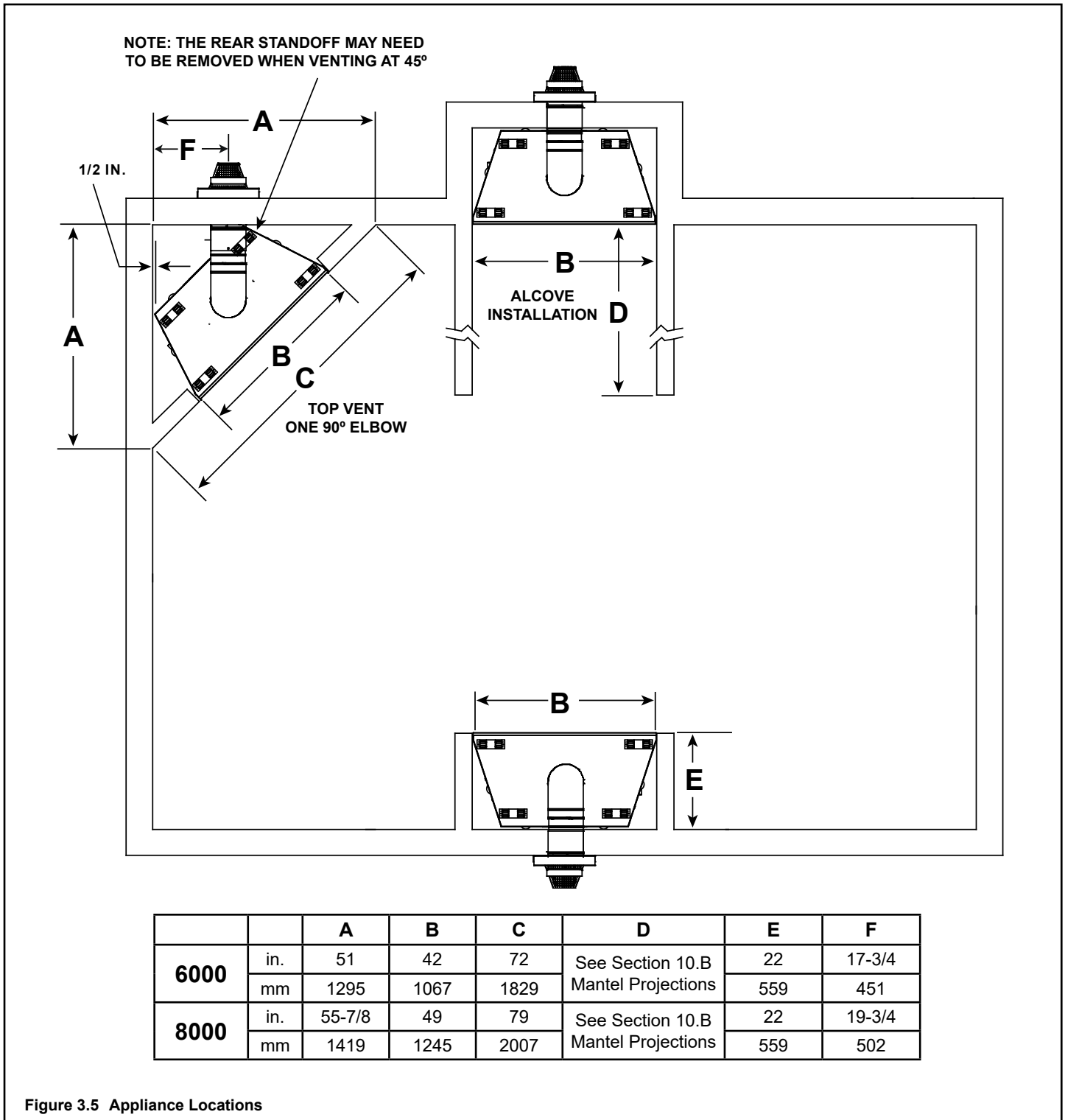

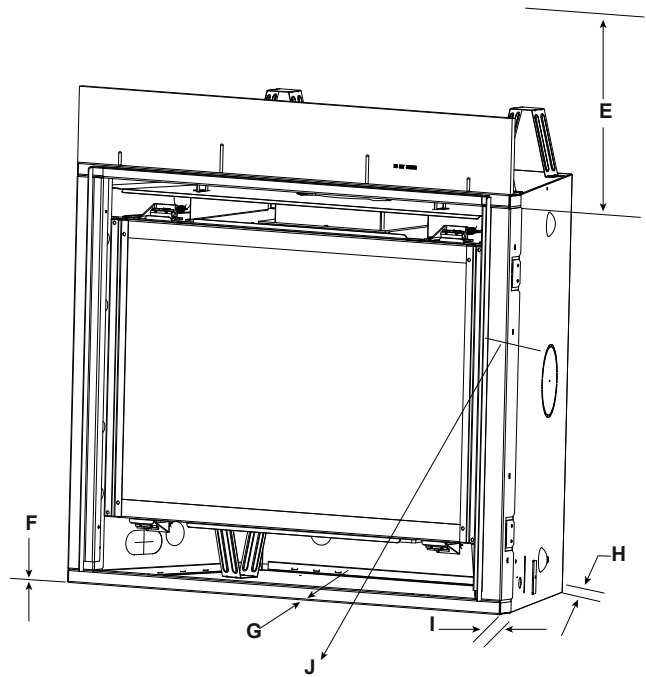
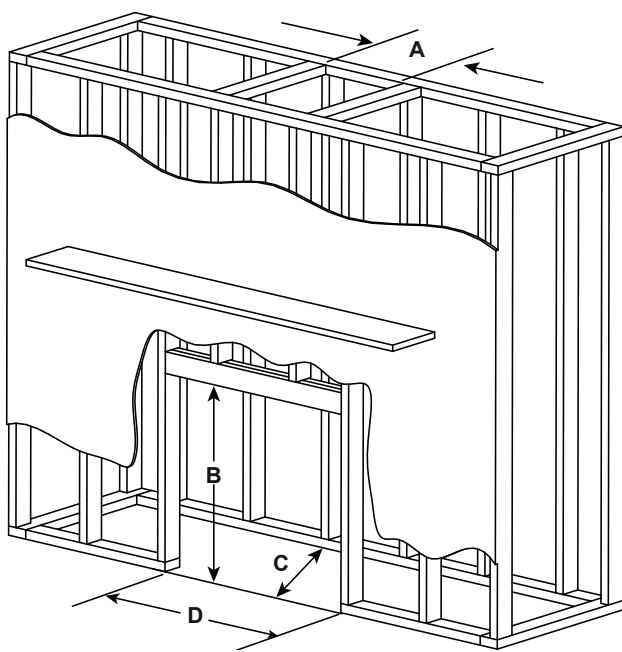
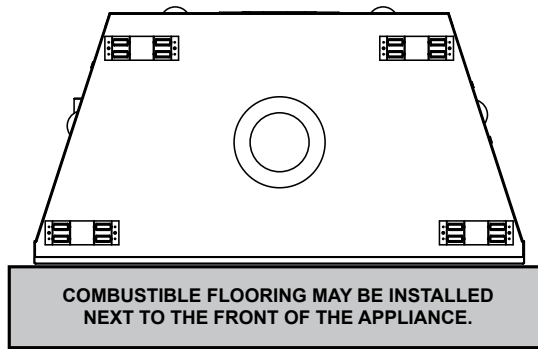

* MINIMUM FRAMING DIMENSIONS											
Models		A	B	C	D	E	F	G**	H	I	J
		Rough Opening (Width)	Rough Opening (Height)	Rough Opening (Depth)	Rough Opening (Width)	Clearance to Ceiling	Combustible Floor	Combustible Flooring	Behind Appliance	Sides of Appliance	Front of Appliance
6000	in.	10	40-1/8	22	42	32	0	0	1/2	1/2	36
	mm	254	1019	559	1067	813	0	0	13	13	914
8000	in.	10	42-1/8	22	49	32	0	0	1/2	1/2	36
	mm	254	1070	559	1245	813	0	0	13	13	914

\* Adjust framing dimensions for interior sheathing (such as sheetrock).

G\*\* For installations with vinyl flooring see section 3.D.

Figure 3.6 Clearances to Combustibles

## C. Constructing the Appliance Chase

A chase is a vertical box-like structure built to enclose the gas appliance and/or its vent system. In cooler climates the vent should be enclosed inside the chase.

**NOTICE:** Treatment of ceiling firestops and wall shield firestops and construction of the chase may vary with the type of building. These instructions are not substitutes for the requirements of local building codes. Therefore, you **MUST** check local building codes to determine the requirements to these steps.

**NOTICE:** Where required by code, install only sprinkler heads with a sprinkler activation temperature classified as Extra High.

- Sprinklers inside of chase: Keep sprinkler head away from vent and chimney.
- Heat Management applications: Maintain 36 inches of clearance to openings from which heat is discharged such as heat zone registers, etc. Refer to Section 6.B for Heat Management options allowed for this appliance.

Chases should be constructed and insulated in the same manner as the thermal envelope of the home based on the code requirements for that climate zone to prevent air leakage and draft problems. The chase is an extension of the building thermal envelope.

To further prevent drafts and air leakage, the wall shield and ceiling firestops should be caulked with caulk with a minimum of 300 °F continuous exposure rating to seal gaps. Gas line holes and other openings should be caulked with caulk with a minimum of 300 °F continuous exposure rating or stuffed with unfaced insulation. If the appliance is being installed on a cement surface, a layer of plywood may be placed underneath to prevent conducting cold up into the room.

**NOTICE:** Install appliance on hard metal or wood surfaces extending full width and depth. **DO NOT** install directly on carpeting, vinyl, tile or any combustible material other than wood.

**WARNING! Risk of Fire!** Maintain specified air space clearances to appliance and vent pipe:

- Insulation and other materials must be secured to prevent accidental contact.
- The chase must be properly blocked to prevent blown insulation or other combustibles from entering and making contact with fireplace or chimney.
- Failure to maintain airspace may cause overheating and a fire.

## D. Floor Protection

### Vinyl Flooring

Vinyl flooring is sensitive to heat. To avoid damage to the vinyl flooring, a 12 inch minimum x 12 inch minimum hearth is recommended when using vinyl flooring up to the wall. See Figure 3.7. If no hearth is used, it is recommended to provide a minimum of 30 inches of clearance in front of the appliance to the vinyl flooring OR the bottom of the appliance should be raised a minimum of 24 inches off of the floor to allow the vinyl flooring to be installed up to the wall.

**NOTICE:** Clearances that do not meet the minimum guidelines could result in damage or buckling to the vinyl flooring and is done at the installer's risk.

Hearth and Home Technologies does not recommend adhesive based vinyl flooring products due to thermal expansion during operation. Floating style flooring can be used, but will reach temperatures up to 110 °F (based on ambient temperature of 70 °F). Consult the manufacturer's flooring specifications to ensure compatibility.

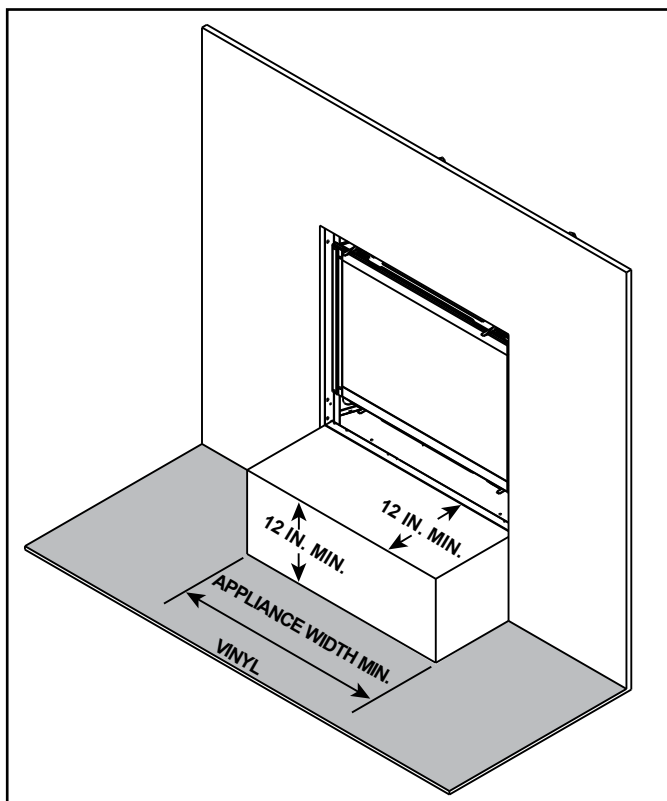

Figure 3.7 Vinyl Flooring Recommendations



# 4 Termination Location and Vent Information

## A. Vent Termination Minimum Clearances

**WARNING**

Fire Risk.  
Maintain vent clearance to combustibles as specified.

- DO NOT** pack air space with insulation or other materials.

Failure to keep insulation or other materials away from vent pipe could cause overheating and fire.

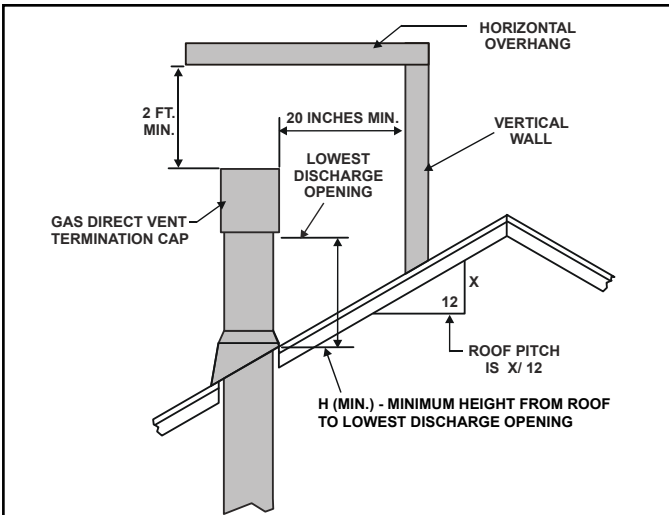

Roof Pitch	H (Min.) Ft.
Flat to 6/12.....	1.0*
Over 6/12 to 7/12.....	1.25*
Over 7/12 to 8/12.....	1.5*
Over 8/12 to 9/12.....	2.0*
Over 9/12 to 10/12.....	2.5*
Over 10/12 to 11/12.....	3.25
Over 11/12 to 12/12.....	4.0
Over 12/12 to 14/12.....	5.0
Over 14/12 to 16/12.....	6.0
Over 16/12 to 18/12.....	7.0
Over 18/12 to 20/12.....	7.5
Over 20/12 to 21/12.....	8.0

\* H minimum may vary depending on regional snowfall. Refer to local codes.

**Figure 4.1 Minimum Height From Roof to Lowest Discharge Opening**

A	B
6 in. (minimum) up to 20 in. 152 mm/508 mm	18 in. minimum 457 mm
20 in. and over	0 in. minimum

\* If using decorative cap cover(s), this distance may need to be increased. Refer to the installation instructions supplied with the decorative cap cover.

\*\* In a staggered installation with both gas and wood or fuel oil terminations, the wood or fuel oil termination cap must be higher than the gas termination cap.

**Figure 4.2 Staggered Termination Caps**

**CAUTION! Risk of Burns!** Termination caps are HOT, consider proximity to doors, traffic areas or where people may pass or gather (sidewalk, deck, patio, etc.). Listed cap shields available. Contact your dealer.

- Local codes or regulations may require different clearances.
- Hearth & Home Technologies assumes no responsibility for the improper performance of the appliance when the venting system does not meet these requirements.
- Vinyl protection kits are suggested for use with vinyl siding.
- Measure horizontal and vertical termination cap clearances as noted in Figure 4.3.

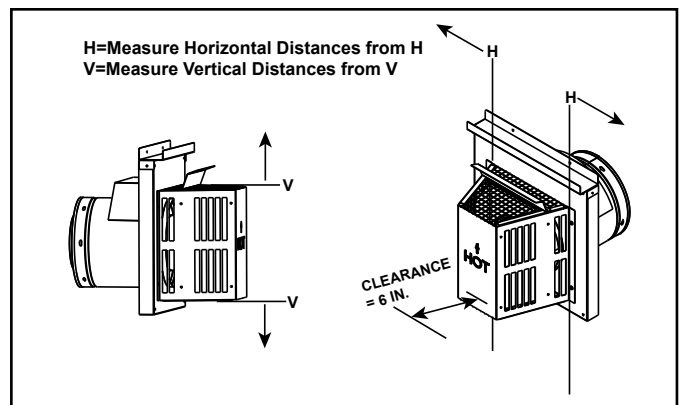

**Figure 4.3**

## B. Vent Terminal Clearances

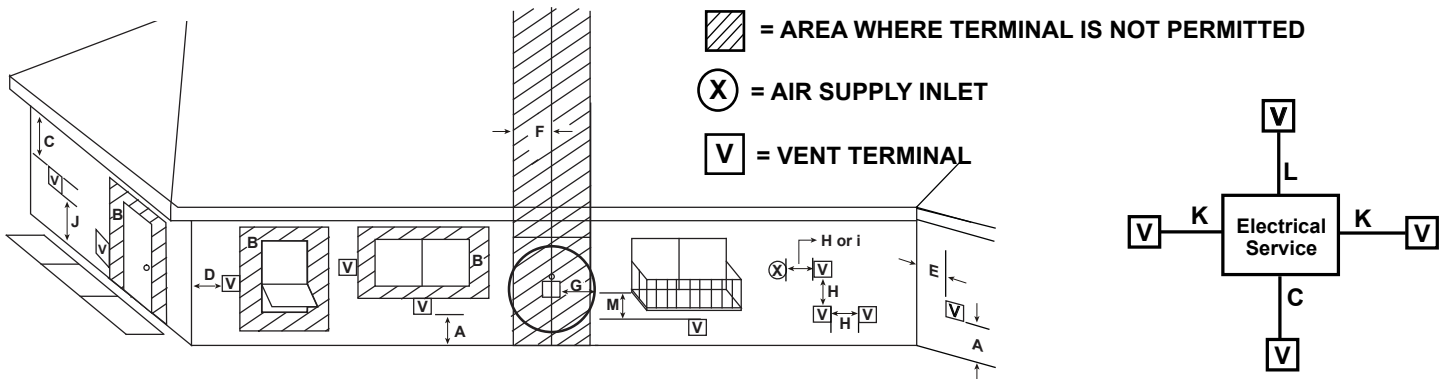

**U.S.A. Installations:** In accordance with the current ANSI Z223.1/NFPA 54, National Fuel Gas Code.

**Canadian Installations:** In accordance with the current CSA B149.1, Natural Gas and Propane Installation Code.

		U.S.A.	CANADA
A	Clearance above grade, veranda, porch, deck, or balcony	12 in. (305 mm)	12 in. (305 mm)
B	Clearance to window or door that may be opened, or to permanently closed window U.S.A.: = 9 in. min. (229 mm min.) CANADA: = 12 in. min. (305 mm min.)		
C	clearance below unventilated soffit	18 in. (457 mm)	18 in. (457 mm)
	clearance below ventilated soffit	18 in. (457 mm)	18 in. (457 mm)
	clearance below any vinyl soffits and electrical service	30 in. (762 mm)	30 in. (762 mm)
D	clearance to outside corner	6 in. (152 mm)	6 in. (152 mm)
E	clearance to inside corner	6 in. (152 mm)	6 in. (152 mm)
F	not to be installed above a gas meter/regulator assembly within 3 feet horizontally from the center-line of the regulator	3 ft (914 mm)	3 ft (914 mm)
G	clearance to gas service regulator vent outlet	3 ft (914 mm)	3 ft (914 mm)
H	clearance to non-mechanical air supply inlet to building or the combustion air inlet to any other appliance termination (mechanical or non-mechanical)	9 in. min. (229 mm min.)	12 in. min. (305 mm min.)
I	clearance to a mechanical (powered) air supply inlet *** (All mechanical air intakes within 10 feet of a horizontal termination cap must be a minimum of 3 feet below termination.)	3 ft (914 mm)***	6 ft (1.8 m)
J	On <b>public</b> property: clearance above paved sidewalk or a paved driveway.	7 ft (2.1 m)	7 ft (2.1 m)**
	**(A vent shall not terminate directly above a sidewalk or paved driveway which is located between two single family dwellings and serves both dwellings.)		
K	clearance from sides of electrical service	6 in. (152 mm)	6 in. (152 mm)
	Location of the vent termination must not interfere with access to the electrical service.		
L	clearance above electrical service	12 in. (305 mm)	12 in. (305 mm)
	Location of the vent termination must not interfere with access to the electrical service.		
M	clearance under veranda, porch, deck, balcony or overhang *(Permitted only if veranda, porch, deck, or balcony is fully open on a minimum of two sides beneath the floor.)	18 in. (457 mm)	12 in. (305 mm)*
	vinyl or composite overhang	42 in. (1067 mm)	42 in. (1067 mm)

**Figure 4.4 Minimum Clearances for Termination**

### C. Approved Pipe

This appliance is approved for use with Hearth & Home Technologies DVP or SLP venting systems. Refer to Section 12.A for vent component information and dimensions. Only use listed decorative termination caps/shrouds with Hearth & Home Technologies approved venting systems.

**DO NOT** mix pipe, fittings or joining methods from different manufacturers.

The pipe is tested to be run inside an enclosed wall. There is no requirement for inspection openings at each joint within the wall.

**WARNING! Risk of Fire or Asphyxiation.** *This appliance requires a separate vent. DO NOT vent to a pipe serving a separate solid fuel burning appliance.*

## D. Use of Elbows

Diagonal runs have both vertical and horizontal vent aspects when calculating the effects. Use the rise for the vertical aspect and the run for the horizontal aspect. See Figure 4.5.

Two 45° elbows may be used in place of one 90° elbow. On 45° runs, one foot of diagonal is equal to 8-1/2 in. (216 mm) horizontal run and 8-1/2 in. (216 mm) vertical run. A length of straight pipe is allowed between two 45° elbows. See Figure 4.5.

Figure 4.6 shows the vertical and horizontal offsets for DVP or SLP elbows.

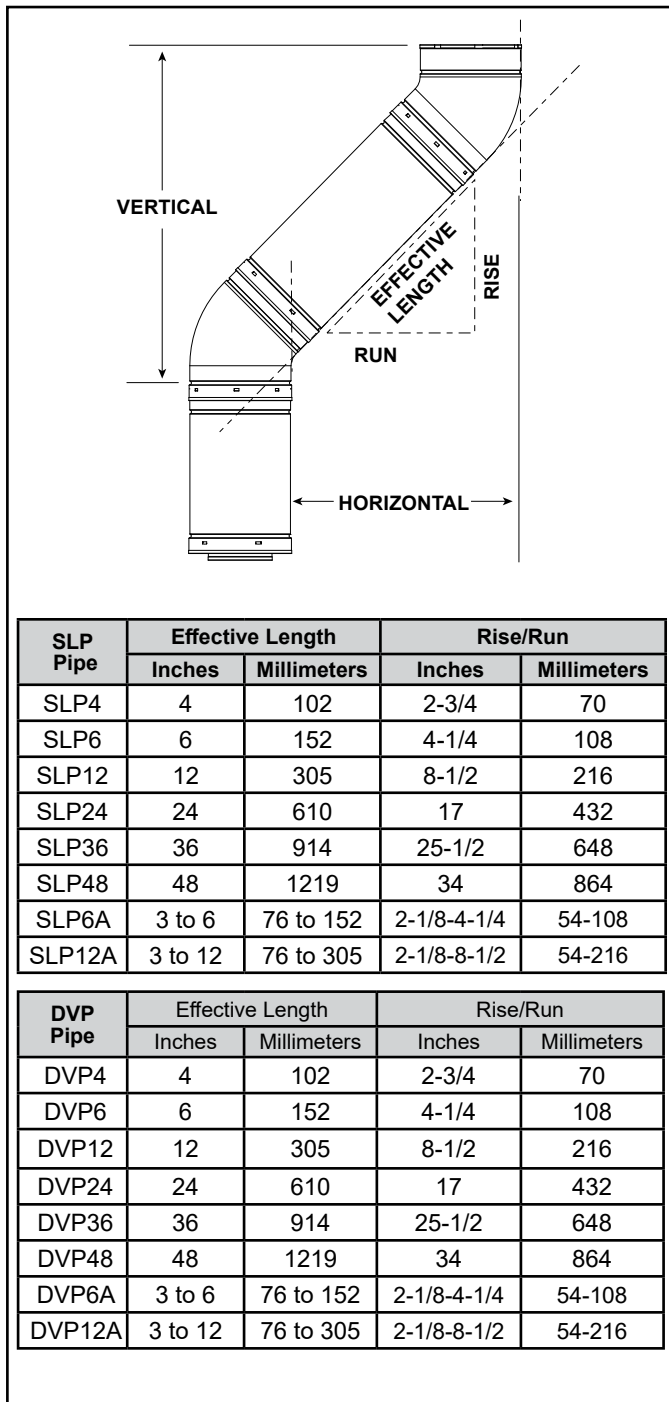

Figure 4.5

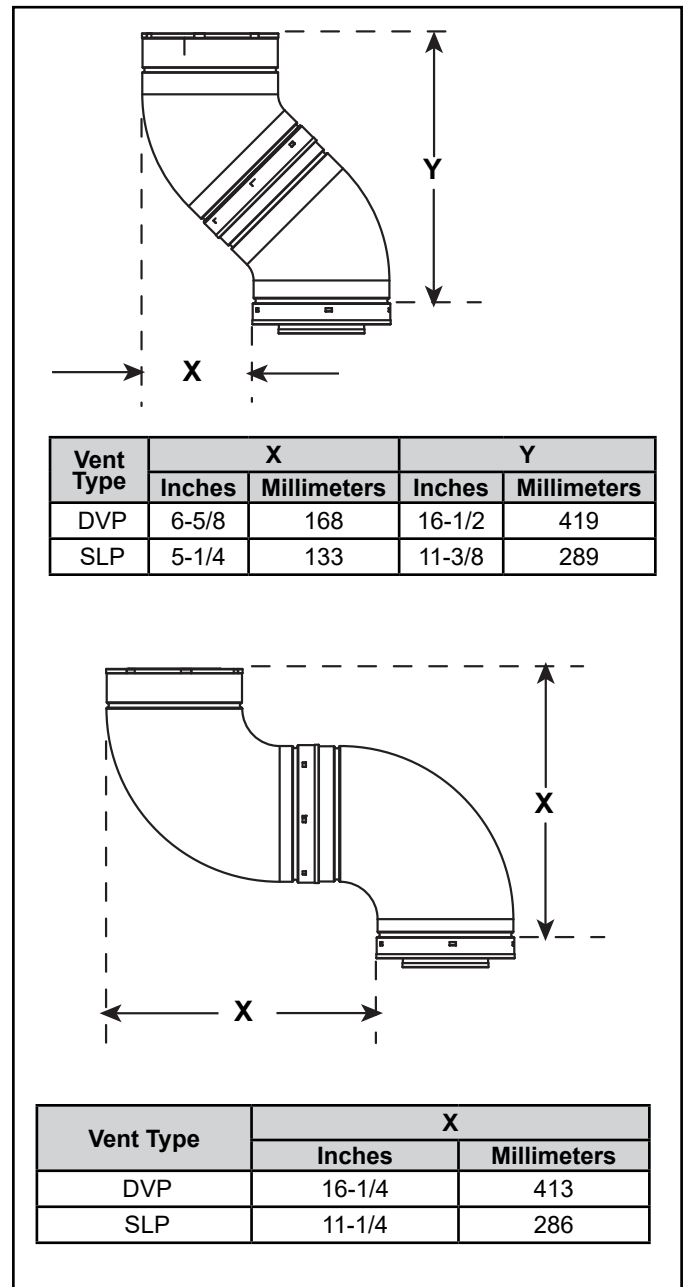

Figure 4.6 Vertical and Horizontal Offset for DVP and SLP Elbows

## E. Measuring Standards

Vertical and horizontal measurements listed in the vent diagrams were made using the following standards:

- Pipe measurements are shown using the effective length of pipe. See Section 12.A (Figure 12.1 for DVP, Figure 12.8 for SLP) for information on effective length of pipe components.
- Horizontal terminations are measured to the outside mounting surface (flange of termination cap) (see Figure 4.7).
- Vertical terminations are measured to top of last section of pipe. See Figure 4.8.
- Horizontal pipe installed level with no rise.

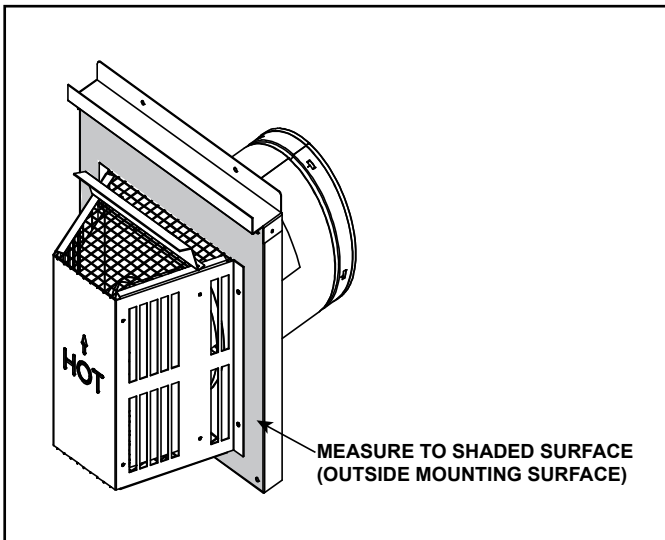

Figure 4.7 Measure to Outside Mounting Surface

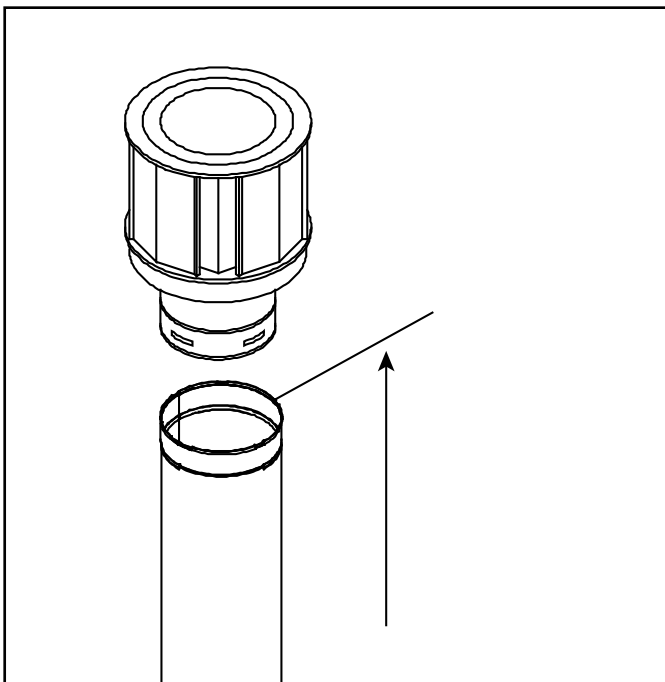

Figure 4.8 Measure to Top of Last Section of Pipe

## F. Vent Diagrams

### General Rules:

- SUBTRACT 3 ft. from the total H measurement for each 90° elbow installed horizontally.
- SUBTRACT 1-1/2 ft. from the total H measurement for each 45° elbow installed horizontally.
- A maximum of three 90° elbows (or six 45° elbows) may be used in any vent configuration. Some elbows may be installed horizontally. See Figure 4.18.
- Elbows may be placed back to back anywhere in the system.
- Any 90° elbow may be replaced with two back to back 45° elbows.
- When penetrating a combustable wall, a wall shield firestop must be installed.
- When penetrating a combustable ceiling, a ceiling firestop must be installed.
- Horizontal runs of vent do not require vertical rise; horizontal runs may be level.
- Horizontal termination cap should have a 1/4 inch downward slant to allow any moisture in cap to be released. See Figure 4.9.

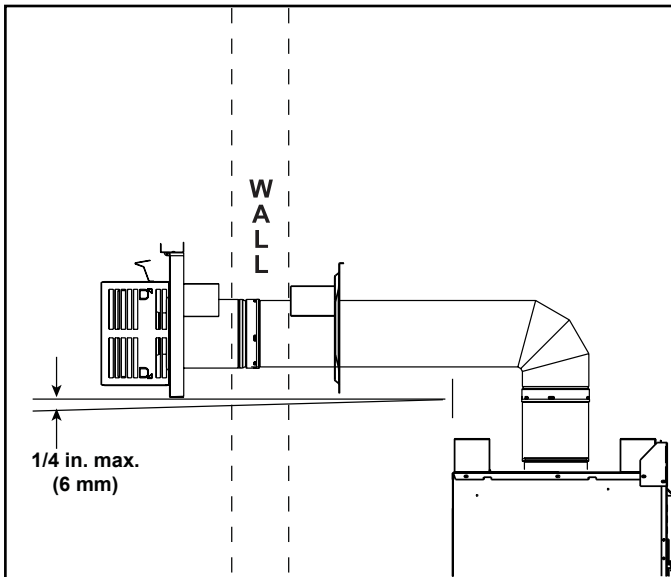

Figure 4.9

**Note: The 6000/8000 series fireplaces can adapt to SLP series vent pipe, if desired.**

When venting off the top of the unit, use a DVP-2SL adapter and a minimum 48 inch vertical section of SLP series vent pipe.

A DVP-SLP24 adapter may also be used with a 24 inch vertical section of SLP series vent pipe.

**After** the 48 inch vertical section, the venting table rules must be followed. The first 48 inch **vertical** section is **NOT** counted as part of the vertical components in the table. It is still counted as part of the overall maximum run. All venting table rules for the vent run must still be followed.

**Example:** DVP pipe 3 ft. min. vertical = 11 ft. max. horizontal  
SLP pipe 7 ft. min. vertical = 11 ft. max. horizontal

### **WARNING**



Fire Risk. Explosion Risk.

Do NOT pack insulation or other combustibles between ceiling firestops.

- ALWAYS maintain specified clearances around venting and firestop systems.



- Install wall shield and ceiling firestops as specified.

Failure to keep insulation or other material away from vent pipe may cause fire.

## Top Vent - Horizontal Termination

### One Elbow

6000CMOD-IFT			
V <sub>1</sub> Minimum		H <sub>1</sub> Maximum	
Elbow Only		Not Allowed	
6 in.	152 mm	7 in.	178 mm
1 ft.	305 mm	11 in.	279 mm
1-1/2 ft.	457 mm	10 ft.	3.0 m
2 ft.	610 mm	15 ft.	4.6 m
2-1/2 ft.	762 mm	18 ft.	5.5 m
3 ft.	914 mm	20 ft.	6.1 m
V <sub>1</sub> + H <sub>1</sub> = 40 ft. (12.2 m) Maximum H <sub>1</sub> = 20 ft. (6.1 m) Maximum			

**WARNING! Risk of Fire!** Elbow heat shield required when V<sub>1</sub> = 2 ft. or less. Clearances to combustibles must be maintained. See Section 5.A.

8000CMOD-IFT			
V <sub>1</sub> Minimum		H <sub>1</sub> Maximum	
Elbow Only		Not Allowed	
6 in.	152 mm	2 ft.	610 mm
1 ft.	305 mm	3 ft.	914 mm
2 ft.	610 mm	6 ft.	1.8 m
3 ft.	914 mm	11 ft.	3.4 m
4 ft.	1.2 m	20 ft.	6.1 m
V <sub>1</sub> + H <sub>1</sub> = 40 ft. (12.2 m) Maximum H <sub>1</sub> = 20 ft. (6.1 m) Maximum			

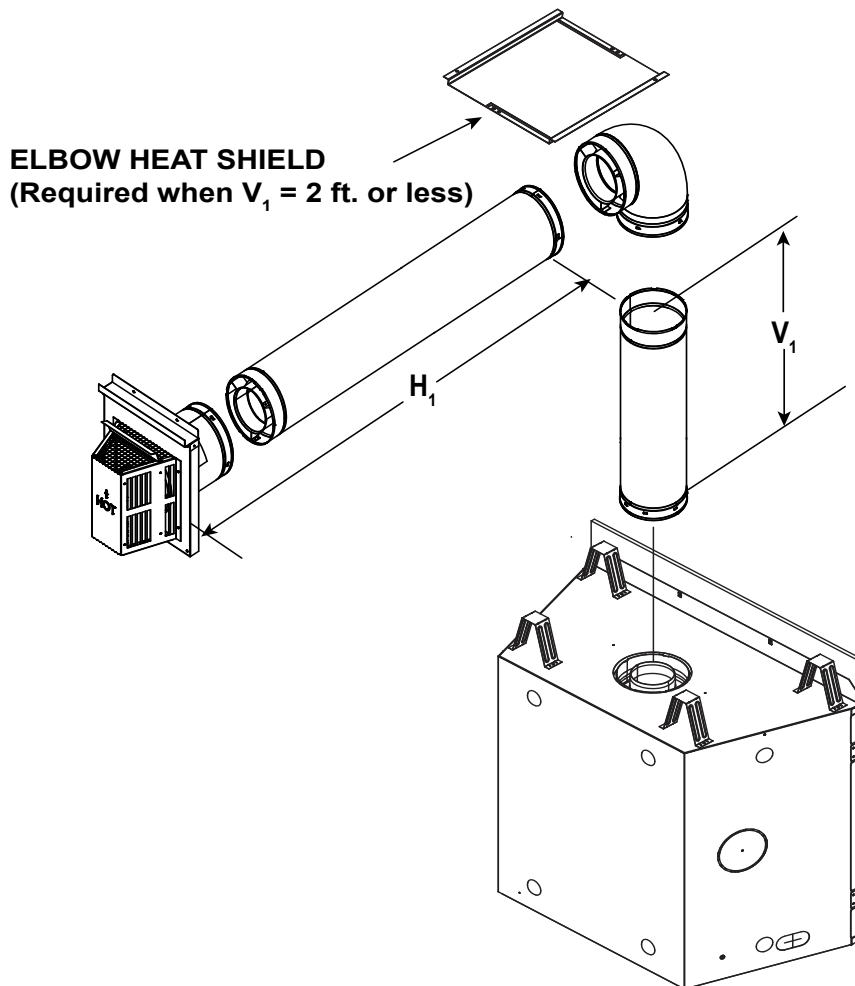

Figure 4.10

# Top Vent - Horizontal Termination - (continued)

## Two Elbows

6000CMOD-IFT			
V <sub>1</sub> Minimum		H <sub>1</sub> + H <sub>2</sub> Maximum	
Elbow only		Not Allowed	
6 in.	152 mm	Not Allowed	
1 ft.	305 mm	4 ft.	1.2 m
1-1/2 ft.	457 mm	11 ft.	3.4 m
2 ft.	610 mm	17 ft.	5.2 m
2-1/2 ft.	762 mm	20 ft.	6.1 m
V <sub>1</sub> + H <sub>1</sub> + H <sub>2</sub> = 40 ft. (12.2 m) Maximum H <sub>1</sub> + H <sub>2</sub> = 20 ft. (6.1 m) Maximum V <sub>1</sub> = 1 ft. (305 mm) Minimum			

8000CMOD-IFT			
V <sub>1</sub> Minimum		H <sub>1</sub> + H <sub>2</sub> Maximum	
Elbow only		Not Allowed	
6 in.	152 mm	Not Allowed	
1 ft.	305 mm	2 ft.	610 mm
2 ft.	610 mm	4 ft.	1.2 m
3 ft.	914 mm	6 ft.	1.8 m
4 ft.	1.2 m	8 ft.	2.4 m
6 ft.	1.8 m	12 ft.	3.6 m
10 ft.	3.0 m	20 ft.	6.1 m
V <sub>1</sub> + H <sub>1</sub> + H <sub>2</sub> = 40 ft. (12.2 m) Maximum H <sub>1</sub> + H <sub>2</sub> = 20 ft. (6.0 m) Maximum V <sub>1</sub> = 1 ft. (305 mm) Minimum			

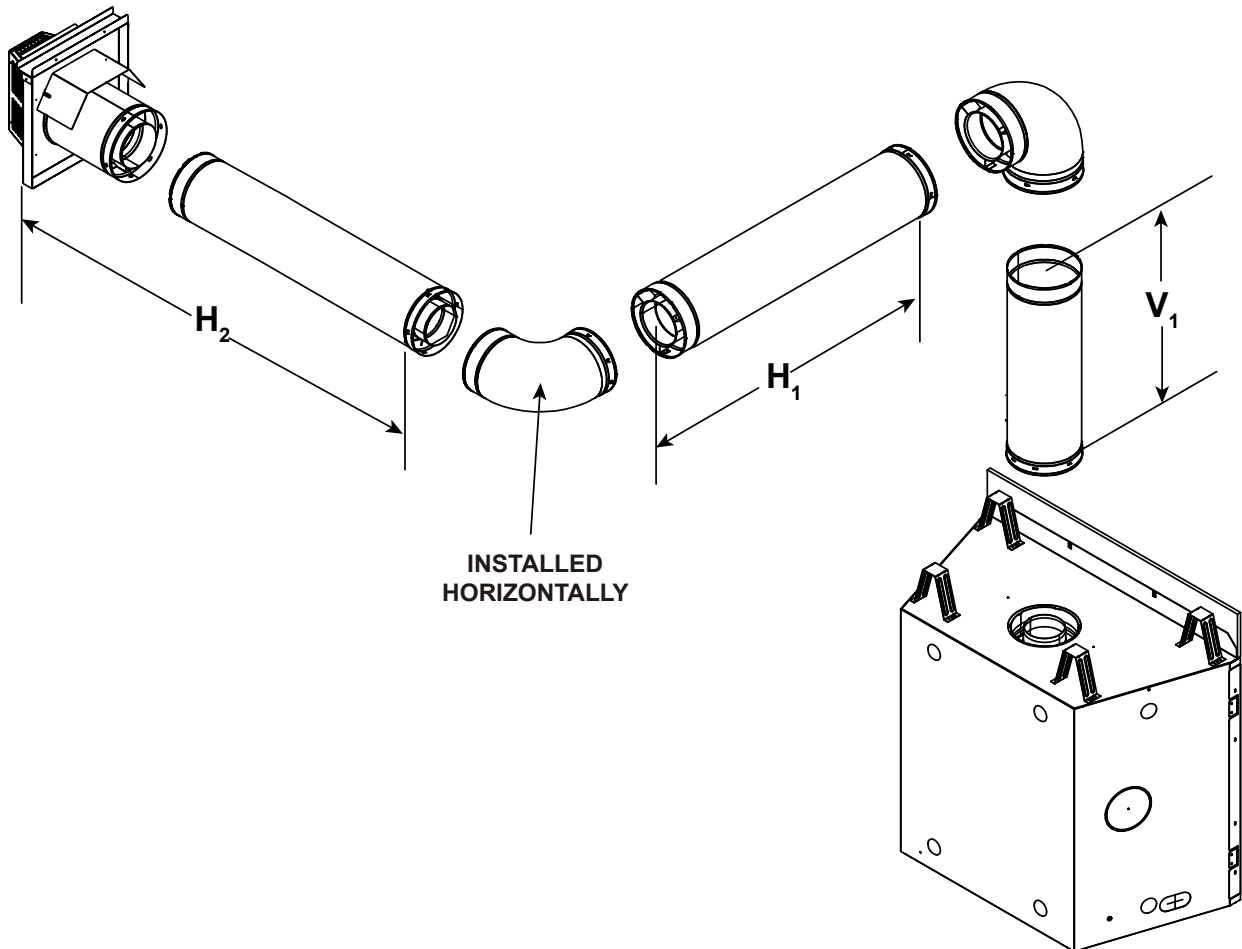

Figure 4.11



## Top Vent - Horizontal Termination - (continued)

### Three Elbows

V <sub>1</sub> Min.		H <sub>1</sub> Max.		V <sub>2</sub> Min.		H <sub>2</sub> Max.	
6 in.	152 mm	3 ft	914 mm	6 in.	152 mm	2 ft.	610 mm
1 ft.	305 mm	6 ft.	1.8 m	1 ft.	305 mm	6 ft.	1.8 m
2 ft.	610 mm	11 ft.*	3.4 m*	2 ft.	610 mm	10 ft.*	3.1 m*
3 ft.	914 mm	16 ft.*	4.9 m*	3 ft.	914 mm	14 ft.*	4.3 m*
*H <sub>1</sub> + H <sub>2</sub> = 20 ft. (6.1 m) Maximum				V <sub>1</sub> + V <sub>2</sub> + H <sub>1</sub> + H <sub>2</sub> = 40 ft. (12.2 m) Maximum			

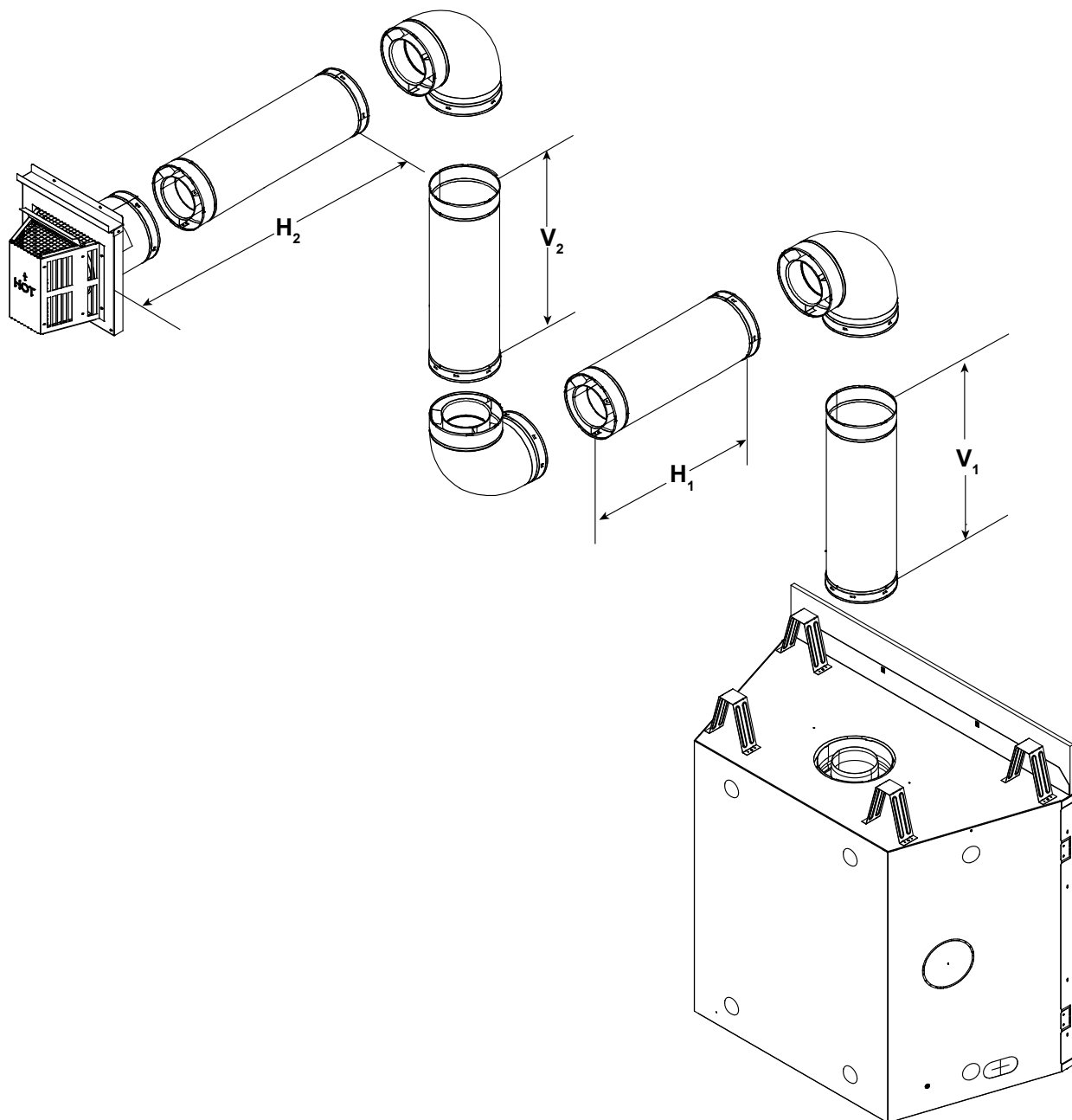

Figure 4.12

## Top Vent - Vertical Termination

### No Elbow

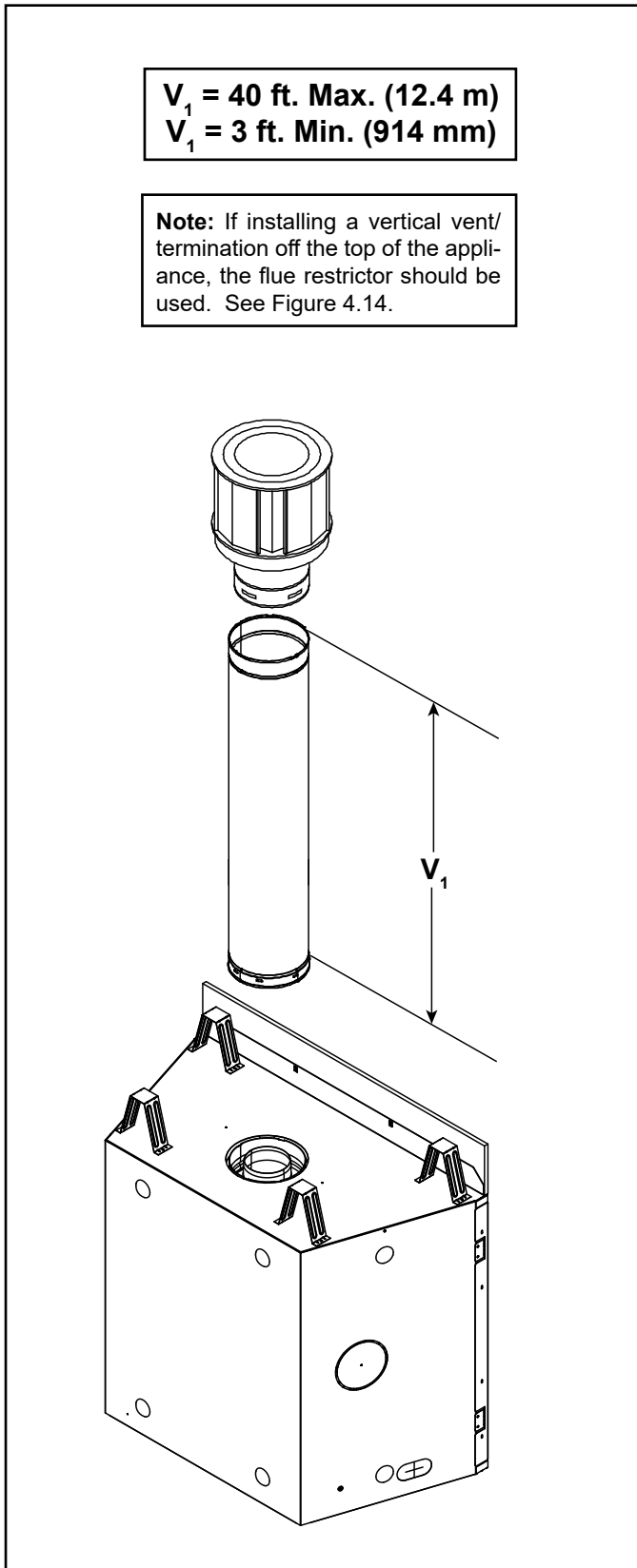

Figure 4.13

## Flue Restrictor Instructions

1. Install flue restrictor as shown below.
2. Orientate and align the two pieces of the flue restrictor as shown in Figure 4.15.

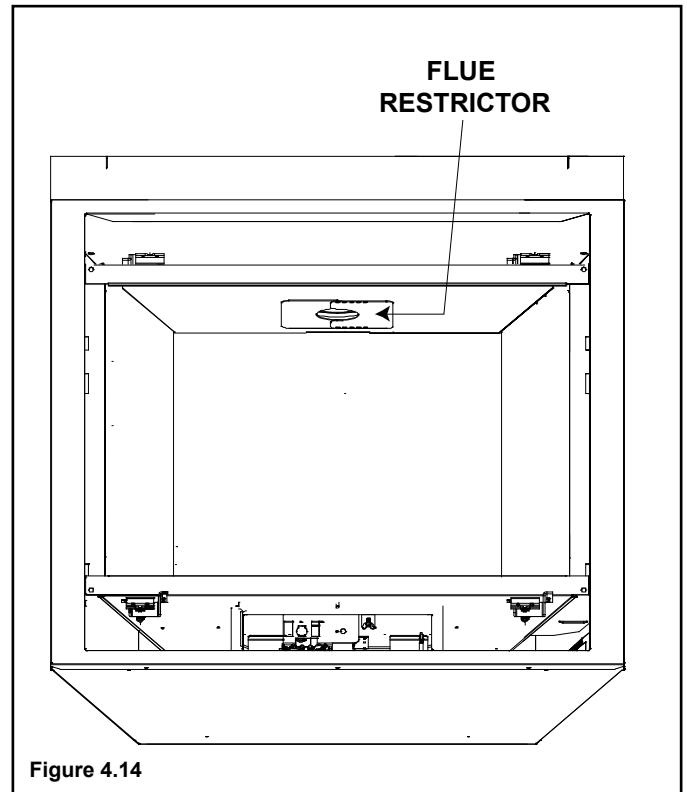

Figure 4.14

3. Match the amount of vertical you have in the system with the chart to find the appropriate position to set the flue restrictor. See Figure 4.15 and 4.16.
4. Center the two flue restrictor pieces on the vent at the setting selected in step 3 and secure in place by using two self-tapping screws. See Figure 4.16.

Vertical	NG
4 ft.	1-1
8 ft.	2-2
15 ft.	3-3
20 ft.	3-3
25 ft.	3-3
30 ft.	3-4
35 ft.	3-4
40 ft.	3-4

Figure 4.15

## Top Vent - Vertical Termination (continued)

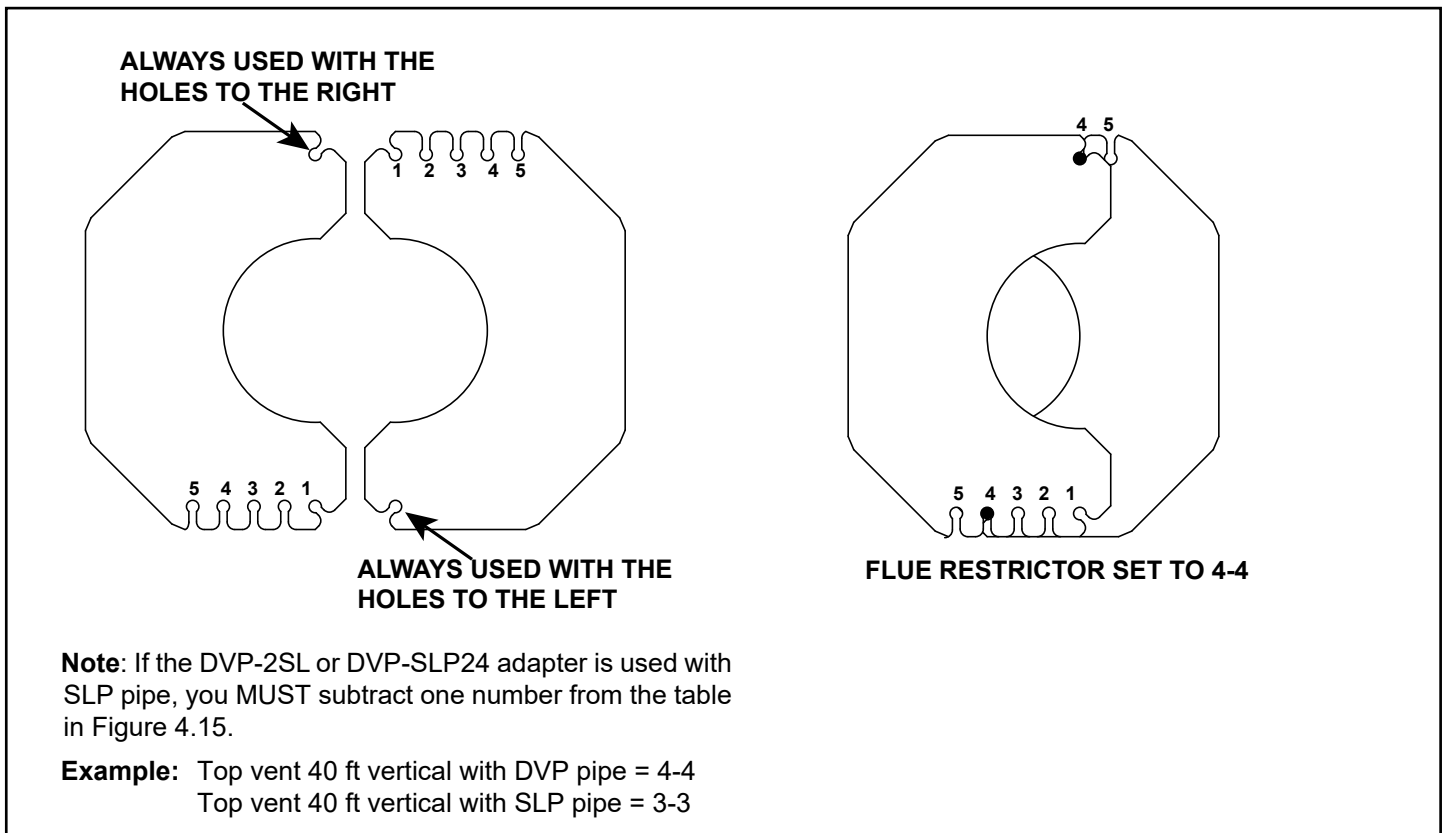

Figure 4.16 Setting the Flue Restrictor

## Two Elbows

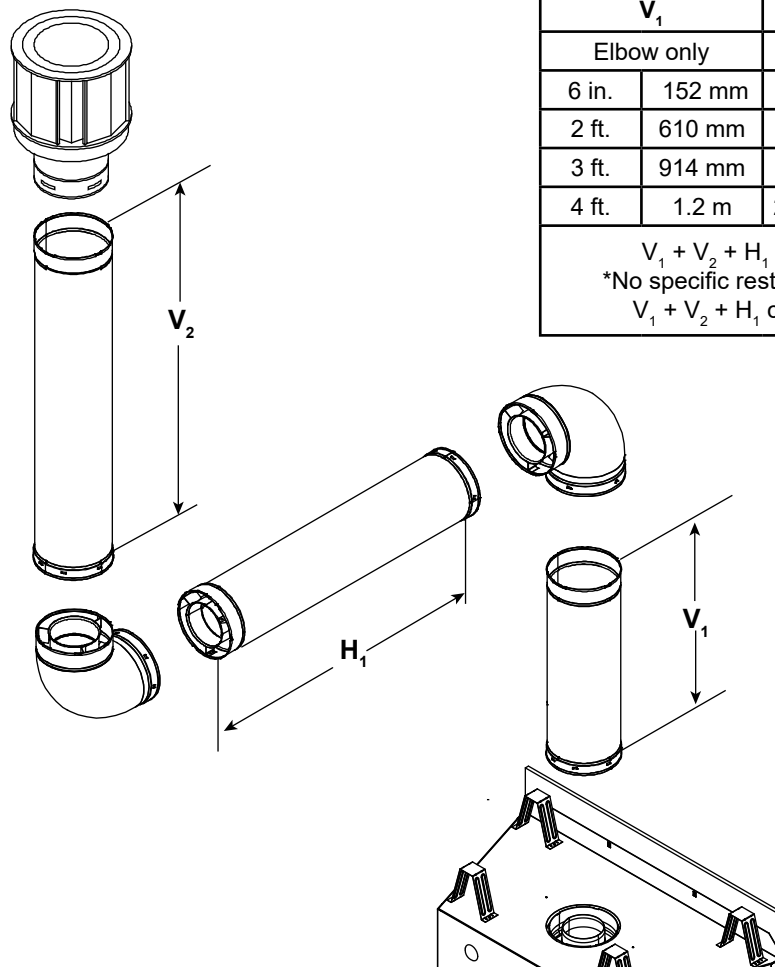
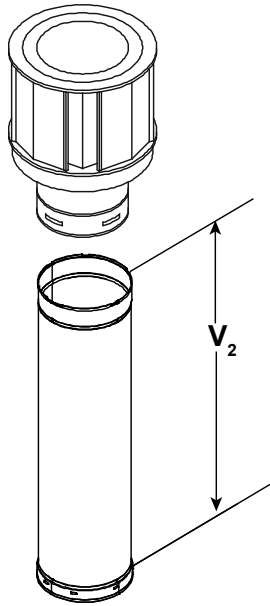

Figure 4.17

# Top Vent - Vertical Termination - (continued)

## Three Elbows



$V_1$		$H_1 + H_2$		$V_2$	$V_1 + V_2$ Minimum			$H_1 + H_2$ Maximum	
Elbow only		1 ft.	305 mm	*	*	*	*	1 ft.	305 mm
6 in.	152 mm	2 ft.	610 mm	*	*	*	2 ft.	610 mm	
1 ft.	305 mm	2 ft.	610 mm	*	*	*	2 ft.	610 mm	
2 ft.	610 mm	4 ft.	1.2 m	*	*	*	4 ft.	1.2 m	
3 ft.	914 mm	9 ft.	2.7 m	*	*	*	9 ft.	2.7 m	
4 ft.	1.2 m	18 ft.	5.5 m	*	*	*	18 ft.	5.5 m	
$H_1 + H_2 = 20$ ft. (6.1 m) Maximum				$V_1 + V_2 + H_1 + H_2 = 40$ ft. (12.2 m) Maximum					

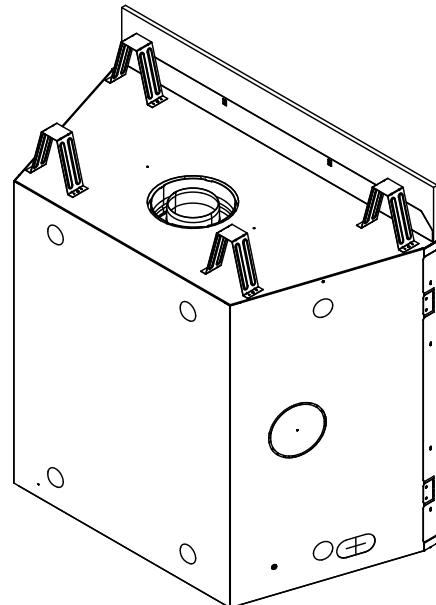
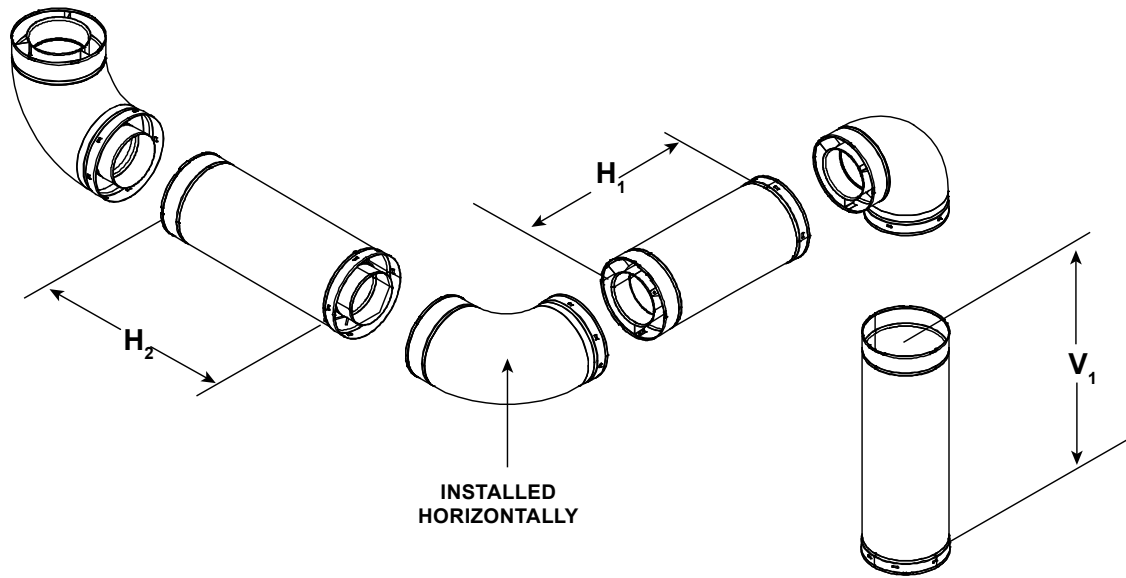

Figure 4.18

# 5 Vent Clearances and Framing

## A. Pipe Clearances to Combustibles

**WARNING! Risk of Fire! Maintain air space clearance to vent. DO NOT pack insulation or other combustibles:**

- Between ceiling firestops
- Between wall shield firestops
- Around vent system

Failure to keep insulation or other material away from vent pipe may cause over heating and fire.

**WARNING! Risk of Fire! Elbow heat shield required when  $V_1 = 2$  ft. or less. Clearances to combustibles must be maintained. See Figure 4.10.**

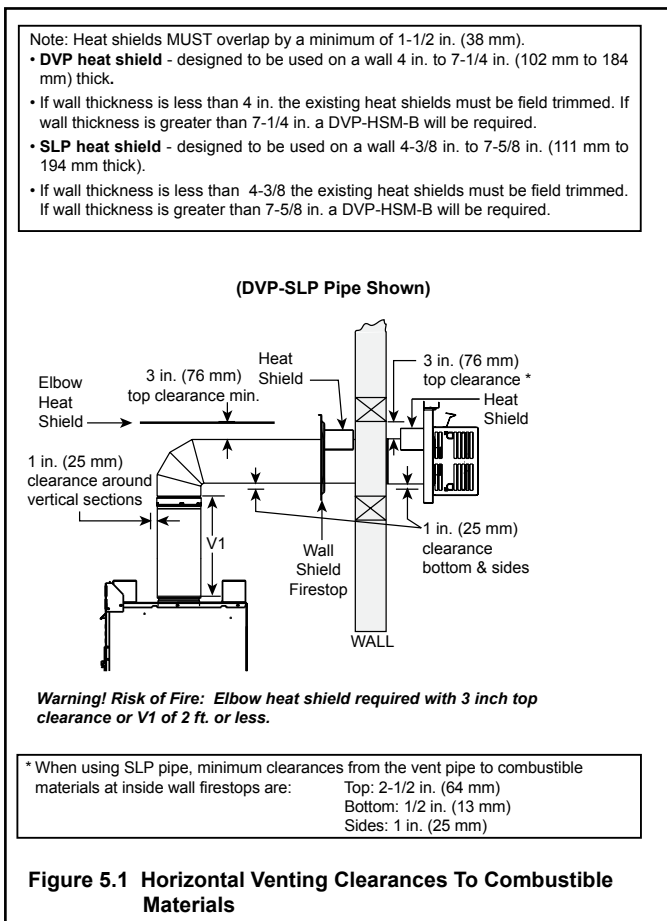

- DVP pipe - A wall shield firestop is required on one side only on interior walls. If your local inspector requires a wall shield firestop on both sides, then both wall shield firestops must have a heat shield (refer to Section 12.A.) attached to them.
- See Section 7.G for information for regarding the installation of a horizontal termination cap.

## Non-Combustible Wall Penetration

If the hole being penetrated is surrounded by noncombustible materials such as concrete, a hole with diameter one inch greater than the pipe is acceptable.

Whenever a non-combustible wall is penetrated, the wall shield firestop is only required on one side and no heat shield is necessary.

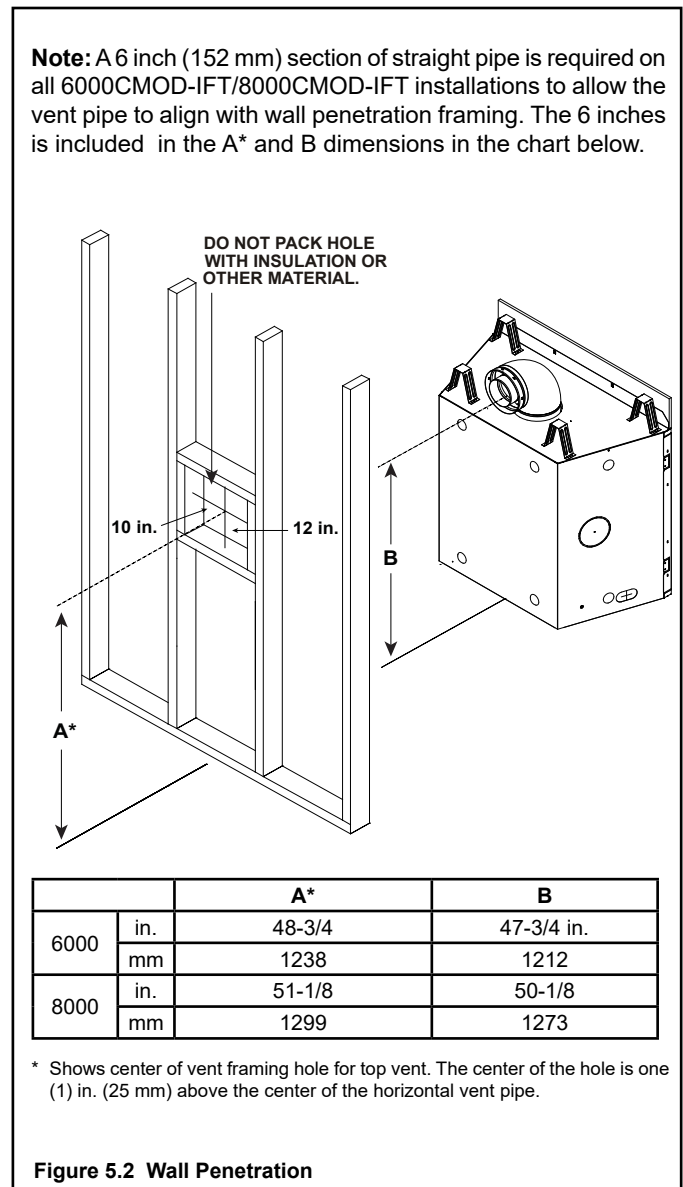

## B. Wall Penetration Framing

### Combustible Wall Penetration

Whenever a combustible wall is penetrated, you must frame a hole for the wall shield firestop(s). The wall shield firestop maintains minimum clearances and prevents cold air infiltration.

- The opening must be framed on all four sides using the same size framing materials as those used in the wall construction.
- SLP pipe - A wall shield firestop must be placed on each side of an interior wall. A minimum 1-1/2 in. (38 mm) overlap of attached heat shields must be maintained.

### C. Ceiling Firestop/Floor Penetration Framing

A ceiling firestop **MUST** be used between floors and attics.

- **DVP pipe only** - Frame an opening 10 in. by 10 in. (254 mm by 254 mm) whenever the vent penetrates a ceiling/floor (see Figure 5.3).
- **SLP pipe only** - Frame opening 9 in. x 9 in. (229 mm x 229 mm) whenever the vent penetrates a ceiling/floor (see Figure 5.3).
- Frame the area with the same sized lumber as used in ceiling/floor joist.
- The ceiling firestop may be installed above or below the ceiling joists when installed with an attic insulation shield. It must be under joists between floors that are not insulated. Refer to Figure 5.4.
- Secure in place with nails or screws.

**WARNING! Risk of Fire! DO NOT pack insulation around the vent. Insulation must be kept back from the pipe to prevent overheating.**

### D. Install Attic Insulation Shield

**WARNING! Fire Risk. DO NOT allow loose materials or insulation to touch vent. Hearth & Home Technologies requires the use of an attic shield.**

The International Fuel Gas Code requires an attic shield constructed of 26 gauge minimum steel that extends at least 2 in. (51 mm) above insulation.

- Attic insulation shields must meet specified clearances to combustibles and be secured in place.
- An attic insulation shield kit is available from Hearth & Home Technologies. Contact your dealer to order. Install attic insulation shield according to instructions included with kit.

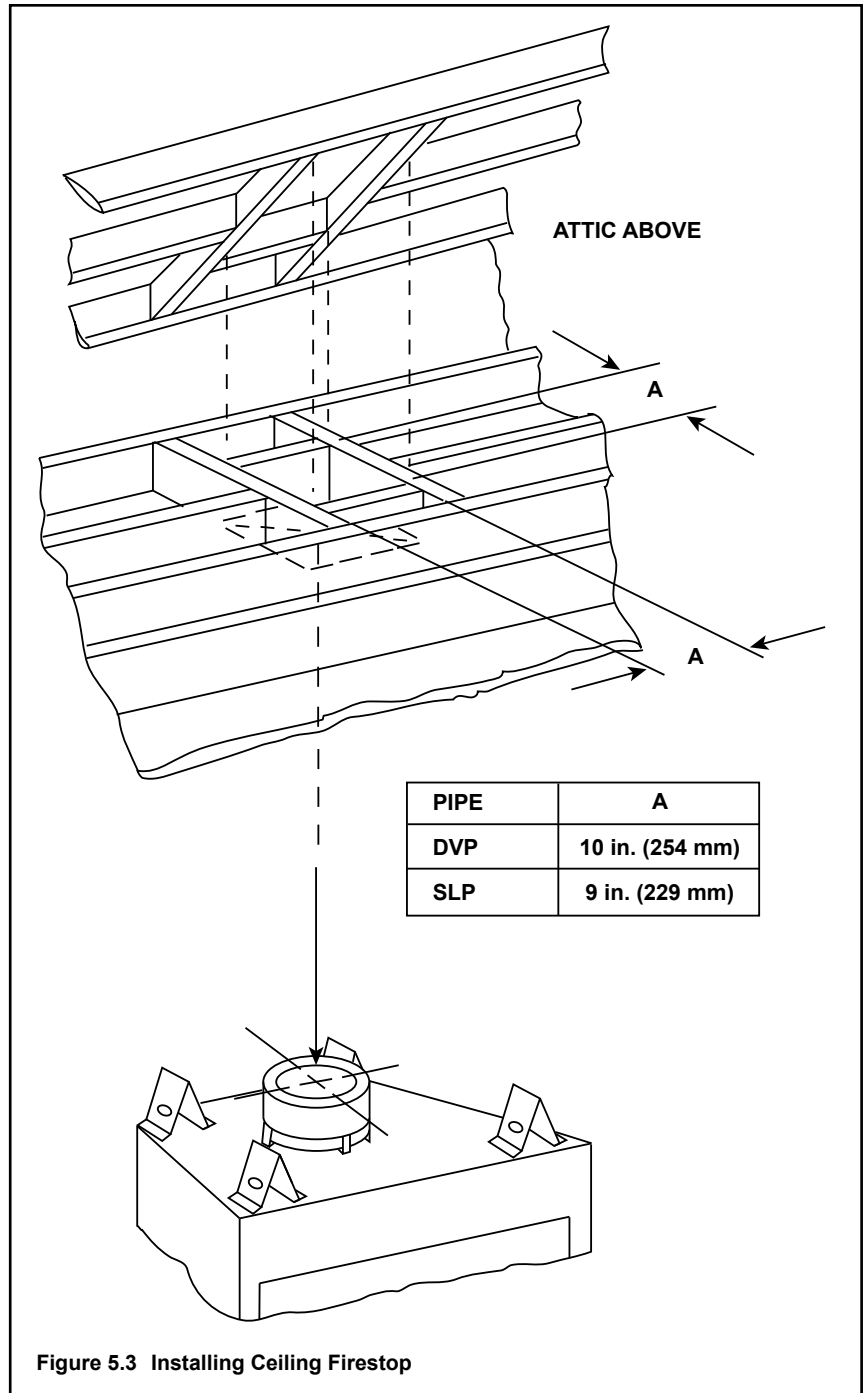

Figure 5.3 Installing Ceiling Firestop

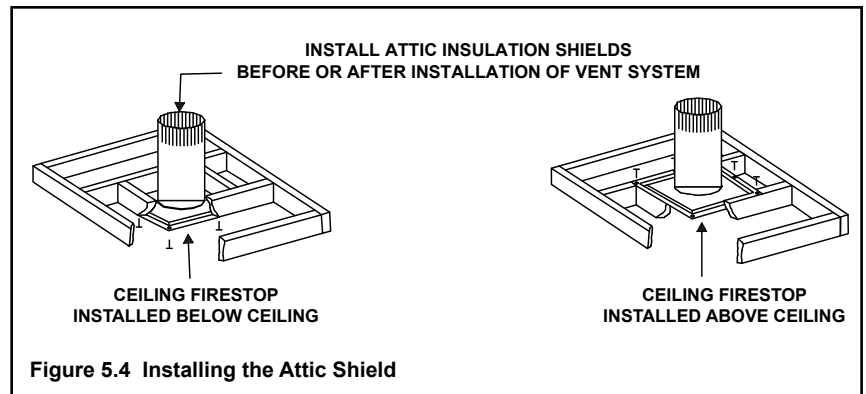

Figure 5.4 Installing the Attic Shield

# 6 Appliance Preparation

## A. Vent Collar Preparation

**CAUTION! Risk of Cuts, Abrasions or Flying Debris.** Wear protective gloves and safety glasses during installation. Sheet metal edges are sharp.



Figure 6.1 Seal Cap in Position (Generic Fireplace Shown)



Figure 6.2 Remove the seal cap. (Generic Fireplace Shown)

**WARNING! Risk of Fire! DO NOT remove the installed piece of insulation from the firebox top on 8000CMOD-IFT models. Overheating will occur.**

1. Remove the seal cap as shown in Figure 6.2.
2. Locate the fiberglass gasket in the manual bag. Attach the gasket to the outer wrap using two self-tapping screws. This creates a seal between the first vent component and the outer fireplace wrap. Figure 6.3 shows the gasket in place.
3. Secure the first section of venting to the firebox by attaching to the starting collar with screws. See Figure 6.4.

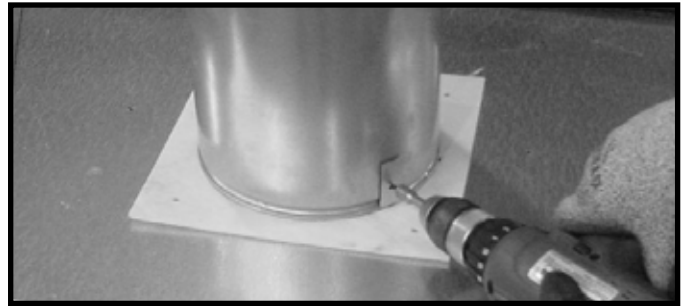

Figure 6.3 Gasket in Place (Generic Fireplace Shown)

**Note:** Vent attachment method varies by model.

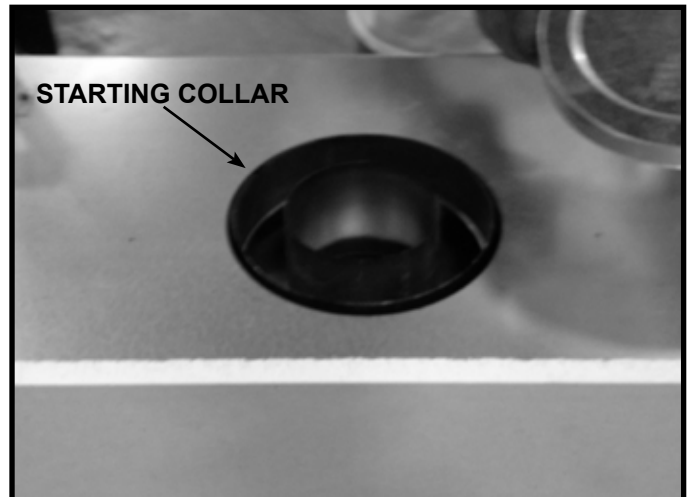

Figure 6.4 Starting Collar (Generic Fireplace Shown)

## B. Installing Optional Heat Management Systems

**NOTICE:** Additional clearances are required for heat management systems installations. Provisions must be made in advance to ensure fit within the framing.

- Locate the heat management ports on the left and right sides of the appliance. Either one or two Heat-Zone® -Gas Kits may be installed. Remove the knock-out from the fireplace and discard it. See Figure 6.5.
- Center the duct collar around the exposed hole and attach it to the fireplace with 3 screws.

**Note:** Do this BEFORE final positioning of fireplace.

- Determine the location for the air register/fan housing assembly.

Reference the appropriate instructions included with the kit for the remaining installation steps.

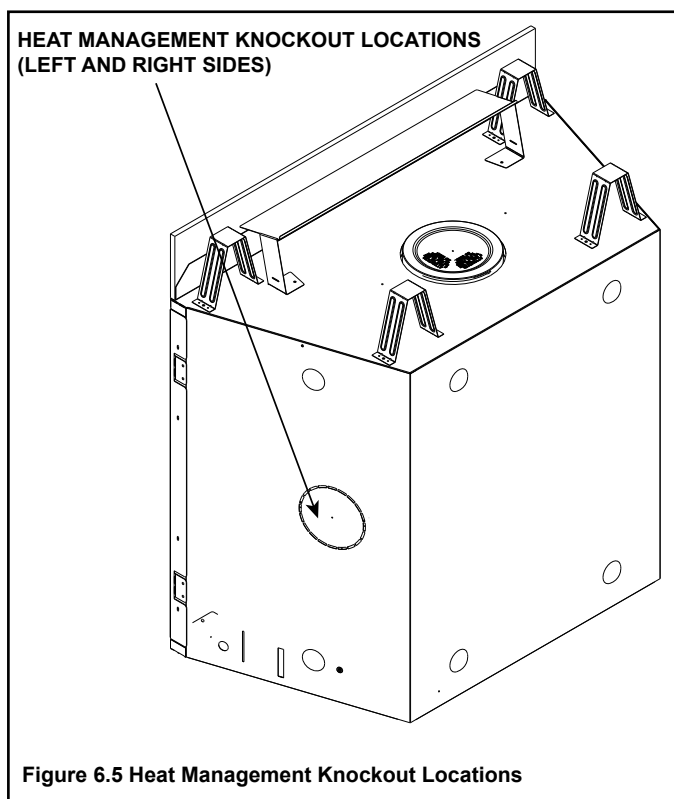



## C. Securing and Leveling the Appliance

**WARNING! Risk of Fire!** Prevent contact with:

- Sagging or loose insulation
- Insulation backing or plastic
- Framing and other combustible materials

Block openings into the chase to prevent entry of blown-in insulation. Make sure insulation and other materials are secured.

**DO NOT** notch the framing around the appliance standoffs.

Failure to maintain air space clearance could cause overheating and fire.

The diagram shows how to properly square and position, and secure the appliance. See Figures 6.6 and 6.7. Nailing tabs are provided to secure the appliance to the framing members.

- Bend out nailing tabs on each side.
- Place the appliance into position.
- Keep nailing tabs flush with the framing.
- Level the appliance from side to side and front to back.
- “Square” the unit by securing diagonal dimensions to within 1/4 inch of each other. See Figure 6.6.
- Shim the appliance as necessary. It is acceptable to use wood shims underneath the appliance.
- Secure the appliance to the framing by using nails or screws through the nailing tabs.
- Optional: Secure the appliance to the floor by inserting two screws through the pilot holes at the bottom of the appliance.

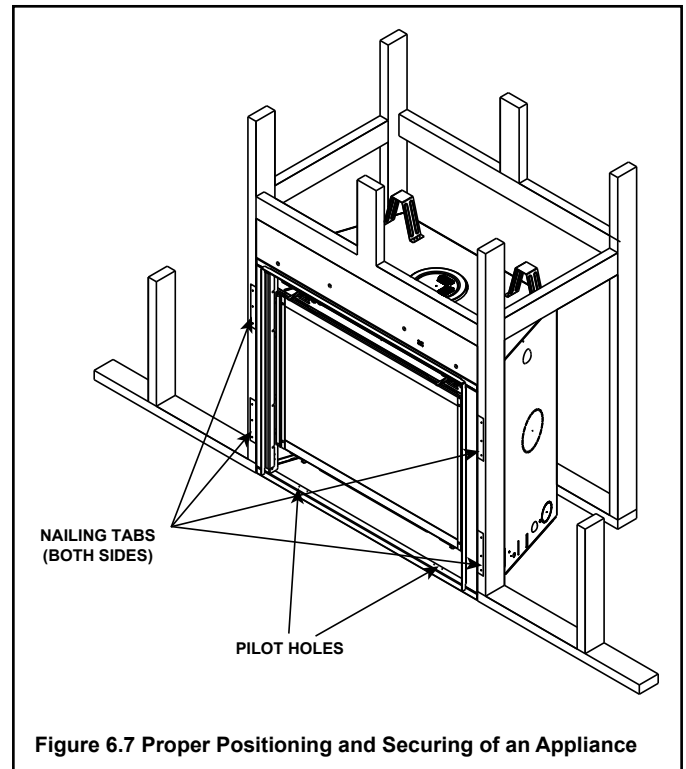
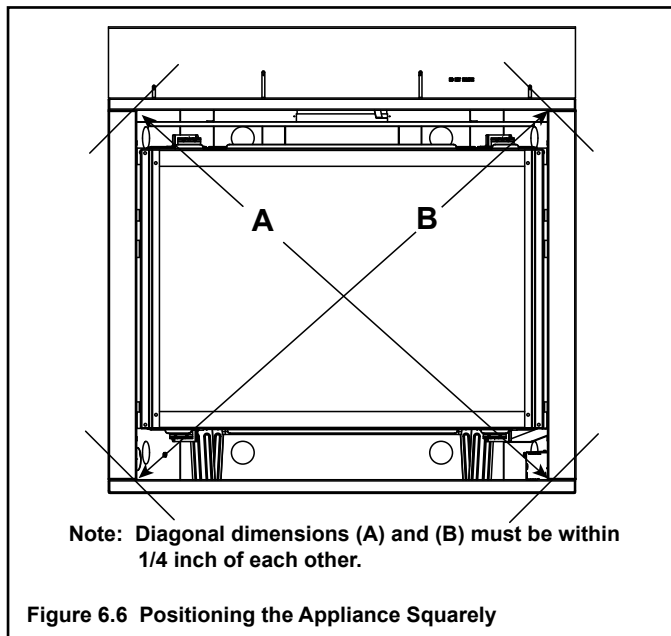

## D. Installing the Non-combustible Board

The factory supplied non-combustible board spans the distance from the top of the fireplace to the center of the framing header. This board must be used. See Figure 6.8.

**WARNING! Risk of Fire!** Non-combustible board must be installed across the top of the fireplace per Figure 6.8.

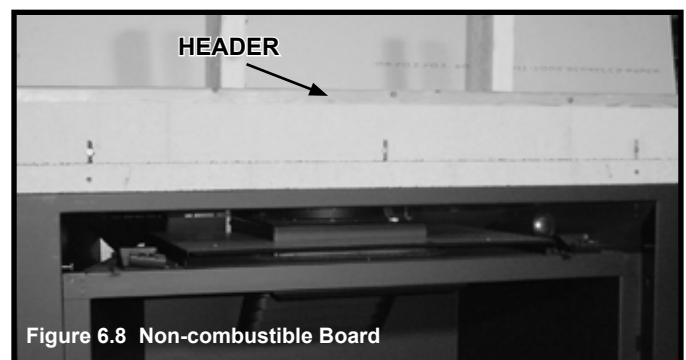

# 7 Venting and Chimneys

## A. Assemble Vent Sections (DVP Pipe)

### Attach Vent to the Firebox Assembly

**Note:** The end of the pipe sections with the lanced tabs will face toward the appliance.

Attach the first pipe section to the starting collar:

- Lanced pipe end of the starting collar.
- Inner pipe over inner collar.
- Push the pipe section until all lanced tabs snap in place.
- Lightly tug on pipe to confirm it has locked.

### Required Commercial, Multi-family (Multi-level exceeding two stories), or High-Rise Applications

All outer pipe joints must be sealed with 100% silicone (300 °F minimum continuous exposure rating), including the slip section that connects directly to the horizontal termination cap.

- Apply a bead of silicone sealant (300 °F minimum continuous exposure rating) inside the female outer pipe joint prior to joining sections. See Figure 7.1. **OR**

Apply a bead of silicone sealant (300 °F minimum continuous exposure rating) to the outside of connecting joint after joining sections **OR**

Apply aluminum foil tape (300 °F minimum continuous exposure rating) to the outside of connecting joint after joining sections. On horizontal pipe runs, it is recommended that the tape seam is positioned on the bottom side of the vent pipe.

- Only outer pipes need to be sealed. All unit collar, pipe, slip section, elbow and cap outer flues shall be sealed in this manner, unless otherwise stated.

**WARNING! Risk of Fire or Explosion! DO NOT break silicone seals on slip sections. Use care when removing termination cap from slip pipe. If slip section seals are broken during removal of the termination cap, vent could leak.**

### Assemble Pipe Sections

Per Figure 7.2:

- Start the inner pipe on the lanced end of section A into the flared end of section B.
- Start the outer pipe of section A over the outer pipe of section B.
- Once both vents sections are started, push firmly until all lanced tabs lock into place.
- Lightly tug on the pipe to confirm the tabs have locked.

It is acceptable to use screws no longer than 1/2 in. (13 mm) to hold outer pipe sections together. If predrilling holes, **DO NOT** penetrate inner pipe.

For 90° and 45° elbows that are changing the vent direction

from horizontal to vertical, one screw minimum should be put in the outer flue at the horizontal elbow joint to prevent the elbow from rotating. Use screws no longer than 1/2 in. (13 mm). If predrilling screw holes, **DO NOT** penetrate inner pipe.



Figure 7.1 High Temperature Silicone Sealant

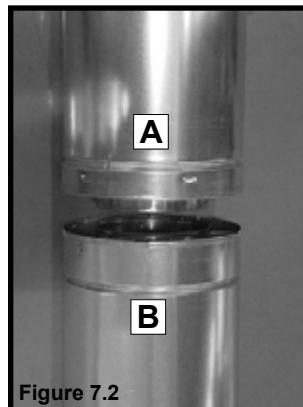

Figure 7.2

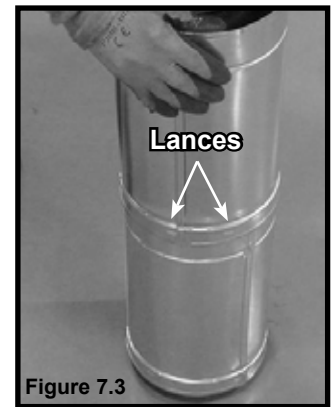
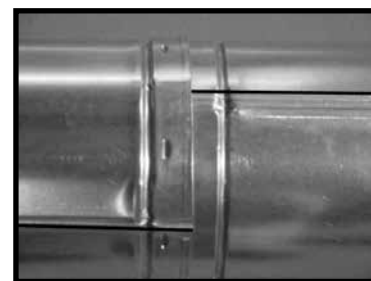
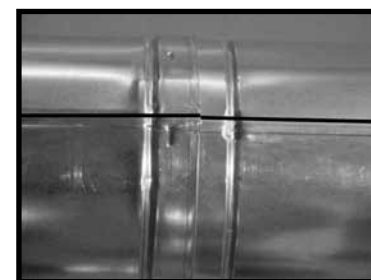

Figure 7.3

**Note:** Make sure that the seams are not aligned to prevent unintentional disconnection.



CORRECT



INCORRECT

Figure 7.4 Seams

## B . Assemble Vent Sections (SLP Pipe)

To attach the first vent component to the starting collars of the appliance:

- Attach a DVP-2SL or DVP-SLP24 adapter to the starting collar of the appliance.
- Lock the vent components into place by sliding the pipe section onto the collar.
- Align the seam of the pipe and seam of collar to allow engagement. Rotate the vent component to lock into place. Use this procedure for all vent components. See Figure 7.5.
- Slide the gasket over the first vent section and place it flush to the appliance. This will prevent cold air infiltration. Caulk with a minimum of 300 °F continuous exposure rating may be used to hold the part in place.
- Continue adding vent components, locking each succeeding component into place.
- Ensure that each succeeding vent component is securely fitted and locked into the preceding component.

It is acceptable to use screws no longer than 1/2 in. (13 mm) to hold outer pipe sections together. If predrilling holes, **DO NOT** penetrate inner pipe.

### Required Commercial, Multi-family (Multi-level exceeding two stories), or High-Rise Applications

All outer pipe joints must be sealed with high temperature silicone (300 °F minimum continuous exposure rating), including the slip section that connects directly to the horizontal termination cap.

- Apply a bead of silicone sealant (300 °F minimum continuous exposure rating) inside the female outer pipe joint prior to joining sections. See Figure 7.1. **OR**

Apply a bead of silicone sealant (300 °F minimum continuous exposure rating) to the outside of connecting joint after joining sections **OR**

Apply aluminum foil tape (300 °F minimum continuous exposure rating) to the outside of connecting joint after joining sections. On horizontal pipe runs, it is recommended that the tape seam is positioned on the bottom side of the vent pipe.

- Only outer pipes need to be sealed. All unit collar, pipe, slip section, elbow and cap outer flues shall be sealed in this manner, unless otherwise stated.

**WARNING! Risk of Fire or Explosion! DO NOT break silicone seals on slip sections. Use care when removing termination cap from slip pipe. If slip section seals are broken during removal of the termination cap, vent could leak.**

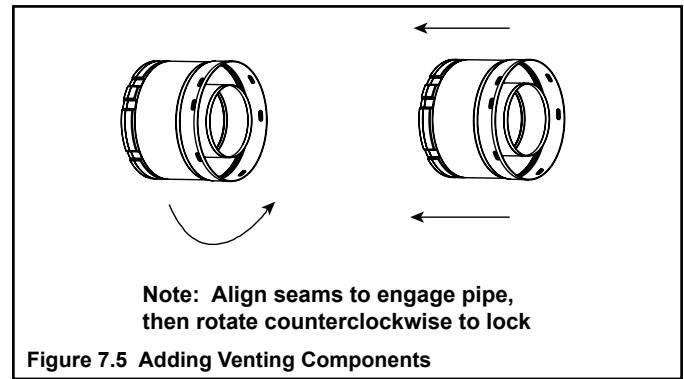

## C. Assemble Slip Sections

- Slide the inner flue of the slip section into the inner flue of the pipe section and the outer flue of the slip section over the outer flue of the pipe section. See Figure 7.6.
- Slide together to the desired length.

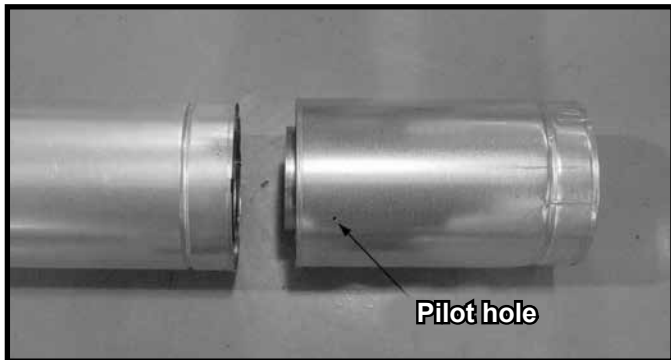

Figure 7.6 Slip Section Pilot Holes

- Maintain a 1-1/2 in. (38 mm) overlap between the slip section and the pipe section.
- Secure the pipe and slip section with two screws no longer than 1/2 in. (13 mm), using the pilot holes in the slip section. See Figure 7.7.

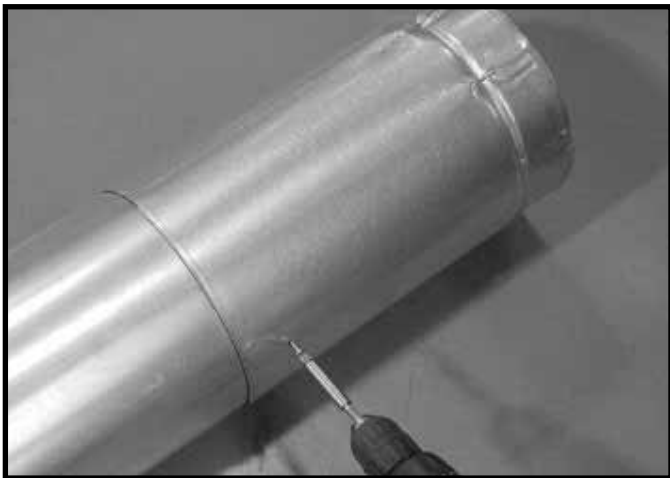

Figure 7.7 Screws into Slip Section

- Continue adding pipe as necessary following instructions in “Assembling Pipe Sections.”

**NOTICE:** If slip section is too long, the inner and outer flues of the slip section can be cut to the desired length.

**NOTICE:** When installing a vent system with an HRC termination cap, all pipe system joints shall be sealed using a high temperature silicone sealant (300 °F minimum continuous exposure rating).

- Apply a bead of silicone sealant (300 °F minimum continuous exposure rating) inside the female outer pipe joint prior to joining sections.
- Only outer pipes are sealed, sealing the inner flue is not required.
- All unit collar, pipe, slip section, elbow and cap outer flues shall be sealed.

## D. Secure the Vent Sections

- Vertical runs originating off the top of the appliance, with no offsets, must be supported every 8 ft. (2.44 m) after the maximum allowed 25 ft. (7.62 m) of unsupported rise.
- Vertical runs originating off the rear of the appliance, or after any elbow, must be supported every 8 ft. (2.44 m).
- Horizontal runs must be supported every 5 feet (1.52 m).
- Vent supports or plumbers strap (spaced 120° apart) may be used to support vent sections. See Figures 7.8 and 7.9.
- Wall shield firestops may be used to provide horizontal support to vent sections.
- SLP ceiling firestops have tabs that may be used to provide vertical support.

**WARNING! Risk of Fire, Explosion or Asphyxiation!** Improper support could allow vent to sag and separate. Use vent run supports and connect vent sections per installation instructions. **DO NOT** allow vent to sag below connection point to appliance.

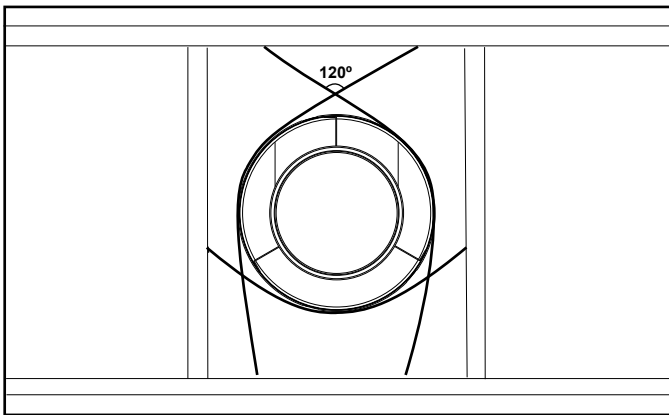

Figure 7.8 Securing Vertical Pipe Sections

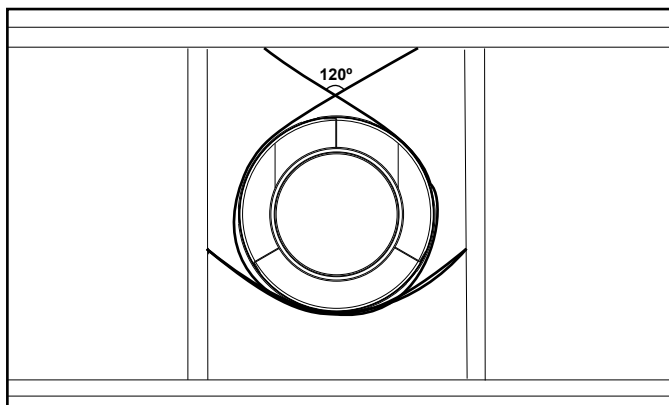

Figure 7.9 Securing Horizontal Pipe Sections

## E. Disassemble Vent Sections

- Rotate either section (see Figure 7.10) so the seams on both pipe sections are aligned as shown in Figure 7.11.
- Pull carefully to separate the pieces of pipe.

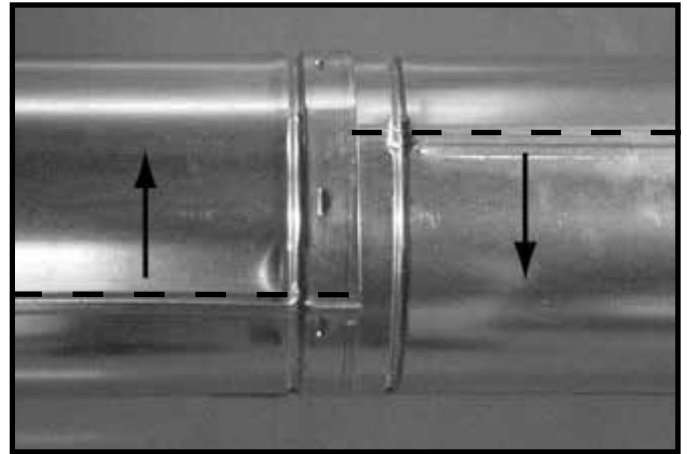

Figure 7.10 Rotate Seams for Disassembly

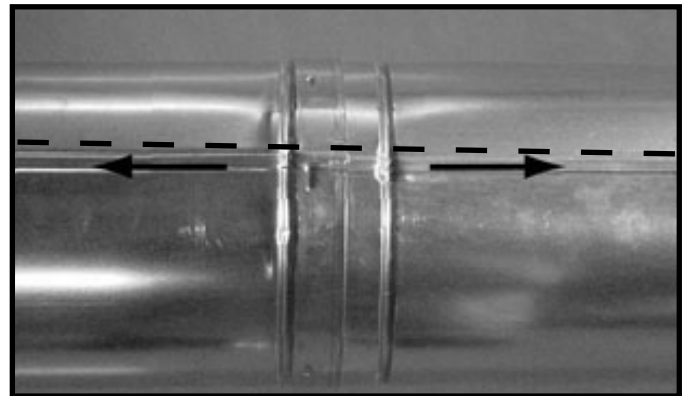

Figure 7.11 Align and Disassemble Vent Sections

## F. Vertical Termination Requirements

### Install Metal Roof Flashing

- See minimum vent heights for various pitched roofs (Figure 7.12) to determine the length of pipe to extend through the roof.
- Slide the roof flashing over the pipe sections extending through the roof as shown in Figure 7.13.

**Note:** When installing a silicone or EPDM pipe flashing boot on a metal roof, it is recommended to put a bead of 100% silicone sealant where the boot contacts the vent pipe to prevent the entry of water. Follow the manufacturer's recommendations when installing the boot. Climate regions with frequent temperatures below - 50 °F (-45.6 °C) should use a silicone flashing boot.

**NOTICE:** Failure to properly caulk the roof flashing and pipe seams could permit entry of water.

- Caulk the gap between the roof flashing and the outside diameter of the pipe.
- Caulk the perimeter of the flashing where it contacts the roof surface. See Figure 7.13.
- Caulk the overlap seam of any exposed pipe sections that are located above the roof line.

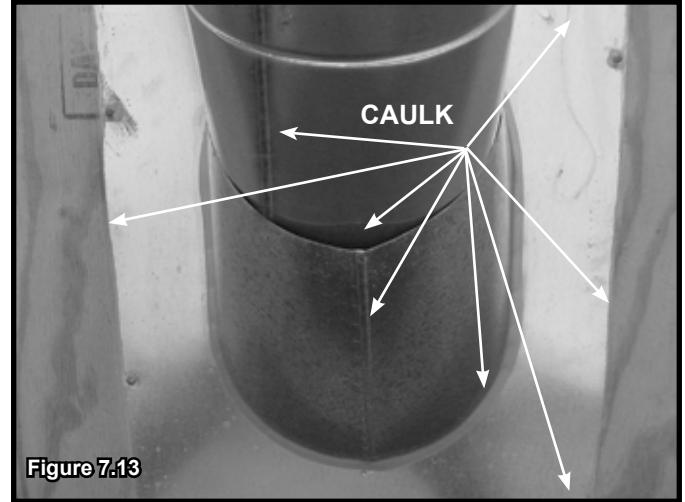

Figure 7.13

### Assemble and Install Storm Collar

**CAUTION! Risk of Cuts, Abrasions or Flying Debris.** Wear protective gloves and safety glasses during installation. Sheet metal edges are sharp.

- Slide the storm collar onto the exposed pipe section and align brackets.
- Insert a bolt (provided) through the brackets and install nut. Do not completely tighten.



Figure 7.14 Insert Bolt into Brackets

- Slide the assembled storm collar down the pipe section until it rests on the roof flashing (see Figure 7.14).
- Tighten nut and make sure the collar is tight against the pipe section.
- Caulk around the top of the storm collar. See Figure 7.15.

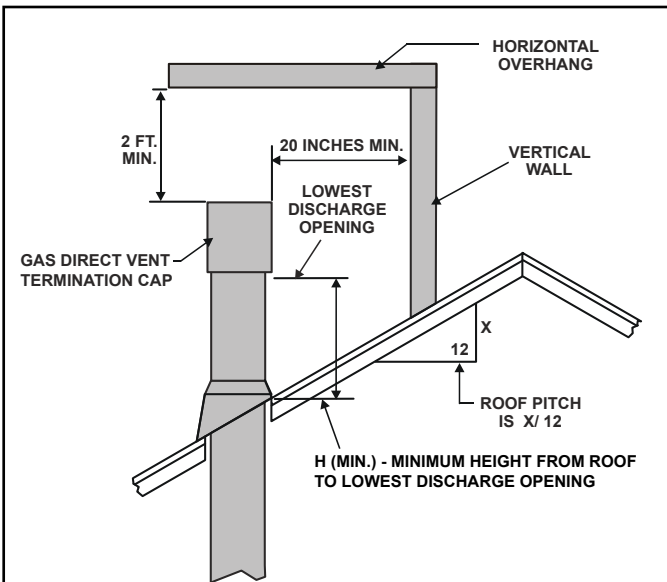

Roof Pitch	H (Min.) Ft.
Flat to 6/12.....	1.0*
Over 6/12 to 7/12.....	1.25*
Over 7/12 to 8/12.....	1.5*
Over 8/12 to 9/12.....	2.0*
Over 9/12 to 10/12.....	2.5*
Over 10/12 to 11/12.....	3.25
Over 11/12 to 12/12.....	4.0
Over 12/12 to 14/12.....	5.0
Over 14/12 to 16/12.....	6.0
Over 16/12 to 18/12.....	7.0
Over 18/12 to 20/12.....	7.5
Over 20/12 to 21/12.....	8.0

\* H minimum may vary depending on regional snowfall. Refer to local codes.

Figure 7.12 Minimum Height From Roof to Lowest Discharge Opening

## Install Vertical Termination Cap

- Attach the vertical termination cap by sliding the inner collar of the cap into the inner flue of the pipe section while placing the outer collar of the cap over the outer flue of the pipe section.
- Secure the cap by driving three self-tapping screws (supplied) through the pilot holes in the outer collar of the cap into the outer flue of the pipe (see Figure 7.15).

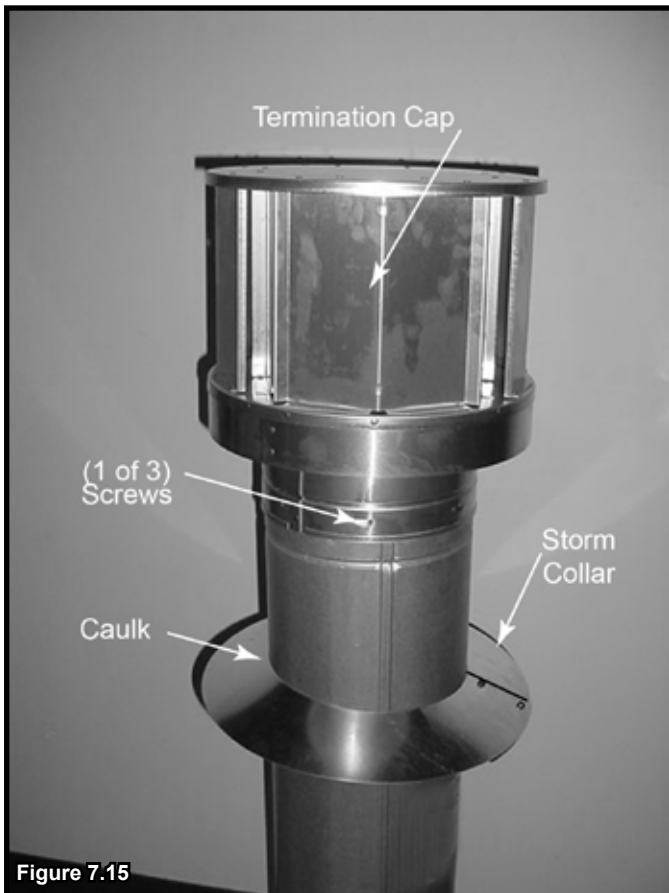

Figure 7.15

## G. Horizontal Termination Requirements

### Heat Shield Requirements for Horizontal Termination

**WARNING! Risk of Fire!** To prevent overheating and fire, heat shields must extend through the entire wall thickness.

- **DO NOT** remove the heat shields attached to the wall shield firestop and the horizontal termination cap (shown in Figure 7.16).
- Heat shields must overlap 1-1/2 in. (38 mm) minimum.

There are two sections of the heat shield. One section is factory-attached to the wall shield firestop. The other section is factory-attached to the cap. See Figure 7.16.

If the wall thickness does not allow the required 1-1/2 in. (38 mm) heat shield overlap when installed, an extended heat shield must be used.

- If the wall thickness is less than 4 in./102 mm (DVP) or 4-3/8 in./ 111 mm (SLP), the heat shields on the cap and wall shield firestop must be trimmed. A minimum 1-1/2 in. (38 mm) overlap **MUST** be maintained.
- Use an extended heat shield if the finished wall thickness is greater than 7-1/4 in. (184 mm).
- The extended heat shield may need to be cut to length maintaining sufficient length for a 1-1/2 in. (38 mm) overlap between heat shields.
- Attach the extended heat shield to either of the existing heat shields using the screws supplied with the extended heat shield. Refer to vent components diagrams in the back of this manual.
- Rest the small leg on the extended heat shield on top of the pipe section to properly space it from the pipe section.

**Important Notice:** Heat shields may not be field constructed.

## Install Horizontal Termination Cap (DVP and SLP Pipe)

**WARNING! Risk of Fire!** The telescoping flue section of the termination cap **MUST** be used when connecting vent.

- 1-1/2 (38 mm) minimum overlap of flue telescoping section is required.

Failure to maintain overlap could cause overheating and fire.

- Vent termination must not be recessed in the wall. Siding may be brought to the edge of the cap base.
- Flash and seal as appropriate for siding material at outside edges of cap.
- When installing a horizontal termination cap, follow the cap location guidelines as prescribed by current **ANSI Z223.1** and **CAN/CGA-B149** installation codes and refer to Section 4 of this manual.

**CAUTION! Risk of Burns!** Local codes may require installation of a cap shield to prevent anything or anyone from touching the hot cap.

**NOTICE:** For certain exposures which require superior resistance to wind-driven rain penetration, a flashing kit and HRC caps are available. When penetrating a brick wall, a brick extension kit is available for framing the brick.

**Note:** When using termination caps with factory-supplied heat shield attached, no additional wall shield firestop is required on the exterior side of a combustible wall.

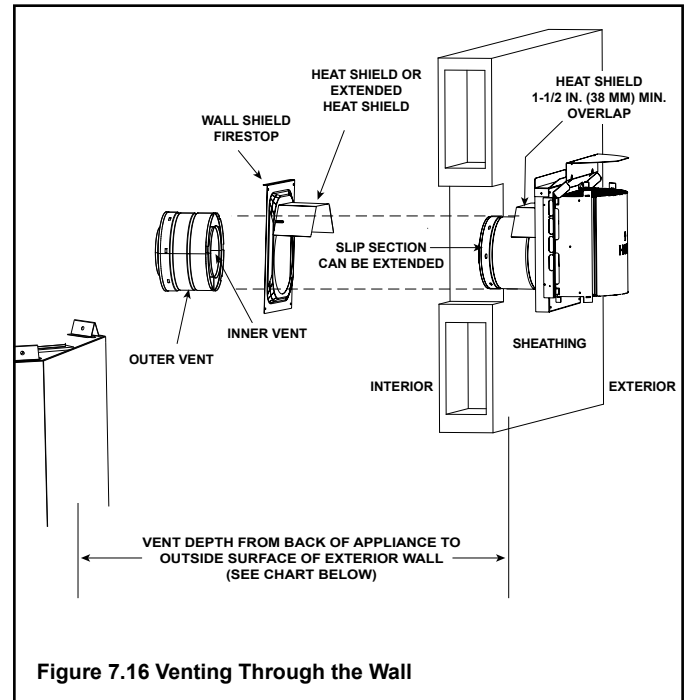

Figure 7.16 Venting Through the Wall

### Cap Specification Chart (depth without using additional pipe sections)

6000 Series 8000 Series	DVP-TRAPK1 Top Vent <u>Depth</u> 2-3/4 in. to 4-5/8 in.	DVP-TRAPK2 Top Vent <u>Depth</u> 5-1/8 in. to 9-1/8 in.
	DVP-HPC1 Top Vent <u>Depth</u> 2-3/4 in. to 4-7/8 in.	DVP-HPC2 Top Vent <u>Depth</u> 4-7/8 in. to 9 in.

DVP-TRAP1 can adjust 1-1/2 in. (3-1/8 to 4-5/8 in.)

DVP-TRAP2 can adjust 4 in. (5-3/8 to 9-3/8)

DVP-HPC1 can adjust 2-1/8 in. (4-1/4 to 6-3/8)

DVP-HPC2 can adjust 4-1/8 in. (6-3/8 to 10-1/2)



# 8 Electrical Information

## A. General Information

**WARNING! Risk of Shock or Explosion! DO NOT wire 110-120 VAC to the valve or to the appliance wall switch. Incorrect wiring will damage controls.**

**NOTICE:** This appliance must be electrically wired and grounded in accordance with local codes or, in the absence of local codes, with **National Electric Code ANSI/NFPA 70-latest edition or the Canadian Electric Code CSA C22.1.**

- Wire the appliance junction box to unswitched 110-120 VAC. This is required for use of optional accessories (standing pilot ignition) or proper operation of the appliance (IntelliFire® ignition).
- A 110-120 VAC circuit for this product must be protected with ground-fault circuit-interrupter protection, in compliance with the applicable electrical codes, when it is installed in locations such as in bathrooms or near sinks.
- Low voltage and 110-120 VAC voltage cannot be shared within the same wall box.
- In some instances, the spark ignition of the fireplace may cause intermittent, non-damaging, interference during the lighting sequence with a TV plugged into the same circuit. It is recommended that the fireplace and TV use different circuits to mitigate the interference potential. If interference is occurring on the same circuit, the use of surge protectors may help alleviate the interference.

## Junction Box Installation

If the box is being wired from the **INSIDE** of the appliance:

- Remove the screw attaching the junction box/receptacle to the outer shell, rotate the junction box inward to disengage it from the outer shell. See Figure 8.1.
- Pull the electrical wires from outside the appliance through the opening into the valve compartment and secure wires with a Romex connector. See Figure 8.1.
- Make all necessary wire connections to the junction box/receptacle and reattach the junction box/receptacle to the outer shell.

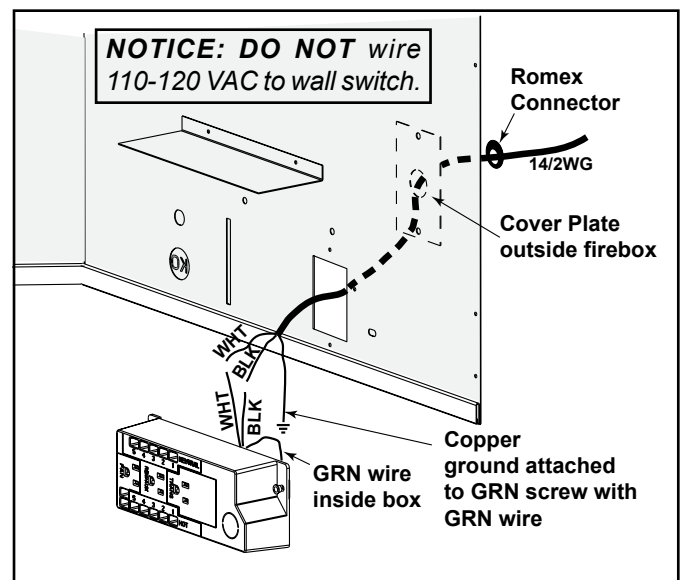

Figure 8.1 Junction Box Detail

## Accessories Requirements

- This appliance may be used with a wall switch, wall mounted thermostat and/or a remote control.

Wiring for optional Hearth & Home Technologies approved accessories should be done now to avoid reconstruction. Follow instructions that come with those accessories.

## Electrical Service and Repair

**WARNING! Risk of Shock! Label all wires prior to disconnection when servicing controls. Wiring errors could cause improper and dangerous operation. Verify proper operation after servicing.**

**WARNING! Risk of Shock! Replace damaged wire with type 105° C rated wire. Wire must have high temperature insulation.**

## B. Wiring Requirements

### IntelliFire Touch® Ignition System Wiring

- Wire the appliance junction box to 110-120 VAC for proper operation of the appliance.

**WARNING! Risk of Shock or Explosion! DO NOT wire IPI controlled appliance junction box to a switched circuit. Incorrect wiring will override IPI safety lockout.**

- Refer to Figure 8.2 IntelliFire Touch (IPI) Wiring Diagram.
- This appliance is equipped with an IntelliFire® control valve which operates on a 6 volt system.

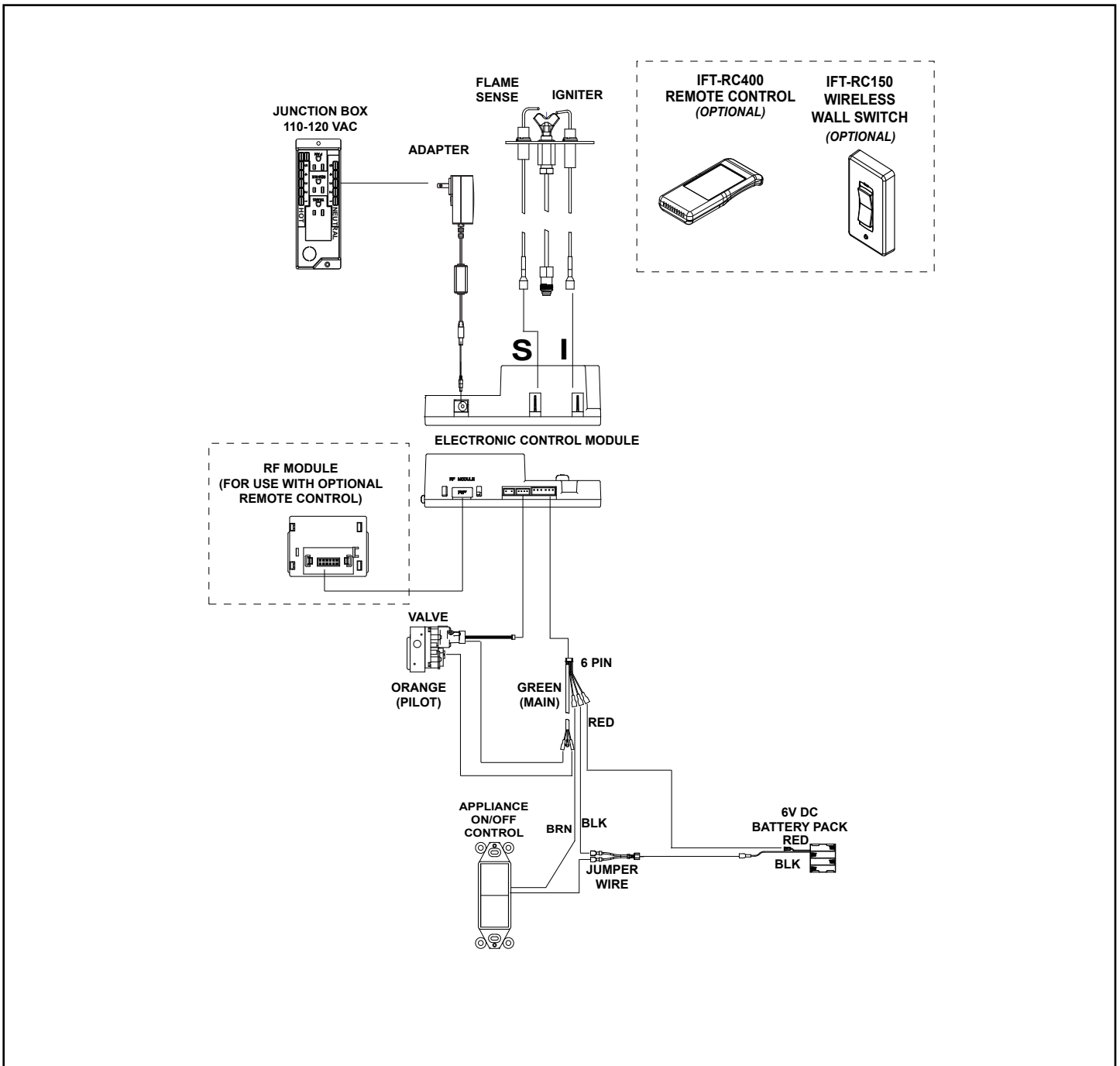
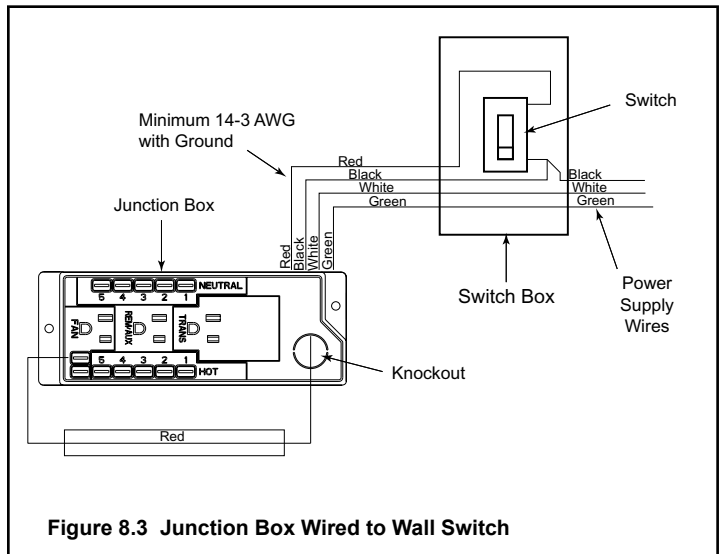

Figure 8.2 IntelliFire Touch Wiring Diagram

## Wall Switch Installation for Fan (Optional)

If the box is being wired to a wall mounted switch for use with a fan. See Figure 8.3:

- The power supply for the appliance must be brought into a switch box.
- The power can then be supplied from the switch box to the appliance using a minimum of 14-3 with ground wire.
- At the switch box connect the black (hot) and red (switch leg) wire to the wall switch as shown.
- At the appliance connect the black (hot), white (neutral) and green (ground) wires to the junction box as shown.
- Add a 1/4 in. insulated female connector to the red (switch leg) wire, route it through the knockout in the face of the junction box, and connect to the top fan switch connector (1/4 in. male) as shown.



# 9 Gas Information

## A. Fuel Conversion

**WARNING! Risk of Fire or Explosion!** Appliance must be set up for compatible gas type!

- **This appliance is designed to operate using only natural gas. Gas conversion is NOT allowed for this appliance.**

## B. Gas Pressure

- Optimum appliance performance requires proper input pressures.
- Gas line sizing requirements will be determined in ANSI Z223.1 National Fuel Gas Code in the USA and CAN/CGA B149 in Canada.
- Pressure requirements are:

Gas Pressure	Natural Gas
Minimum inlet pressure	5.0 in. w.c.
Maximum inlet pressure	10.0 in. w.c.
Manifold pressure	3.5 in. w.c.

**WARNING! Risk of Fire or Explosion!** High pressure will damage valve. Low pressure could cause explosion.

- Verify inlet pressures. Verify minimum pressures when other household gas appliances are operating.
- Install regulator upstream of valve if line pressure is greater than 1/2 psig.

<b>⚠ WARNING</b>	
	<p>Fire Risk. Explosion Hazard. High pressure will damage valve.</p> <ul style="list-style-type: none"><li>• Disconnect gas supply piping BEFORE pressure testing gas line at test pressures above 1/2 psig.</li><li>• Close the manual shutoff valve BEFORE pressure testing gas line at test pressures equal to or less than 1/2 psig.</li></ul>

**Note:** Have the gas supply line installed in accordance with local codes, if any. If not, follow ANSI Z223.1. Installation should be done by a qualified installer approved and/or licensed as required by the locality. (In the Commonwealth of Massachusetts installation must be performed by a licensed plumber or gas fitter).

**Note:** A listed (and Commonwealth of Massachusetts approved) 1/2 in. (13 mm) T-handle manual shut-off valve and flexible gas connector are connected to the 1/2 in. (13 mm) control valve inlet.

- **If substituting for these components, please consult local codes for compliance.**

## C. Gas Connection

- Refer to Section 3 for location of gas line access in appliance.
- Gas line may be run through knockout(s) provided.
- The gap between supply piping and gas access hole may be caulked with caulk with a minimum of 300 °F continuous exposure rating or stuffed with non-combustible, unfaced insulation to prevent cold air infiltration.
- Ensure that gas line does not come in contact with outer wrap of the appliance. Follow local codes.
- Pipe incoming gas line into valve compartment.
- Connect incoming gas line to the 1/2 in. (13 mm) connection on manual shutoff valve.

**WARNING! Risk of Fire or Explosion!** Support control when attaching pipe to prevent bending gas line.

- A small amount of air will be in the gas supply lines.
- **WARNING! Risk of Fire or Explosion!** Gas build-up during line purge could ignite.
- Purge should be performed by qualified service technician.
- Ensure adequate ventilation.
- Ensure there are no ignition sources such as sparks or open flames.

Light the appliance. It will take a short time for air to purge from lines. When purging is complete the appliance will light and operate normally.

**WARNING! Risk of Fire, Explosion or Asphyxiation!** Check all fittings and connections with a non-corrosive commercially available leak-check solution. **DO NOT** use open flame. Fittings and connections could have loosened during shipping and handling.

**WARNING! Risk of Fire! DO NOT** change valve settings. This valve has been preset at the factory.

## D. High Altitude Installations

**NOTICE:** If the heating value of the gas has been reduced, these rules do not apply. Check with your local gas utility or authorities having jurisdiction.

When installing above 2000 feet elevation:

- In the USA: Reduce input rate 4% for each 1000 feet above 2000 feet.
- In CANADA: Input ratings are certified without a reduction of input rate for elevations up to 4500 feet (1370 m) above sea level. Please consult provincial and/or local authorities having jurisdiction for installations at elevations above 4500 feet (1370 m).

Check with your local gas utility to determine proper orifice size.

## E. Air Shutter Setting

Air shutter settings should be adjusted by a qualified service technician at the time of installation. The air shutter is set at the factory for minimum vertical vent run. Adjust air shutter for longer vertical runs. See Figure 9.1.

- Loosen the wing nut.
- Move the air handle to the left to open the air shutter.
- Move the air handle to the right to close the air shutter.
- Tighten the wing nut.

**NOTICE:** If sooting occurs, provide more air by opening the air shutter.

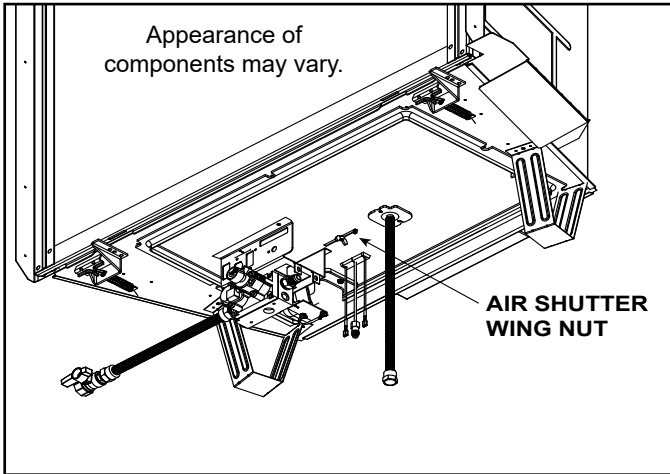

Figure 9.1 Air Shutter

### Air Shutter Settings

	NG
6000CMOD-IFT	Fully Closed
8000CMOD-IFT	Fully Open

# 10 Finishing

## A. Facing Material

- Metal front faces may be covered with non-combustible materials only.
- Facing and/or finishing materials must not interfere with air flow through or removal of decorative fronts or access for service.
- Facing and/or finishing materials must never overhang into the glass opening.
- Observe all clearances when applying combustible materials.
- Seal joints between the finished wall and appliance top and sides using a 300 °F minimum sealant. Refer to Figure 10.1.

**WARNING! Risk of Fire! DO NOT** apply combustible materials beyond the minimum clearances. Comply with all minimum clearances to combustibles as specified in this manual. Overlapping materials could ignite and will interfere with air flow through decorative fronts.

**NOTICE:** Surface temperatures around the appliance will become warm while the appliance is in operation. Ensure finishing materials used for all surfaces (floor, walls, mantels, etc.) will withstand temperatures up to 190°F.

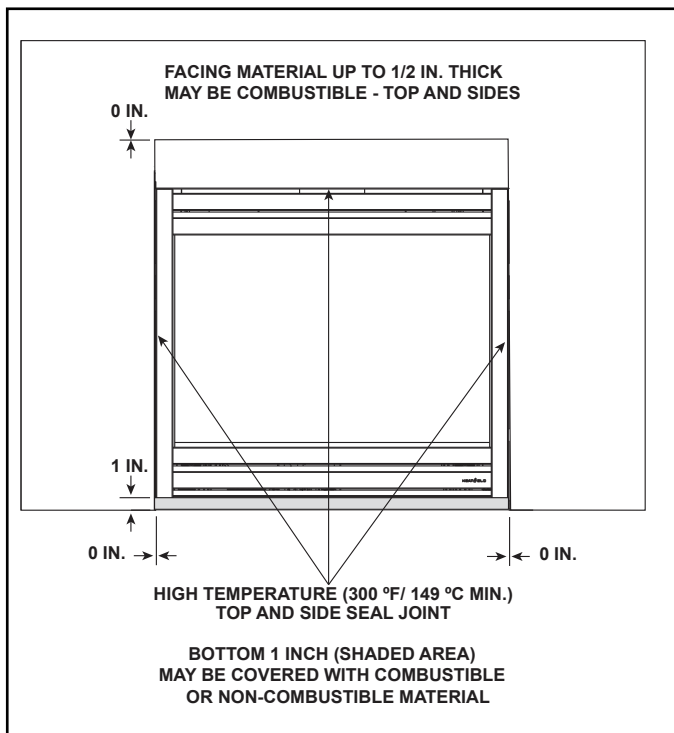

Figure 10.1 Facing Materials

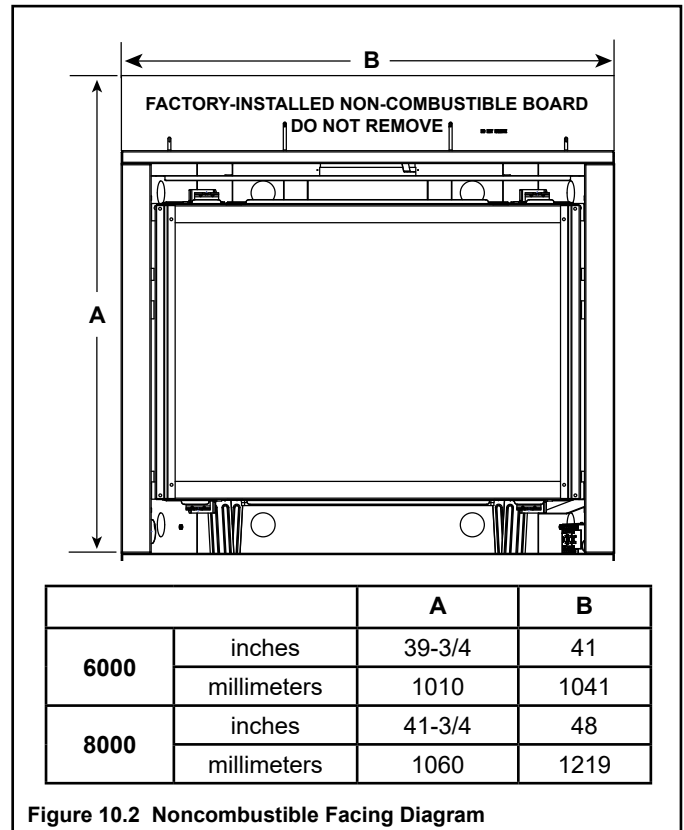

Figure 10.2 Noncombustible Facing Diagram

## Finish and Sealing Joints

All joints between the finished wall sheathing and the appliance must be sealed with non-combustible materials. Sealants, such as caulk or mastic used to seal the gap between the wall and the fireplace, should be rated at a minimum continuous exposure to 300 °F.

## Finishing Around Opening with Gypsum Wallboard

Gypsum wallboard (drywall) joints adjacent to the fireplace opening, including the non-combustible board on the appliance, require special attention to minimize cracking. When installing gypsum wallboard around the fireplace, install the hole for the fireplace opening in a single wallboard sheet, if possible. This will minimize the joints adjacent to the fireplace opening.

Tape wall board joints around the fireplace opening with fiberglass-mesh tape. It will provide a more crack-resistant joint than paper tape. Fill, smooth and finish wall joints with chemically setting-type joint compound. It will provide a more crack-resistant joint than air-drying light-weight compound.

## Painting

If desired finishing includes a painted wall, 100% acrylic latex with compatible primer is recommended around this appliance. Oil-based or standard acrylic paints may discolor due to heat exposure.

## B. Mantel and Wall Projections

**WARNING! Risk of Fire!** Comply with all minimum clearances as specified. Framing closer than the minimums listed must be constructed entirely of noncombustible materials (i.e., steel studs, concrete board, etc.)

### Mantels - Combustible or Painted Surfaces

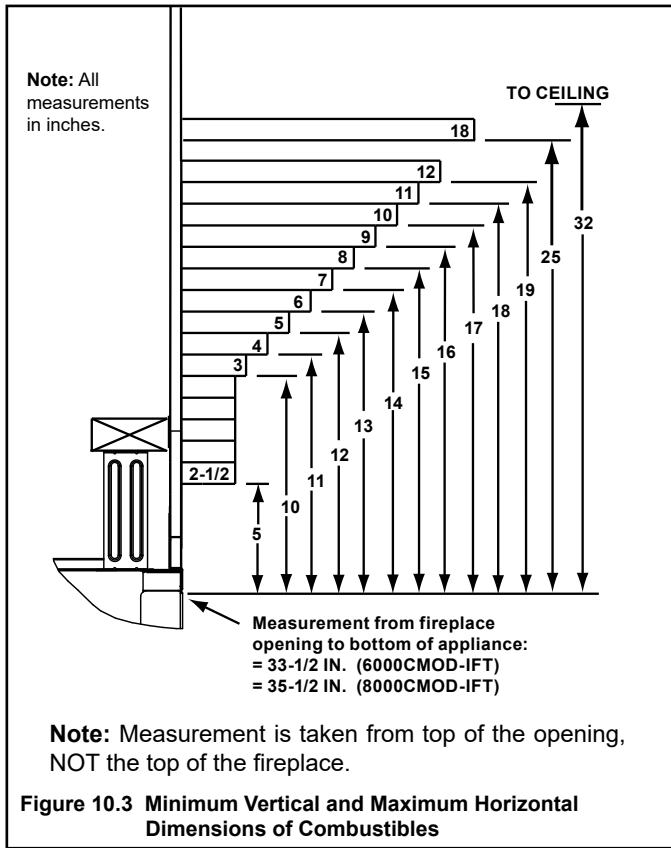

### Mantel Legs or Wall Projections

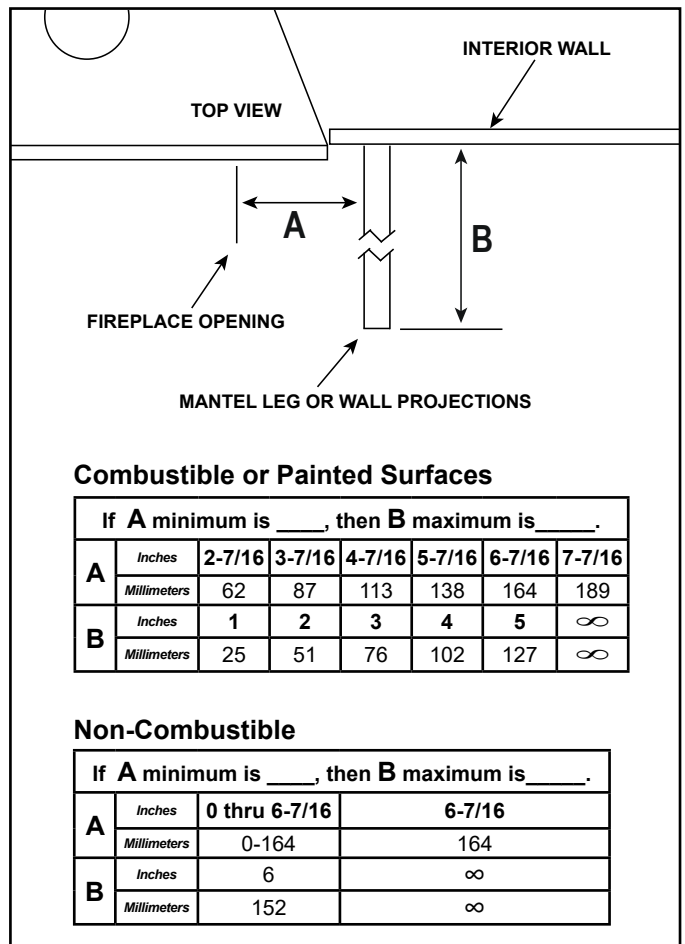

### Mantels - Non-Combustible

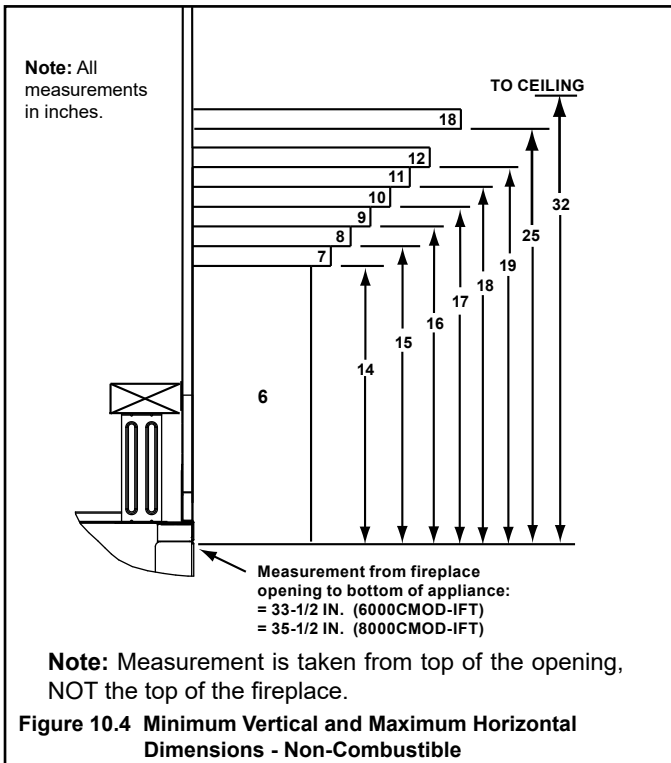

### C. Decorative Fronts

Only decorative fronts certified for use with this appliance model may be used. Contact your dealer for a list of decorative fronts that may be used. Once you have determined what kind of decorative front and finishing material is going to be used on the fireplace, you may use the table below which shows the decorative front models and the finishing material thickness allowed.

**Note:** Finishing strips may be used to aid in positioning of non-combustible facing materials for some of the facing and decorative front combinations specified in the table above. They must be removed following finishing work. See Figure 10.9.

DECORATIVE FRONT	FIT	FINISH MATERIAL THICKNESS	SEE FIGURE
Folio	Inside	0-6 inches max.	10.8
Arcadia	Overlap	1 inch or less	10.6
	Inside	1-6 inches max.	10.7
Halston	Overlap	1 inch or less	10.6
	Inside	1-6 inches max.	10.7
Chateau	Overlap	1 inch or less	10.6
	Inside	1-6 inches max.	10.7
Chateau Forge	Overlap	1 inch or less	10.6
	Inside	1-6 inches max.	10.7
Galleria	Overlap	1 inch or less	10.6
	Inside	1-6 inches max.	10.7
CF	Inside	0-6 inches max.	10.8
Iron Age	Overlap	1 inch or less	10.6
	Inside	1-6 inches max.	10.7

### Finishing Material: 1 Inch Thick or Less

Remove Finishing Strips. See Figure 10.9.

**NOTICE:** Remove finishing strips before firing appliance.

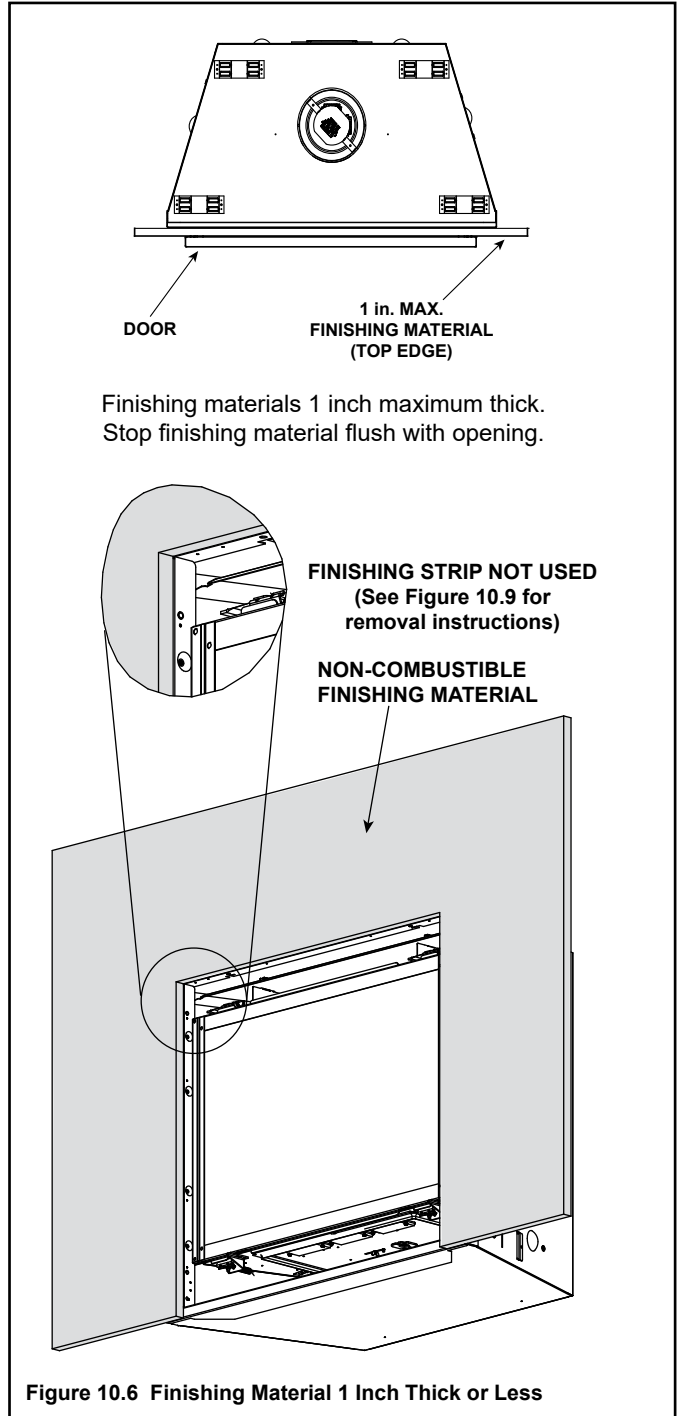



## Finishing Material Thickness: 1-6 Inches Maximum

**NOTICE:** Remove finishing strips before firing appliance.

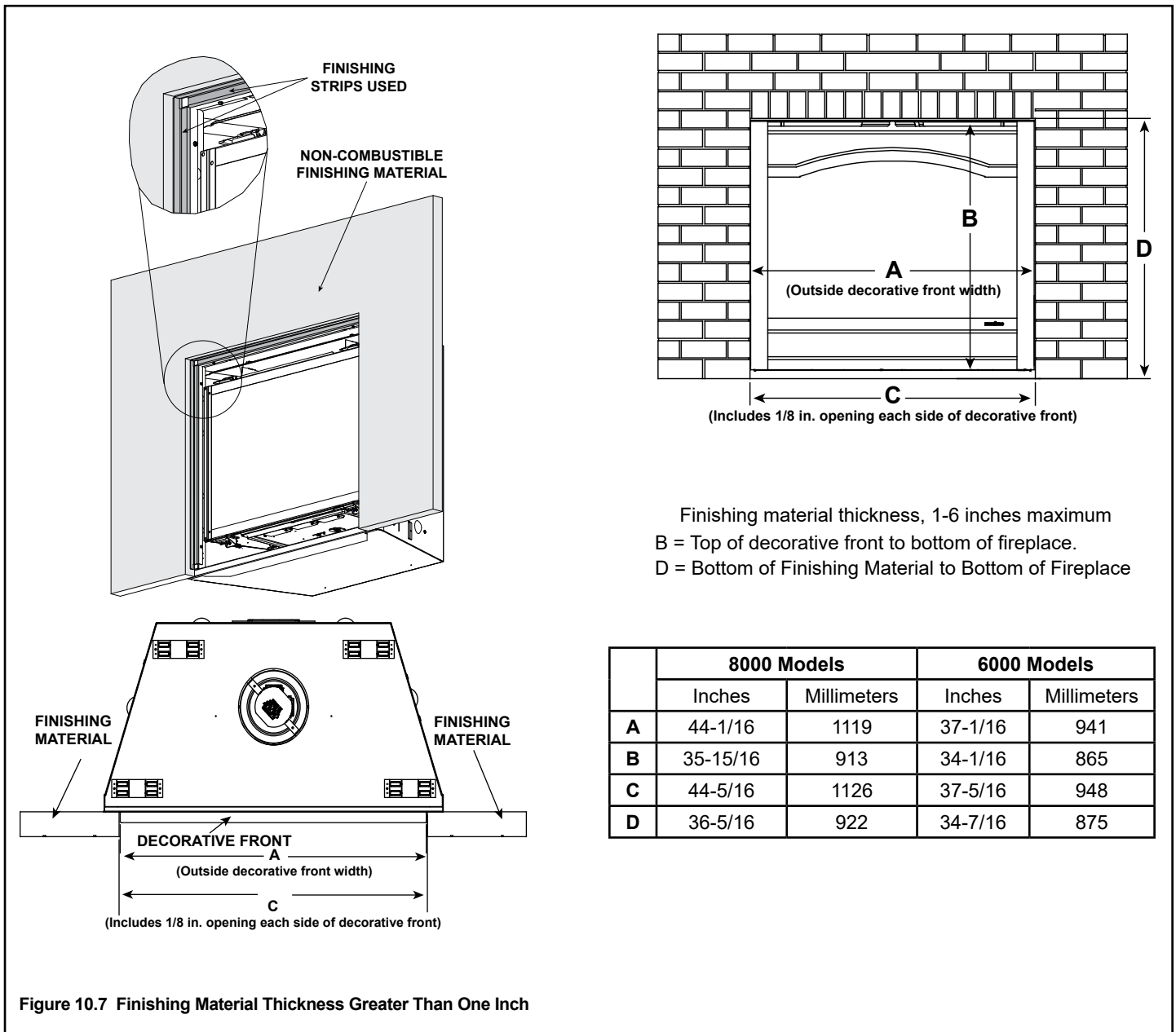
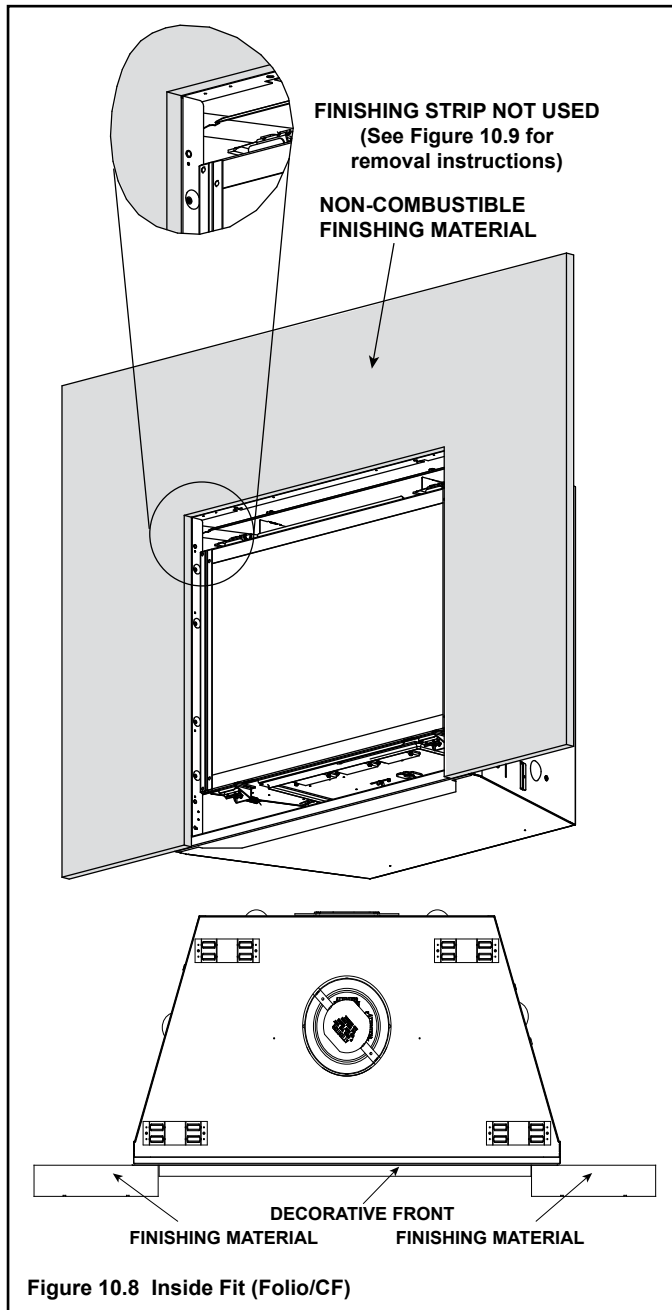

Figure 10.7 Finishing Material Thickness Greater Than One Inch

**Finishing Material Thickness:  
0-6 Inches Maximum**

**NOTICE:** Remove finishing strips before firing appliance.



**Removal of Finishing Strips**

**NOTICE:** Remove finishing strips before firing appliance.  
Remove glass frame assembly to access finishing strip screws.

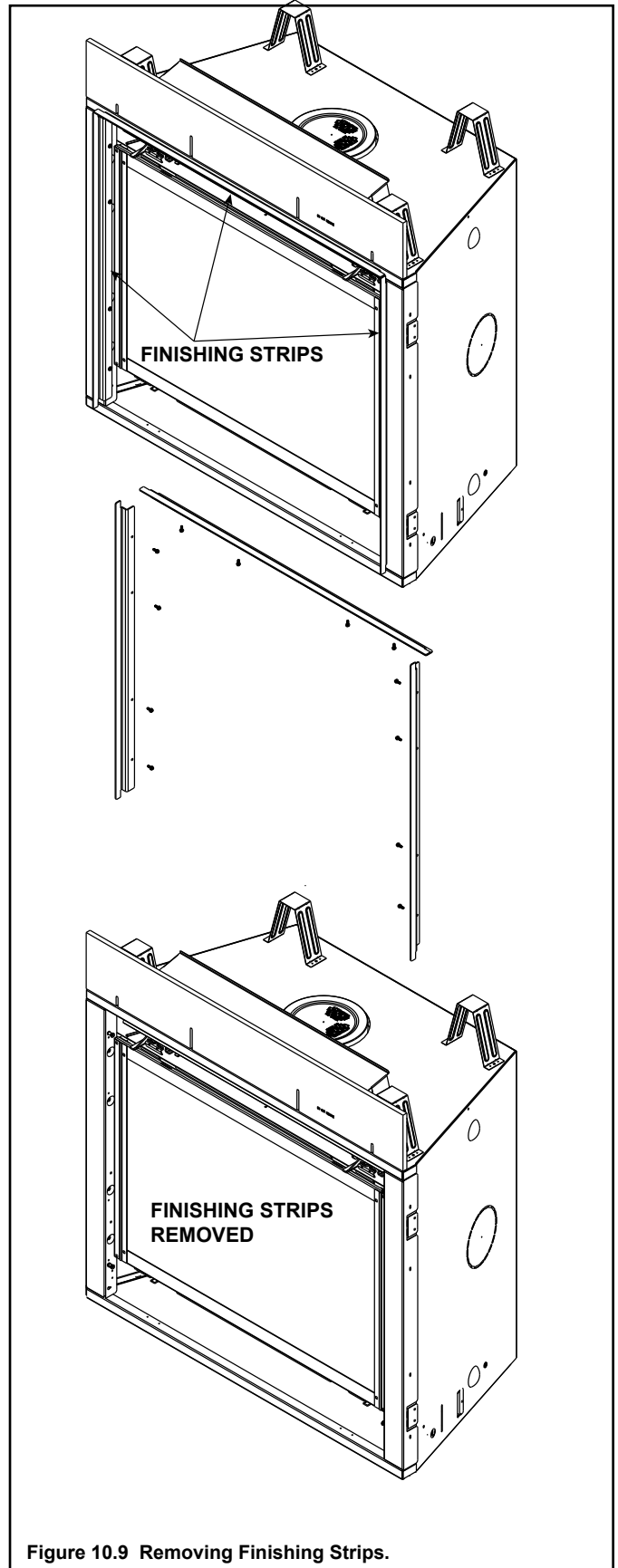

# 11 Appliance Setup

## A. Remove Fixed Glass Assembly

**WARNING! Risk of Asphyxiation!** Handle fixed glass assembly with care. Inspect the gasket to ensure it is undamaged and inspect the glass for cracks, chips or scratches.

- **DO NOT** strike, slam or scratch glass.
- **DO NOT** operate fireplace with glass removed, cracked, broken or scratched.
- Replace as a complete assembly.

### Removing Fixed Glass Assembly

- Pull the four glass assembly latches out of the groove on the glass frame. Remove glass assembly from the appliance.

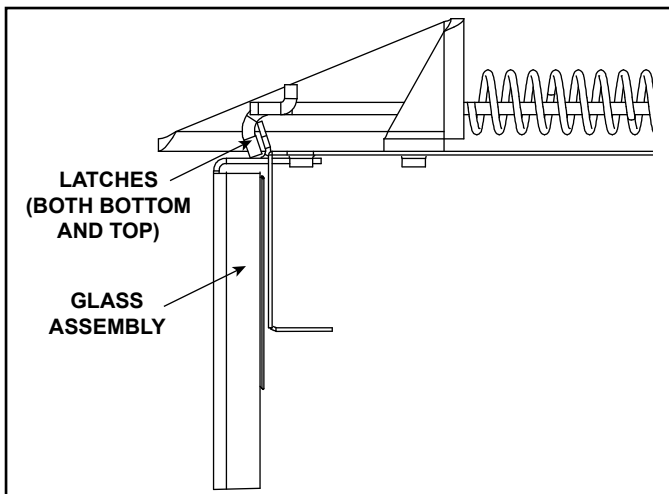

Figure 11.1 Fixed Glass Assembly

## B. Remove the Shipping Materials

Remove shipping materials from inside or underneath the firebox.

- The splatter guard is a piece of corrugated material used to protect the appliance during the installation process before finishing work on the whole hearth is complete. Splatter guards may be factory installed or accompany the decorative front of the appliance, depending on the fireplace model. Splatter guards must be removed before appliance is fired.

**WARNING! Risk of Fire!** Close the ball valve before installing the splatter guard to prevent accidental lighting. Remove the splatter guard before lighting the appliance.

## C. Clean the Appliance

Clean/vacuum any sawdust that may have accumulated inside the firebox or underneath in the control cavity.

## D. Glass Panel Installation

**CAUTION! Risk of Cuts, Abrasions or Flying Debris.** Wear protective gloves and safety glasses during installation.

**CAUTION! Glass is fragile.** Handle with care.

**Note:** Place the fluted side of the glass panels toward the burner.

1. Install the rear glass panel as shown in Figure 11.2. The panel retainers and screws are included in the appliance manual bag. Attach as shown in Figure 11.3.

**Note:** Center the glass panel retainer and screw to the firebox using 1 self tapping screw.

2. Slide the side glass panels in positions as shown in Figure 11.4. Center the glass retainers and screw to the firebox using 1 self tapping screw per retainer, similar to installation shown in Figure 11.3.
3. Figure 11.5 shows the glass panels installed properly.

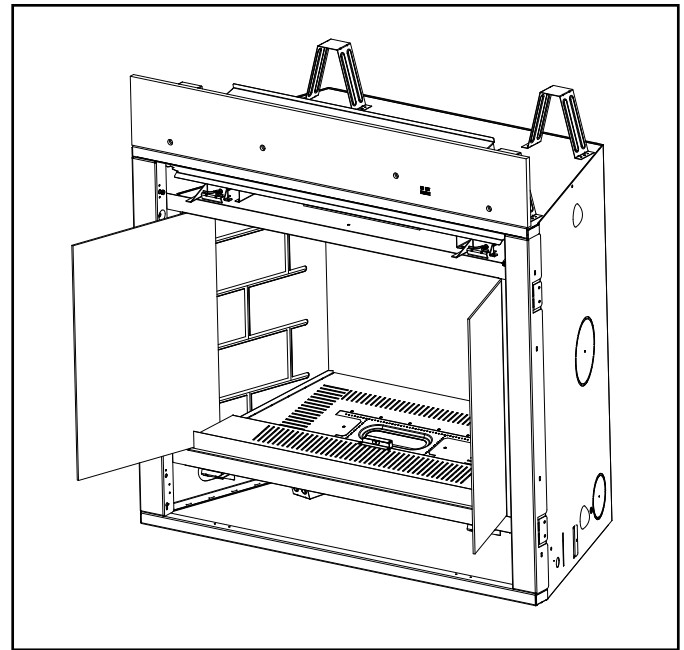

Figure 11.4 Install Side Glass Panels

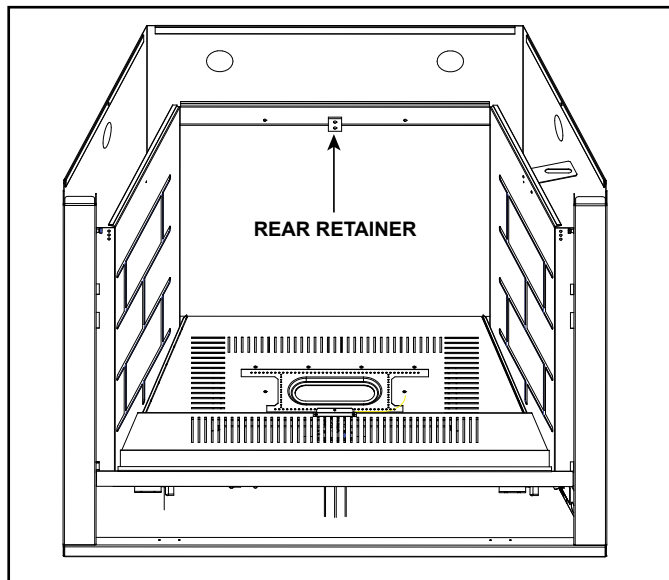

Figure 11.2 Install Rear Retainer

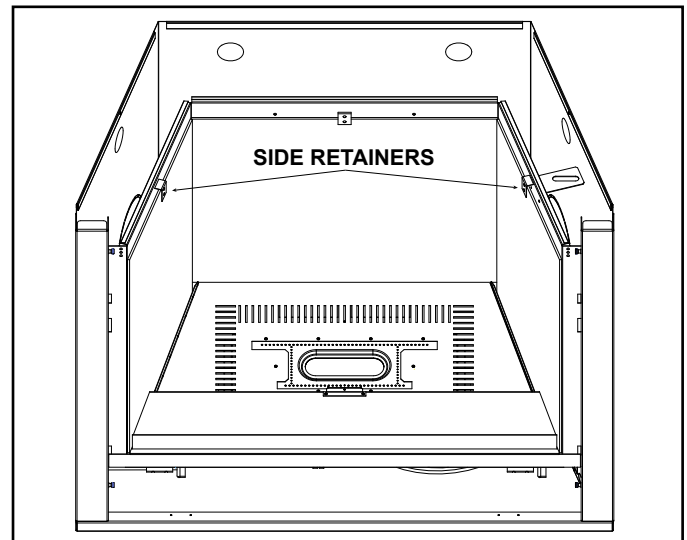

Figure 11.5 Install Side Retainers

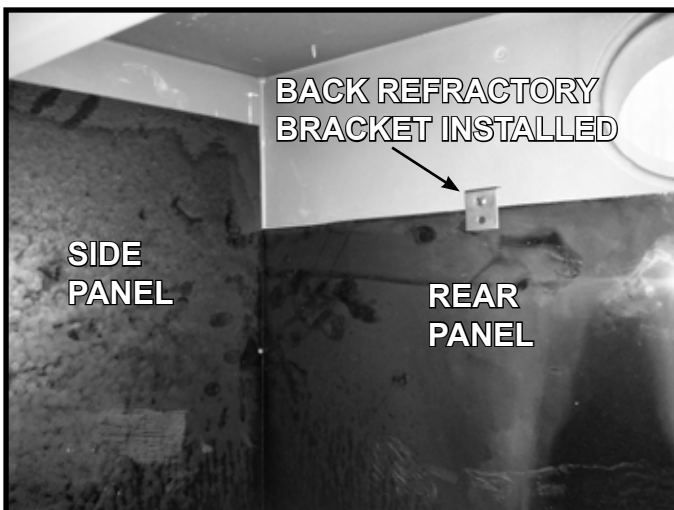

Figure 11.3 Side Panel Flush with Rear Panel

## E. Media Placement

**WARNING! Risk of Explosion!** Follow media placement instructions. Improperly placed media interfere with proper burner operation. Fireplace will not function properly. Delayed ignition may occur.

**WARNING! Choking Hazard!** Keep media out of reach of children.

- DO NOT place media in pilot opening.
- DO NOT place media in a position that it may fall into the pilot opening.
- DO NOT use any media other than the media supplied with this fireplace or listed in Service Parts Section in this manual.
- DO NOT use more than 14 lb. of media per 8000CMOD-IFT or 12 lb. per 6000CMOD-IFT fireplace.

**Note: One bag of glass contains 5 lbs.**

Extra media may be saved for future use.

1. Place media evenly on the base pan. Figure 11.7 shows properly placed media.
2. The media can only be placed in the shaded areas as shown in Figure 11.8 and Figure 11.9.
3. Do not apply media over the pilot opening. See Figure 11.8 and Figure 11.9.
4. The rock fixture assembly is factory installed in the appliance. See Figure 11.6.
5. After the media is properly installed, carefully remove the rock fixture assembly. Do not allow any media to fall into the opening. See Figure 11.7. Store the rock fixture assembly under the appliance for future use.



Figure 11.6 Rock Fixture Installed



Figure 11.7 Remove Rock Fixture Assembly (Optional Clear Glass Media Shown)

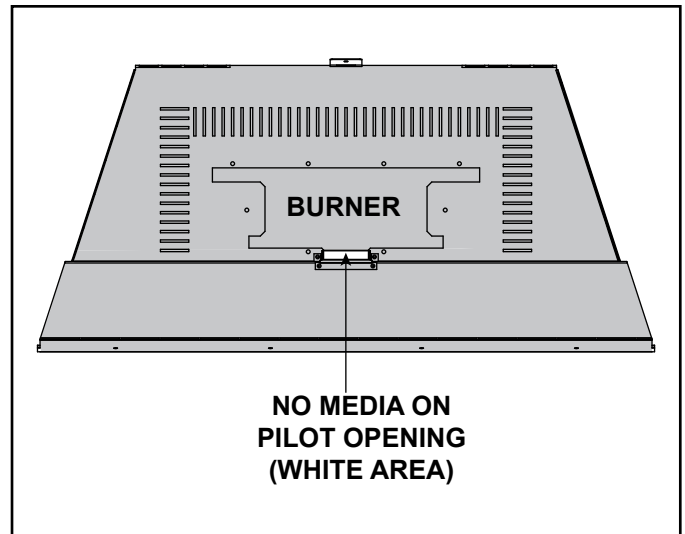

Figure 11.8 Placement of Media

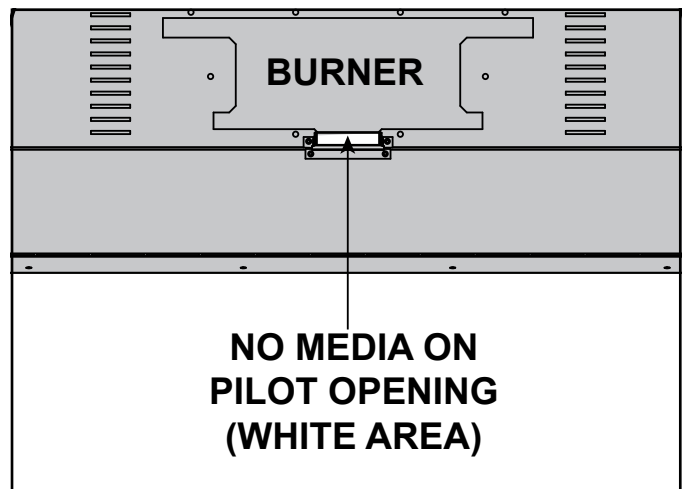

Figure 11.9 Placement of Media



Figure 11.10 Proper Placement of Media  
(Optional Clear Glass Media Shown)

## F. IntelliFire Touch® Control System Setup

- Detailed instructions for electrical wiring and connections are provided in Section 8.
- Determine if this appliance is equipped with a Module Reset Switch. See Section 8. Verify this switch is in the ON position.
- Verify that the 3-Position switch on the IFT-ECM is switched to the REMOTE position. Detailed Operating Instructions for the IFT-ECM are provided in Section 3.J of the Owner's Manual.

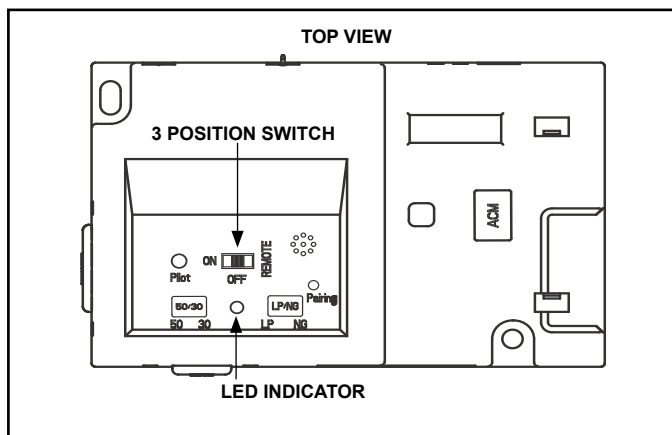

Figure 11.11 IFT-ECM

If this appliance is being upgraded to an optional IntelliFire Touch Remote Control, and/or optional power vent, fan, or light kit are added as new accessory upgrade(s) to fireplace:

1. The RC400 remote will need to be paired to the ECM.
2. Follow the installation instructions provided with the IntelliFire Touch remote and/or accessory kit(s).

## G. Fixed Glass Assembly

**WARNING! Risk of Asphyxiation!** Handle fixed glass assembly with care. Inspect the gasket to ensure it is undamaged and inspect the glass for cracks, chips or scratches.

- **DO NOT** strike, slam or scratch glass.
- **DO NOT** operate fireplace with glass removed, cracked, broken or scratched.
- Replace as a complete assembly.

### Replacing Fixed Glass Assembly

- Replace the glass assembly on the appliance. Pull out and latch the four glass assembly latches into the groove on the glass frame. See Figure 11.1.

## H. Install Decorative Front

**WARNING! Risk of Fire!** Install **ONLY** decorative fronts approved by Hearth & Home Technologies. Unapproved decorative fronts could cause fireplace to overheat.

**This fireplace has been supplied with an integral barrier to prevent direct contact with the fixed glass panel. DO NOT operate the fireplace with the barrier removed.**

Contact your dealer or Hearth & Home Technologies if the barrier is not present or help is needed to properly install one.

For more information refer to the instructions supplied with your decorative front.

# 12 Reference Materials

## A. Vent Components Diagrams

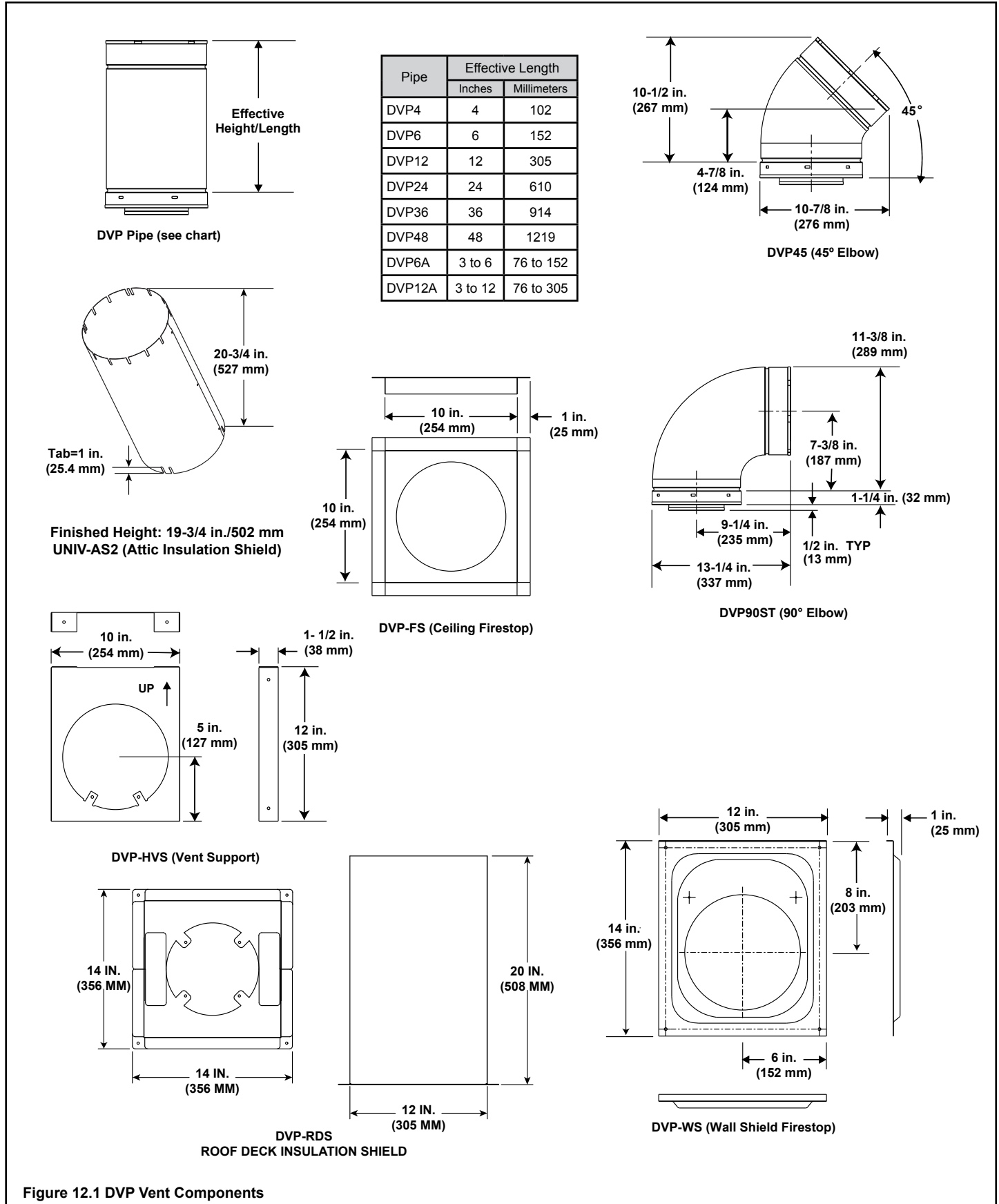
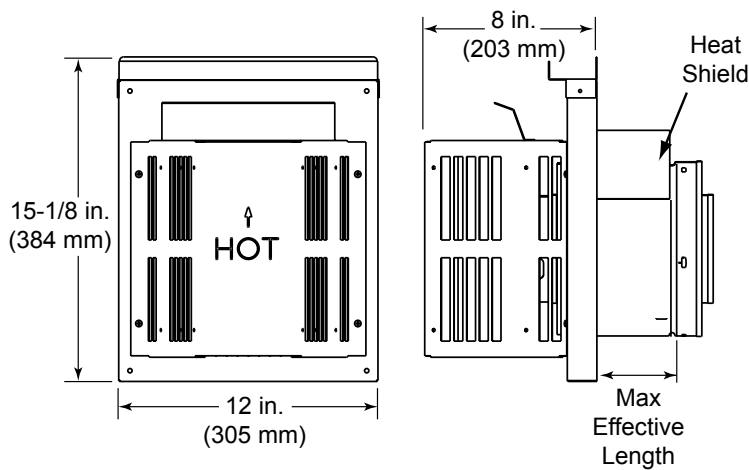

Figure 12.1 DVP Vent Components

## A. Vent Components Diagrams (continued)

Note: Heat shields MUST overlap by a minimum of 1-1/2 in. (38 mm). The heat shield is designed to be used on a wall 4 in. to 7-1/4 in. (102 mm to 184 mm) thick. If wall thickness is less than 4 in. (102 mm) the existing heat shields must be field trimmed. If wall thickness is greater than 7-1/4 in. (184 mm) a DVP-HSM-B will be required.



**DVP-TRAP**  
Horizontal Termination Cap

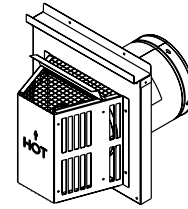

Term Cap	Minimum Effective Length	Maximum Effective Length
Trap1	3-1/8 in.	4-5/8 in.
	79 mm	117 mm
Trap2	5-3/8 in.	9-3/8 in.
	137 mm	238 mm

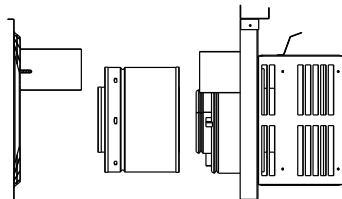

**DVP-TRAP1**

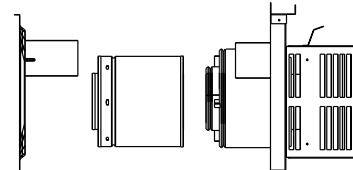

**DVP-TRAP2**

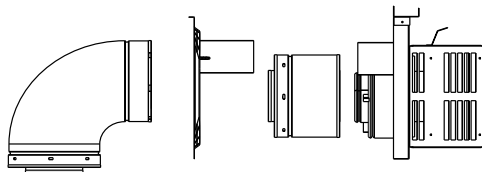

**DVP-TRAPK1**

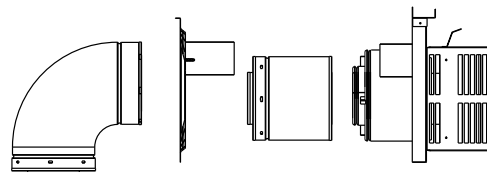

**DVP-TRAPK2**

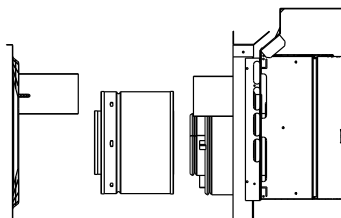

**DVP-HPC1**

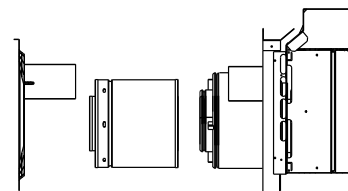

**DVP-HPC2**

Figure 12.2 DVP Vent Components



**A. Vent Components Diagrams (continued)**

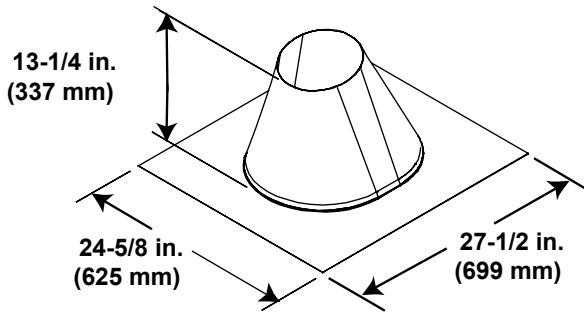

**RF6  
Roof Flashing**

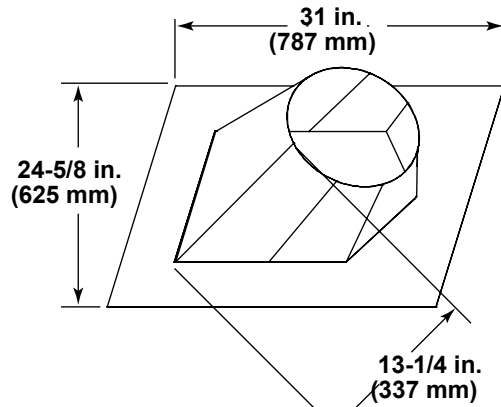

**RF12  
Roof Flashing**

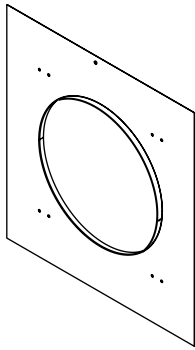

**DVP-TRAPFL  
Flashing**

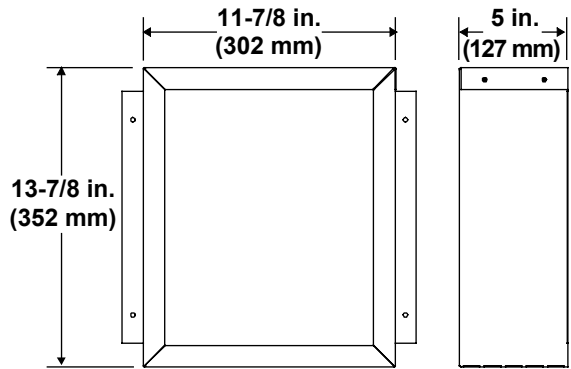

**DVP-BEK2  
DVP-HPC Cap Brick Extension**

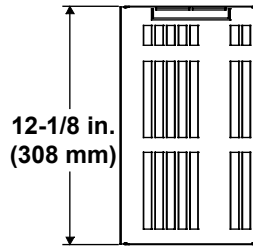
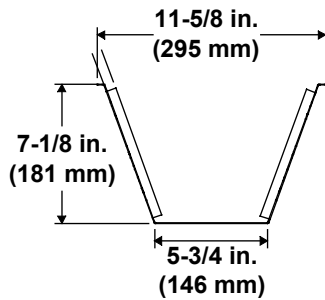

**COOL-ADDM  
Cap Shield**

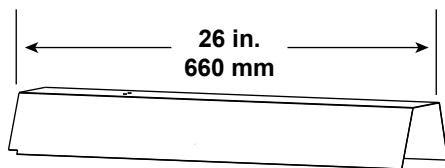
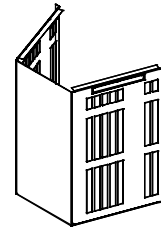

**DVP-HSM-B  
Extended Heat Shield**

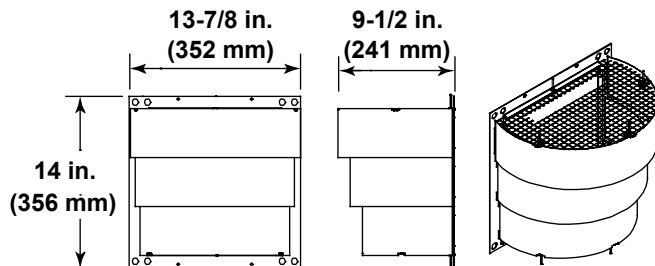

**DRC-RADIUS  
Cap Shield**

**Figure 12.3 DVP Vent Components**

## A. Vent Components Diagrams (continued)

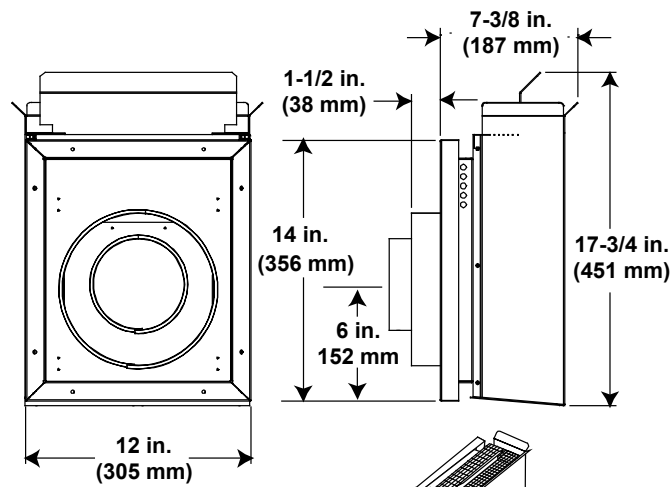

**DVP-TB1**  
Basement Vent Cap

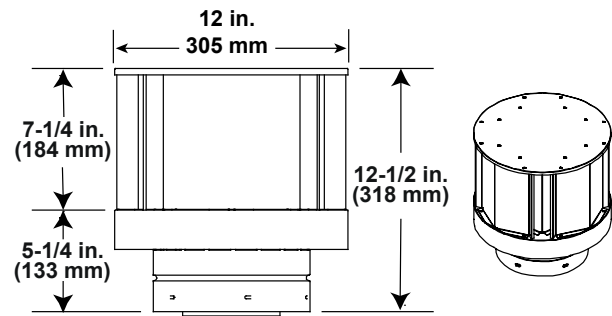

**DVP-TVHW**  
Vertical Termination Cap (Highwind)

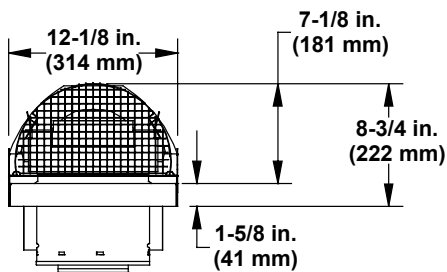
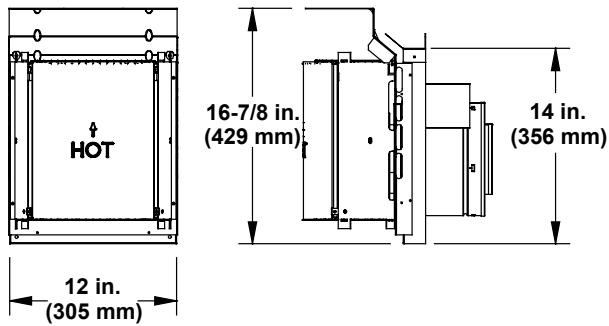

**DVP-HPC**  
High Performance Cap

Figure 12.4 DVP Vent Components

## A. Vent Components Diagrams (continued)

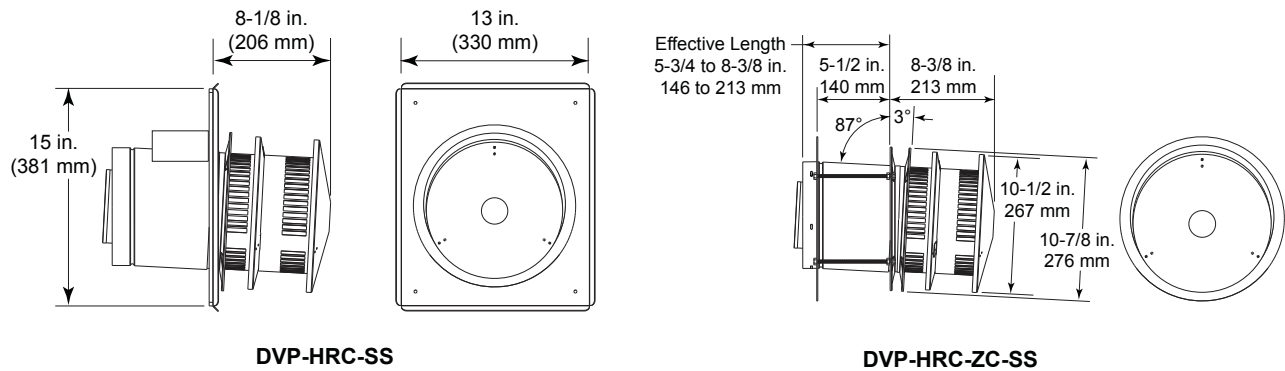

### **WARNING**



Fire Risk.

- When using DVP-HRC-SS and DVP-HRC-ZC-SS termination cap on top vented fireplaces, a 6 inch minimum vertical vent section is required before installing first elbow.

Only use listed decorative termination caps/shrouds with Hearth & Home Technologies approved venting systems.

This applies to both DVP and SLP venting systems.

### Decorative Terminations Caps/Shrouds

DTO134  
 DTO146  
 DTS134  
 DTS146  
 LDS33  
 LDS46  
 LDS-BV

Figure 12.5 DVP Vent Components

## A. Vent Components Diagrams (continued)

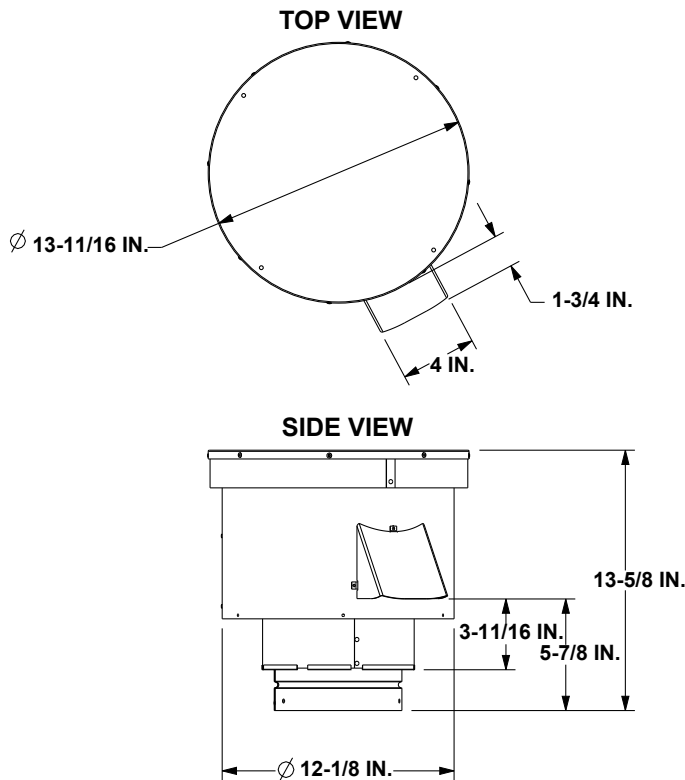

**PVV-SLP**  
Vertical Power Vent

Required Wire Harness and PVV-SLEEVE	
Lengths Available	Part Number
10 ft. PV Wire Harness	PVI-WH10
20 ft. PV Wire Harness	PVI-WH20
40 ft. PV Wire Harness	PVI-WH40
60 ft. PV Wire Harness	PVI-WH60
80 ft. PV Wire Harness	PVI-WH80
100 ft. PV Wire Harness	PVI-WH100
Description	Part Number
12 in. Wire Harness Sleeve	PVV-SLEEVE-12
48 in. Wire Harness Sleeve	PVV-SLEEVE-48

**Note:** A wire harness is required to power the PVV-SLP and connect it to the appliance. It is ordered separately from the PVV-SLP. Contact your dealer to order.

**Note:** The PVV-SLEEVE-12 and/or PVV-SLEEVE-48 is required to be installed with the PVV-SLP. It is ordered separately from the PVV-SLP. Contact your dealer to order.

**Note:** The PVV-SLP requires one of the following options to be installed on this appliance.

Option A: IFT-RC400 and/or IFT-WFM, IFT-ACM and IntelliFire App that can be downloaded from the app store.

**OR**

Option B: IFT-RC150, IFT-ACM, IFT-WFM and an IntelliFire App that can be downloaded from the app store. These accessories are purchased separately from the PVI-SLP-B. Contact your dealer to order.

**Note:** The PVV-SLP requires one of the following options to be installed on this appliance.

Option A: IFT-RC400 **OR**

Option B: IFT-RC150 and IFT-ACM.

These accessories are purchased separately from the PVV-SLP. Contact your dealer to order.

**Figure 12.6 PVV-SLP Vent Components**

## A. Vent Components Diagrams (continued)

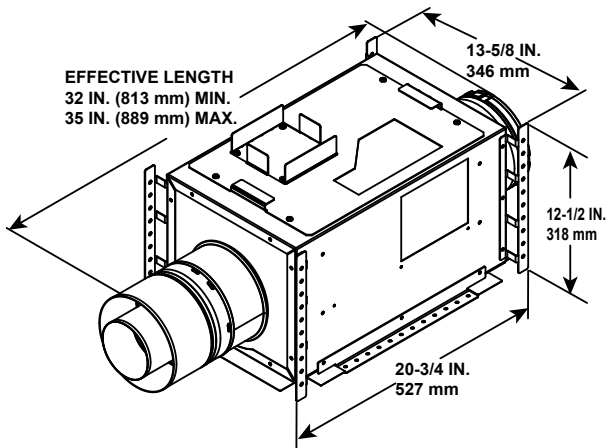

**PVI-SLP-B**  
Power Vent Inline

Optional Wire Harness	
DESCRIPTION	PART NUMBER
10 FT PV Wire Harness	PVI-WH10
20 FT PV Wire Harness	PVI-WH20
40 FT PV Wire Harness	PVI-WH40
60 FT PV Wire Harness	PVI-WH60
80 FT PV Wire Harness	PVI-WH80
100 FT PV Wire Harness	PVI-WH100

**Note:** Wire harnesses required to power the PVI-SLP-B connect to the appliance and are ordered separately from PVI-SLP-B. Contact your dealer to order.

**Note:** The PVI-SLP-B requires one of the following options to be installed on this appliance.

Option A: IFT-RC400 **OR**

Option B: IFT-RC150 and IFT-ACM.

These accessories are purchased separately from the PVI-SLP-B. Contact your dealer to order.

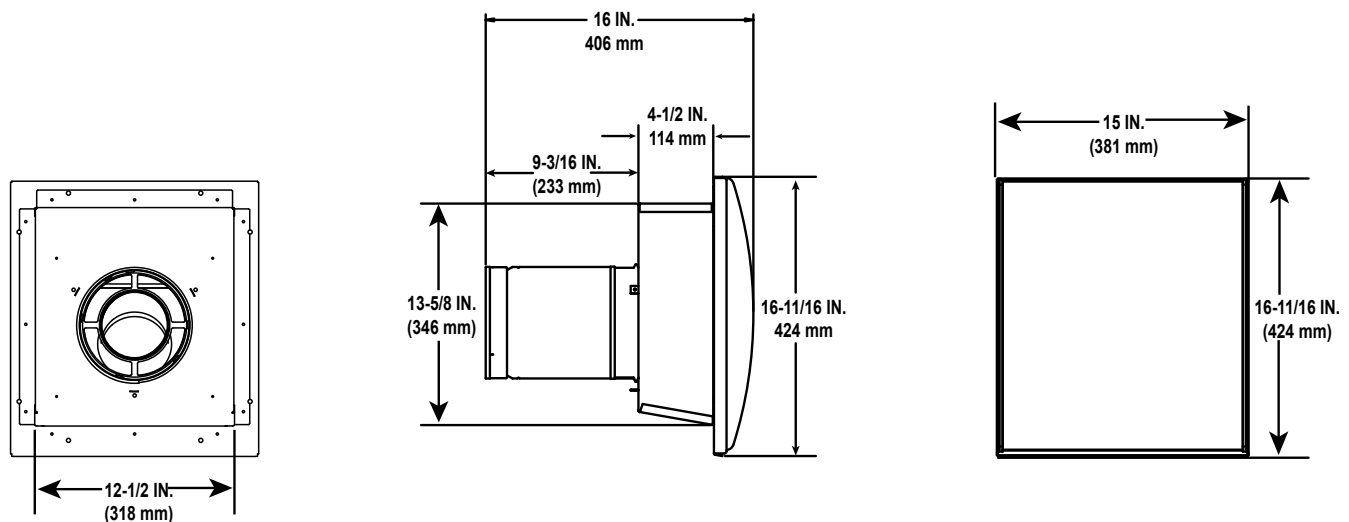

**SLP-LPC**  
SLP Low Profile Cap  
(Approved for use with PVI-SLP-B only)

Figure 12.6 PVI-SLP-B Vent Components

## A. Vent Components Diagrams (continued)

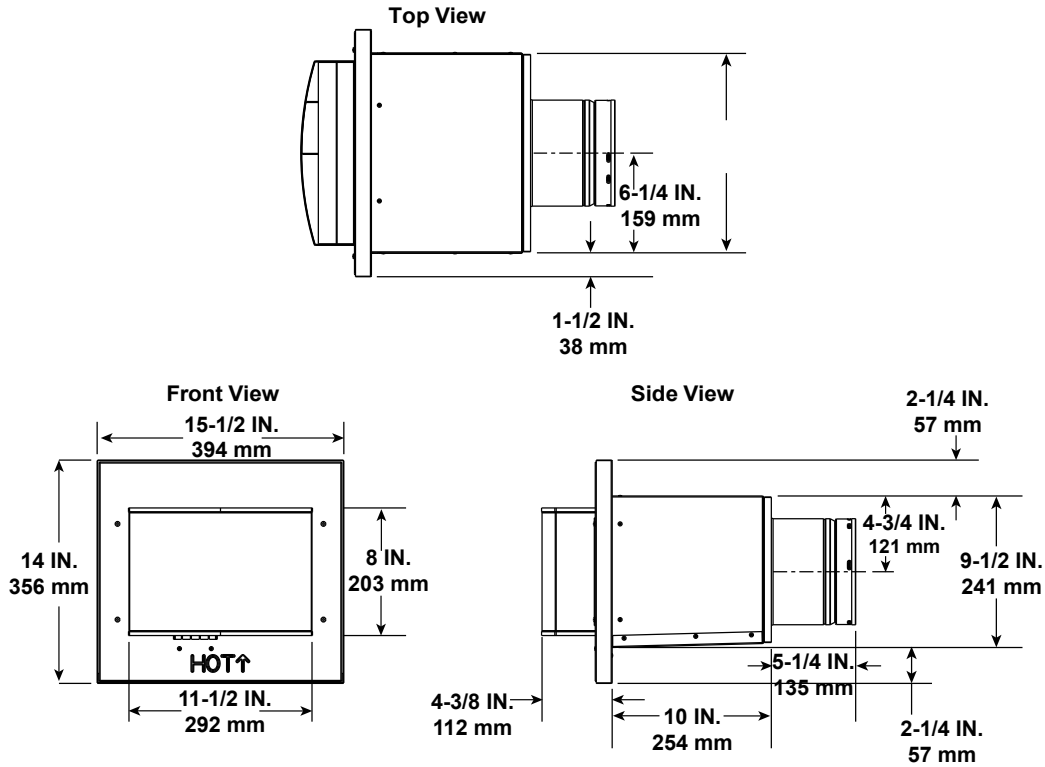

**PVLP-SLP**  
Power Vent Low Profile

**Note:** Wire harnesses required to power the PVLP-SLP connect to the appliance and are ordered separately from PVLP-SLP. Contact your dealer to order.

**Note:** A PVLP-HS heat shield is available and sold separately. Use if the PVLP-SLP is installed in a high traffic area.

**Note:** The PVLP-SLP requires one of the following options to be installed on this appliance.

Option A: IFT-RC400 **OR**

Option B: IFT-RC150 and IFT-ACM

These accessories are purchased separately from the PVLP-SLP. Contact your dealer to order.

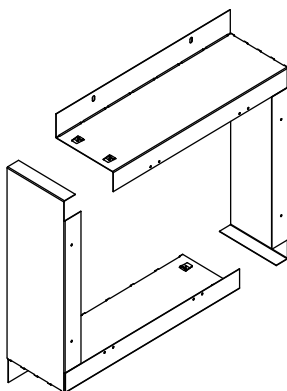

**PVLP-BEK**  
Brick Kit

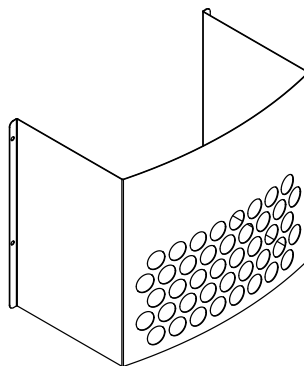

**PVLP-HS**  
Heat Shield

Required Wire Harness	
DESCRIPTION	PART NUMBER
10 FT PV Wire Harness	PVI-WH10
20 FT PV Wire Harness	PVI-WH20
40 FT PV Wire Harness	PVI-WH40
60 FT PV Wire Harness	PVI-WH60
80 FT PV Wire Harness	PVI-WH80
100 FT PV Wire Harness	PVI-WH100

Figure 12.7 PVLP-SLP Vent Components

## A. Vent Components Diagrams (continued)

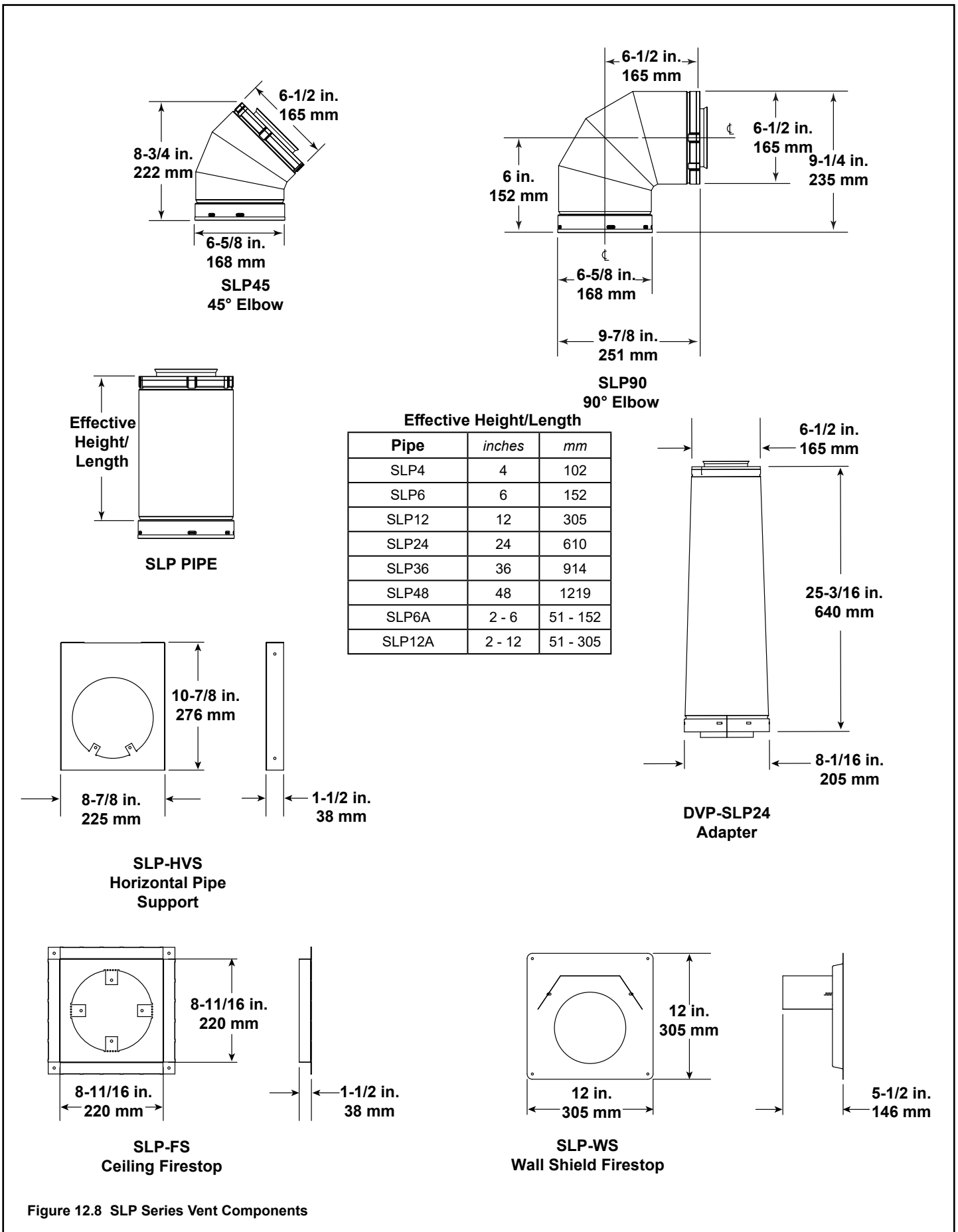
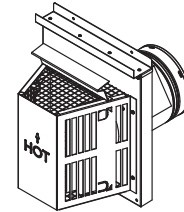
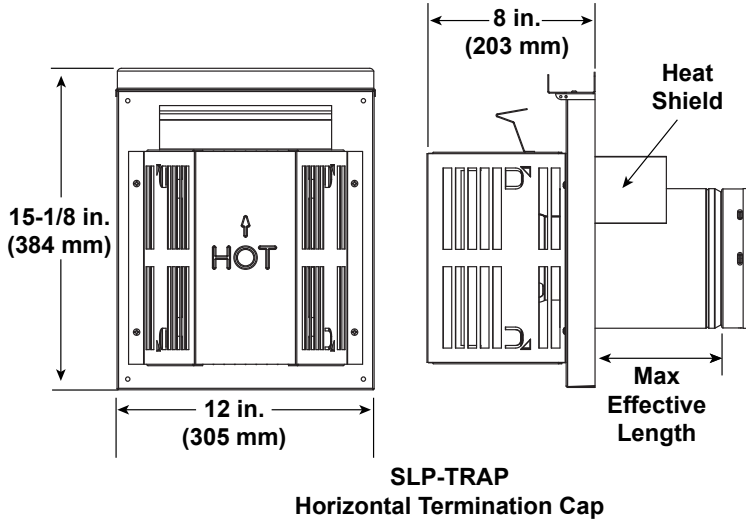

Figure 12.8 SLP Series Vent Components

## A. Vent Components Diagrams (continued)

Note: Heat shields MUST overlap by a minimum of 1-1/2 in. (38 mm). The heat shield is designed to be used on a wall 4 in. to 7-1/4 in. (102 mm to 184 mm) thick. If wall thickness is less than 4 in. (102 mm) the existing heat shields must be field trimmed. If wall thickness is greater than 7-1/4 in. (184 mm) a DVP-HSM-B will be required.



Term Cap	Minimum Effective Length	Maximum Effective Length
Trap1	3-1/8 in.	4-3/4 in.
	79 mm	121 mm
Trap2	5-1/4 in.	9-1/4 in.
	133 mm	235 mm

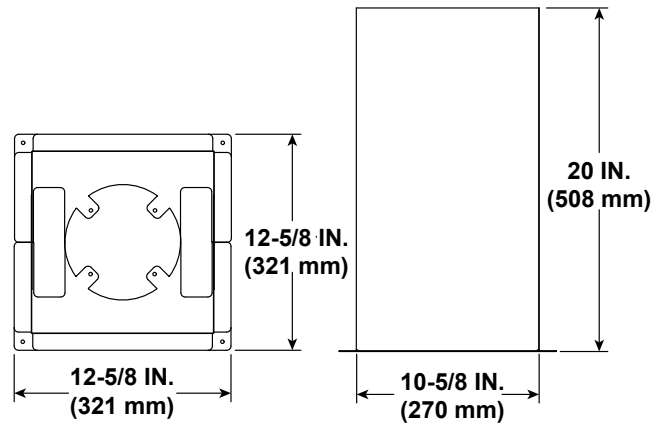
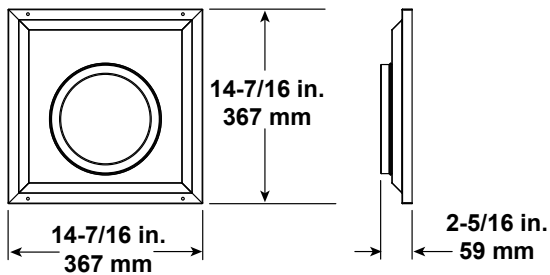
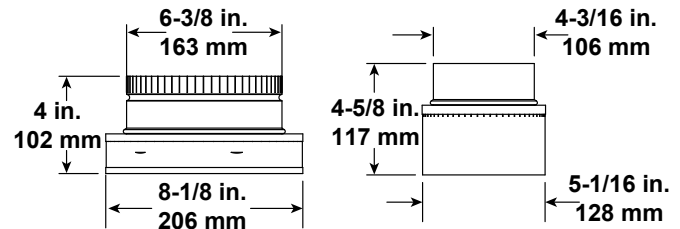
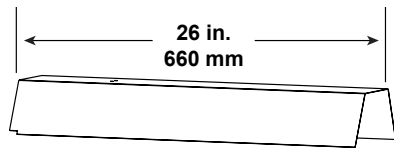
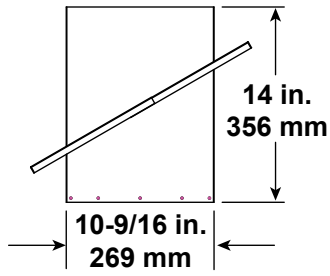

Figure 12.9 SLP Series Vent Components



**A. Vent Components Diagrams (continued)**



**SLP-CCS-BK**  
Cathedral Ceiling  
Support Box-Black

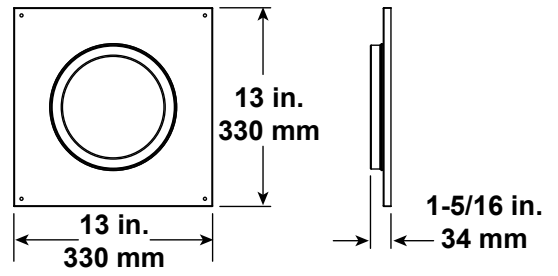

**SLP-DCF-BK**  
Ceiling Firestop  
Black

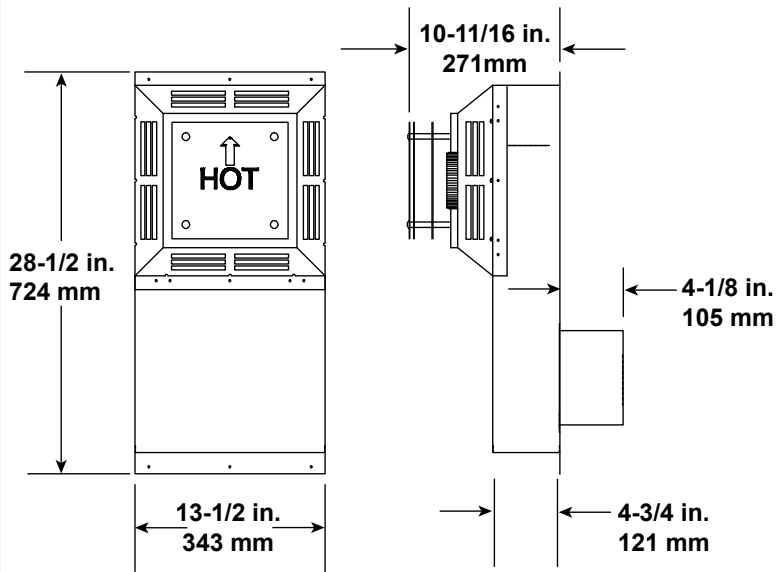

**SLK-SNKD**  
Snorkel  
Termination Cap

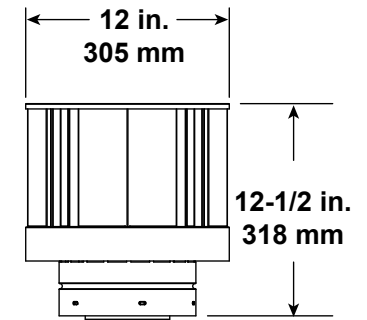

**SLP-TVHW**  
Vertical  
Termination Cap

Figure 12.10 SLP Series Vent Components

## **B. Accessories**

### **Remote Controls, Wall Controls and Wall**

#### **Switches**

Follow the instructions supplied with the control installed to operate your fireplace:

For safety:

- Install a switch lock or a wall/remote control with child protection lockout feature.
- Keep remote controls out of reach of children.

See your dealer if you have questions.

#### **Optional Fan**

Follow the instructions supplied with the fan kit to operate your fan. See your dealer if you have questions.

#### **Optional Heat Management Kits**

Follow the instructions supplied with the kit for operation.

- Preparation of the appliance for installation of a heat management kit is discussed in Section 6.B.

Contact your dealer if you have questions.

Heat & Glo, a brand of Hearth & Home Technologies  
7571 215<sup>th</sup> Street West, Lakeville, MN 55044  
[www.heatnglo.com](http://www.heatnglo.com)

Please contact your Heat & Glo dealer with any questions or concerns.  
For the location of your nearest Heat & Glo dealer,  
please visit [www.heatnglo.com](http://www.heatnglo.com).

*Printed in U.S.A. - Copyright 2022*