

PHOENIX

TRUEVIEW GAS FIREPLACES

HEAT & GLO®



Available IntelliFire®
app and voice control





Phoenix with standard mesh screen and fade-resistant reflective black glass interior

PHOENIX

BIG IMPACT

The Phoenix TrueView series gas fireplace is designed with a large glass-free view and the authentic look of a wood fireplace. Be captivated with beautiful hand-painted logs, glowing LED ember bed and bold flames.

DESIGN FLEXIBILITY

Choose either traditional brick or a modern reflective black glass interior. Safely place a TV 12" above the opening with no mantel required.

COMFORT CONTROL

Stream music or the sound of a crackling fire through optional Bluetooth® speakers for a truly immersive experience. Set the mood with bold flames and mild heat for year round enjoyment. Phoenix. The convenience of gas without the glass.



Phoenix with standard mesh screen and traditional brick interior panels



Phoenix with standard mesh screen and fade-resistant reflective black glass interior panels

INTERIOR OPTIONS AND FEATURES



FADE-RESISTANT REFLECTIVE BLACK GLASS INTERIOR PANELS



TRADITIONAL BRICK INTERIOR PANELS



GLOWING LED EMBER BED



BLACK GRAND VISTA SCREEN DOORS

TECHNOLOGY

INTELLIFIRE TOUCH IGNITION SYSTEM



IntelliFire Touch is our most advanced intermittent-pilot ignition (IPI) system, making operating your appliance simple, smart and safe. Select the IntelliFire app, touch-screen remote control or wireless wall switch for the solution that fits your lifestyle.

WHISPERTONE TECHNOLOGY



Patent-pending system allows airflow with minimal sound, the ability to terminate horizontally for fireplace location flexibility, and an automatic damper which stops air movement when the fireplace is off, preventing cold air infiltration into the home.

OPTIONAL BLUETOOTH SPEAKER



Hear the sound of crackling flames or music for a truly immersive experience.

CONTROLS

INTELLIFIRE APP

All the features of a remote control with an app installed on your smart device. Monitor your fire from anywhere or even control it with the sound of your voice. IntelliFire is compatible with voice assistants Amazon Alexa and Google Assistant.



TOUCHSCREEN REMOTE

Features: on/off, fan speed, lights adjustment, thermostat mode, room temperature readout, child lock, timer mode, battery backup, cold climate mode, power vent, wall docking station (fan, lights and power vent are dependent on your fireplace).



WIRELESS WALL SWITCH

Features: on/off, battery strength indicator, cold climate mode.



SPECIFICATIONS

| MODEL | FRONT WIDTH (A) | | HEIGHT (B) | | DEPTH (C) | | REAR WIDTH (D) | | VIEWING AREA (E X F) | BTU/HR INPUT |
|---------------|-------------------|-------------------|-------------------|-------------------|------------------|--------------|------------------|-------------------|-------------------------------|--------------|
| | ACTUAL | FRAMING | ACTUAL | FRAMING | ACTUAL | FRAMING | ACTUAL | FRAMING | | |
| PHOENIX42-IFT | 50-3/8" [1280] | 51-3/8" [1305] | 74-1/8" [1883] | 74-5/8" [1895] | 28-1/2" [724] | 28" [711] | 34-5/8" [879] | 51-3/8" [1305] | 42" x 28-1/2" [1068 x 723] | 65,000 |

PRODUCT DIMENSIONS

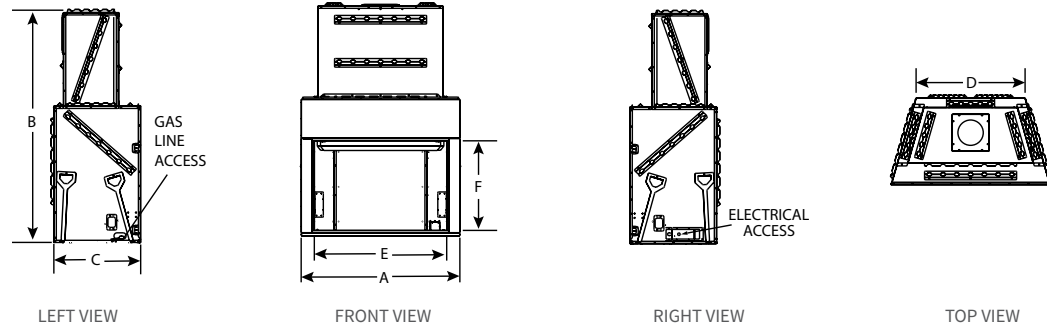

FRAMING & CLEARANCE DIMENSIONS

| A | B | C | D | E* | F | G | H | I |
|-------------------|--------------|-------------------|------------------|-------------------|-----------|-----------|--------------|--------------|
| 74-5/8" [1895] | 28" [713] | 51-3/8" [1305] | 29-3/4" [737] | 51-1/4" [1302] | 0" [0] | 0" [0] | 30" [762] | 36" [914] |

*Frame down to fireplace after unit is installed.

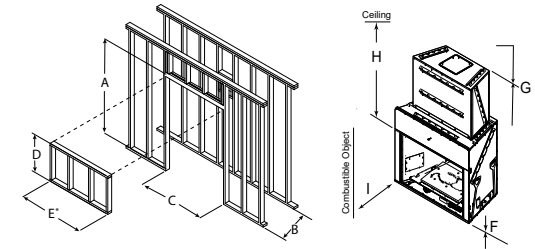

Dimensions are in inches and millimeters. Product information is not complete and is subject to change without notice. Product installation must adhere strictly to instructions shipped with product. We recommend measuring individual units at installation. NOTE: Combustible material should not cover the face. REFER TO INSTALLATION MANUAL FOR DETAILED SPECIFICATIONS ON INSTALLING THIS PRODUCT. Hearth & Home Technologies reserves the right to update units periodically. Actual product appearance, including flame, may differ from product images.

EFFICIENCIES EnerGuide (CSA P.4.1-15) EnerGuide is a rating used in Canada to measure annual fireplace efficiency.

| |
|----------------|
| PHOENIX |
| 19.8% (NG) |

For complete information on this model, please contact us at:



No one builds a better fire

Web: heatnglo.com
Phone: (888) 427-3973 (952) 985-6000
Email: info@heatnglo.com

- [facebook.com/HeatandGlo](https://www.facebook.com/HeatandGlo)
- twitter.com/HeatandGlo
- [youtube.com/HeatandGlo](https://www.youtube.com/HeatandGlo)

HNG-1152U-0423

LIMITED LIFETIME WARRANTY¹

The strongest in the industry, Heat & Glo provides a limited lifetime warranty on the most important aspects: firebox and heat exchanger.

¹: For full warranty details see heatnglo.com. Fireplace surfaces get extremely HOT and can cause severe burns if touched. Keep a safe distance away. To learn more visit www.heatnglo.com/fireplace-safety

Google, YouTube and Google Home are trademarks of Google LLC. Amazon, Alexa, and all related logos are trademarks of Amazon.com, Inc. or its affiliates.

