

Allusion Series:

Model(s):

SF-ALL40-BK
SF-ALL48-BK
SF-ALL60-BK
SF-ALL84-BK

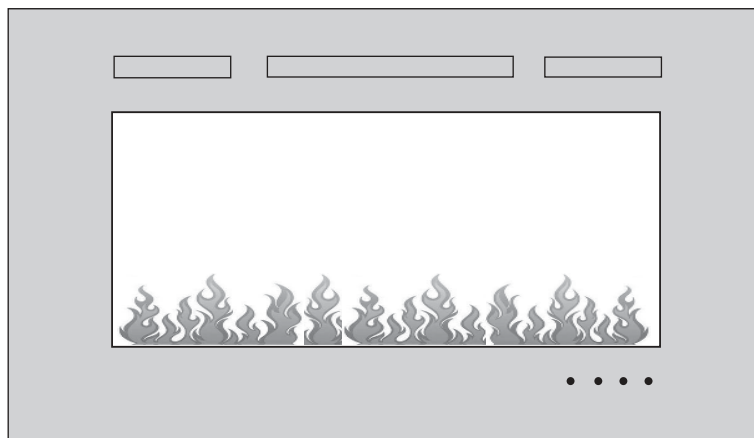

NOTICE



DO NOT DISCARD THIS MANUAL

- Important operating and maintenance instructions included.
- Read, understand and follow these instructions for safe installation and operation.
- Leave this manual with party responsible for use and operation.

**DO NOT
DISCARD**

Congratulations!

Congratulations on selecting a SimpliFire Electric Fireplace, an elegant and clean alternative to wood & gas burning fireplaces. The SimpliFire electric fireplace you have selected is designed to provide the utmost in safety, reliability, and efficiency.

READ CAREFULLY BEFORE ATTEMPTING TO ASSEMBLE, INSTALL, OPERATE, OR MAINTAIN THIS PRODUCT.

PROTECT YOURSELF AND OTHERS BY OBSERVING ALL SAFETY INFORMATION. FAILURE TO COMPLY WITH INSTRUCTIONS COULD RESULT IN PERSONAL INJURY AND/OR PROPERTY DAMAGE.

⚠ WARNING: To reduce risk of fire, electrical shock, or personal injury, read all instructions before using appliance.

SimpliFire, a brand of Hearth & Home Technologies
7571 215th Street West, Lakeville, MN 55044
www.hearthnhome.com

Printed in China - Copyright 2022

1 IMPORTANT INSTRUCTIONS

IMPORTANT SAFETY INSTRUCTIONS

WARNING! Risk of Fire! Risk of Burns! Risk of Electrical Shock!

DO NOT:

- Install or operate damaged heater
- Modify heater
- Operate the heater without fully assembling all components

Hearth & Home Technologies disclaims any responsibility for, and the warranty and agency listing

will be voided by the above actions.

WARNING! DO NOT operate appliance before reading and understanding operating instructions. Failure to operate appliance according to operating instructions could cause fire or injury.

WARNING! Improper installation, adjustment, alteration, service or maintenance can cause injury or property damage. Failure to install appliance according to Owner's Manual could cause property damage or injury.

NOTICE! This appliance is not intended for use as a primary heat source and should not be factored as such in residential heating calculations.

When using electrical appliances, basic precautions should always be followed to reduce the risk of fire, electric shock, and injury to persons, including the following:

- Read all instructions before installing this appliance.
- This appliance is hot when in use. To avoid burns, do not let bare skin touch hot surfaces. Keep combustible materials such as furniture, pillows, bedding, papers, clothes, etc., and curtains at least 3 ft. (0.9 m) from the front of the appliance and keep them away from the sides and rear.
- Extreme caution is necessary when any appliance is used by or near children or other at risk individuals and whenever the appliance is left operating and unattended.
- Do not operate any appliance if it malfunctions. Disconnect power at service panel and have appliance inspected by a reputable electrician before reusing.
- Do not insert or allow foreign objects to enter any ventilation or exhaust opening as this may cause an electric shock, fire, or damage the appliance.
- To prevent a possible fire, do not block appliance fan air intakes or exhaust in any manner.
- A heater has hot and sparking parts inside. Do not use it in areas where gasoline, paint, flammable vapors or liquids are used or stored.
- Use this appliance only as described in this manual. Any other use not recommended by the manufacturer may cause fire, electric shock, or injury to persons.
- Do not operate any appliance with a damaged cord, plug after the appliance malfunctions, has been dropped or damaged in any manner. Return appliance to authorized service facility for examination, electrical or mechanical adjustment or repair.
- Do not use outdoors.
- Never locate appliance where it may fall into a bathtub or water container.
- Do not run cord under carpeting. Do not cover cord with throw rugs, runners, or the like. Arrange cord away from traffic areas and where it will not be tripped over. Do not tightly coil cord.
- Always use properly grounded, fused and polarized outlets.
- Always use ground fault protection where required by electrical code.
- To disconnect appliance, turn controls to "OFF" then remove plug from outlet.
- Always disconnect power before performing any cleaning, maintenance or relocation of the appliance.
- To prevent electrical shock or fire, always use a certified electrician should new circuits be required.
- When transporting or storing the appliance, keep in a dry place free from excess vibration to avoid damage.
- Avoid use of an extension cord because an extension cord may overheat and cause a fire. However if you have to use an extension cord, the cord should be No. 14 AWG minimum size and rated to not less than 1875 watts.

SAVE THESE INSTRUCTIONS

▲ Safety Alert Key:

- **WARNING!** Indicates a hazardous situation which, if not avoided could result in death or serious injury.
- **CAUTION!** Indicates a hazardous situation which, if not avoided, could result in minor or moderate injury.

Table of Contents

Congratulations! 1

1 IMPORTANT INSTRUCTIONS

A. Warranty 4

2 GENERAL INFORMATION

A. Appliance Certification 6
B. Unpacking and Inspecting Appliance 6
C. Model and Serial Number Information 6

3 GETTING STARTED

A. Parts and Hardware 7
B. Tools and Supplies Needed 7
C. Appliance Dimensions 8
D. Location 9
E. Clearance to Combustibles 9
F. Electrical Supply Circuit Requirements 9

4 INSTALLATION

A. Appliance Preparation 11
B. Recessed in 2 x 6 Framed Wall 11
C. Recessed in 2 x 4 Framed Wall 12
D. Direct Wall Mounting with Wall Mounting Bracket 13
E. Electrical Connection / Installation 15
F. Appliance Final Setup 17

5 OPERATING INSTRUCTIONS

A. Manual Switch Function 18
B. Operating by Remote Control 19
C. Room Temperature and Thermostat Function 20
D. Resetting Temperature Cutoff Switch 20

6 MAINTENANCE

A. Maintenance 21
B. Cleaning 21
C. Servicing 21
D. SimpliFire Troubleshooting Guide 22
E. Service Parts List 24
F. Contact Information 28

A. Warranty

Hearth & Home Technologies LLC

LIMITED LIFETIME WARRANTY

Hearth & Home Technologies LLC (“HHT”) extends the following warranty for HHT gas, wood, pellet and electric hearth appliances (each a “Product” and collectively, the “Product(s)”) and certain component parts set forth in the table below (“Component Part(s)”) that are purchased from a HHT authorized dealer or distributor.

WARRANTY COVERAGE:

HHT warrants that the Products and their Component Parts will be free from defects in materials and workmanship for the applicable period of Warranty coverage set forth in the table below (“Warranty Period”). If a Product or Component Parts are found to be defective in materials or workmanship during the applicable Warranty Period, HHT will, at its option, repair the applicable Component Part(s), replace the applicable Component Part(s), or refund the purchase price of the applicable Product(s). The maximum amount recoverable under this Warranty is limited to the purchase price of the Product. This Warranty is transferable from the original purchaser to subsequent owners, but the Warranty Period will not be extended in duration or expanded in coverage for any such transfer. This Warranty is subject to conditions, exclusions, and limitations as described below.

WARRANTY PERIOD:

Warranty coverage begins at the date of installation. In the case of new home constructions, Warranty coverage begins on the date of first occupancy of the dwelling or six months after the sale of the Product(s) by an independent, authorized HHT dealer or distributor, whichever occurs earlier. However, the Warranty coverage shall commence no later than 24 months following the date of Product shipment from HHT, regardless of the installation or occupancy date.

The term “Lifetime” in the table below is defined as: 20 years from the beginning date of warranty coverage for gas appliances, 10 years from the beginning date of warranty coverage for wood and pellet appliances, and 5 years from the beginning of warranty coverage for standalone gas log sets. These time periods reflect the minimum expected useful lives of the designated Component Parts under normal operating conditions.

Warranty Period		HHT Manufactured Appliances and Venting					
Component Parts	Labor	Gas	Pellet	Wood	Electric	Venting	Component Parts Covered by this Warranty
1 Year		X	X	X		X	All parts including handles, external enameled components and other material except as covered by Warranty Conditions, Warranty Exclusions, and Warranty Limitations listed
2 Years					X		All parts except as covered by Warranty Conditions, Warranty Exclusions, and Warranty Limitations listed
2 years			X	X			Igniters, Auger Motors, Electronic Components, and Glass
		X					Electrical components limited to modules, remotes/wall switches, valves, pilots, blowers, junction boxes, wire harnesses, transformers and lights (excluding light bulbs)
		X		X			Molded Refractory Panels, Glass Liners
3 years			X				Firepots, burnpots, mechanical feeders/auger assemblies
5 years		X					Burners and logs for standalone gas log sets (Vented and Vent Free gas log sets not sold as components of the fireplace or stove)
5 years	1 year	X					Vent Free Burners and Vent Free Log components of HHT manufactured fireplaces or stoves
			X	X			Castings, Medallions and Baffles
6 years	3 years			X			Catalysts
7 years	3 years		X	X			Manifold tubes, HHT Chimney and Terminations
10 years	1 year	X					Burners, logs and refractory components of HHT manufactured fireplaces or stoves
Limited Lifetime	3 years	X	X	X			Firebox and heat exchanger, FlexBurn® System (engine, inner cover, access cover and fireback)
1 Year	None	X	X	X	X	X	All purchased replacement parts

WARRANTY CONDITIONS:

- Because HHT cannot control the quality of any Products sold by unauthorized sellers, this Warranty only covers Products that are purchased through an HHT authorized dealer or distributor unless otherwise prohibited by law; a list of HHT authorized dealers is available on the HHT branded websites.
- This Warranty is only valid while the applicable Product remains at the site of original installation.
- This Warranty is only valid in the country in which the HHT authorized dealer or distributor that sold the applicable Product is authorized to sell applicable Product.
- Contact your installing distributor or dealer for Warranty service. If the installing dealer or distributor is unable to provide necessary parts, contact the nearest HHT authorized dealer or supplier. Additional service fees may apply if you are seeking Warranty service from a dealer other than the dealer from whom you originally purchased the applicable Product.
- No HHT consumer should bear cost of warranty service or costs incurred while servicing warranty claims (i.e., travel, gas, or mileage) when the service is performed within the terms of this Warranty. Check with your dealer or distributor in advance for any costs to you when arranging a warranty call. Travel and shipping charges for parts are not covered by this Warranty.

WARRANTY EXCLUSIONS:

This Warranty does not cover the following:

- Changes in surface finishes as a result of normal use. As a heating appliance, some changes in color of interior and exterior surface finishes may occur. This is not a flaw and is not covered under the Warranty.
- Damage to printed, plated, or enameled surfaces caused by fingerprints, accidents, misuse, scratches, melted items or other external sources and residues left on the plated surfaces from the use of abrasive cleaners or polishes.
- Repair or replacement of parts that are subject to normal wear and tear during the Warranty Period are not covered. These parts include: paint, wood and pellet gaskets, firebricks, grates, flame guides, batteries and the discoloration of glass.
- Minor expansion, contraction, or movement of certain parts causing noise. These conditions are normal and complaints related to this noise are not covered by this Warranty.
- Damages resulting from: (1) failure to install, operate, or maintain the applicable Product in accordance with the installation instructions, operating instructions, and listing agent identification label furnished with the applicable Product; (2) failure to install the applicable Product in accordance with local building codes; (3) shipping or improper handling; (4) improper operation, abuse, misuse, continued operation with damaged, corroded or failed components, accident, or improperly/incorrectly performed repairs; (5) environmental conditions, inadequate ventilation, negative pressure, or drafting caused by tightly sealed constructions, insufficient make-up air supply, or handling devices such as exhaust fans or forced air furnaces or other such causes; (6) use of fuels other than those specified in the operation instructions; (7) installation or use of components not supplied with the applicable Product or any other components not expressly authorized and approved by HHT; (8) modification of the appliance not expressly authorized and approved by HHT in writing; and/or (9) interruptions or fluctuations of electrical power supply to the applicable Product.
- Non-HHT venting components, hearth connections or other accessories used in conjunction with the applicable Product.
- Any part of a pre-existing fireplace system in which an insert or a decorative gas applicable Product is installed.
- HHT's obligation under this Warranty does not extend to the Product's capability to heat the desired space. Information is provided to assist the consumer and the dealer in selecting the proper Product for the application. Consideration must be given to the Product location and configuration, environmental conditions, insulation and air tightness of the structure.

This warranty is void if:

- The applicable Product has been over-fired, operated in atmospheres contaminated by chlorine, fluorine, or other damaging chemicals. Over-firing can be identified by, but not limited to, warped plates or tubes, deformation/warping of interior cast iron structure or components, rust colored cast iron, bubbling, cracking and discoloration of steel or enamel finishes.
- The applicable Product is subjected to prolonged periods of dampness or condensation.
- There is any damage to the applicable Product due to water or weather damage which is the result of, but not limited to, improper chimney or venting installation.

LIMITATIONS OF REMEDIES AND LIABILITY:

- **EXCEPT TO THE EXTENT PROVIDED BY LAW, HHT MAKES NO EXPRESS WARRANTIES OTHER THAN THE WARRANTY SPECIFIED HEREIN. The owner's exclusive remedy and HHT's sole obligation under this Warranty or in contract, tort or otherwise, shall be limited to replacement of the Component Part(s), repair of the Component Part(s), or refund of the original purchase price of the applicable Product(s), as specified above; provided, however, that (i) if HHT is unable to provide replacement of the Component Part(s) and repair of the Component Part(s) is not commercially practicable or cannot be timely made, or (ii) the customer is willing to accept a refund of the purchase price of the applicable Product(s), HHT may discharge all such obligations by refunding the purchase price of the applicable Product. In no event will HHT be liable for any incidental or consequential damages caused by defects in the applicable Product. Some States do not allow the exclusion or limitation of incidental or consequential damages, so the above limitation or exclusion may not apply to you. This Warranty gives you specific legal rights and you may also have other rights which vary from State to State. THE DURATION OF ANY IMPLIED WARRANTY IS LIMITED TO DURATION OF THE EXPRESSED WARRANTY SPECIFIED ABOVE FOR THE APPLICABLE PRODUCT. Some States do not allow limitations on how long an implied warranty lasts, so the above limitation may not apply to you.**

2 GENERAL INFORMATION

A. Appliance Certification

MODELS: SF-ALL40-BK, SF-ALL48-BK,
SF-ALL60-BK, SF-ALL84-BK
LABORATORY: CSA International
TYPE: Electric Air-Heaters; Fixed and Location-Dedicated
Electric Room Heaters
STANDARD: CSA C22.2 No 46-2013; UL 2021 (4th Edition)

NOTICE: This installation must conform with local codes.

NOT INTENDED FOR USE AS A PRIMARY HEAT SOURCE.
This appliance is tested and approved as either supplemental room heat or as a decorative appliance. It should not be factored as primary heat in residential heating calculations.

Note: The device complies with Part 15 of the FCC Rules. Operation is subject to the following two conditions:

1. This device may not cause harmful interference, and
2. This device must accept any interference received, including interference that may cause undesired operation.

This equipment uses and can radiate radio frequency energy and, if not installed and used in accordance with the instructions, may cause harmful interference to radio or television reception, which can be determined by turning the equipment off and on. The user is encouraged to try to correct the interference by one or more of the following measures:

- Increase the separation between the equipment and the receiver.
- Connect the equipment into an outlet on a circuit different from that to which the receiver is connected.

 **WARNING:** This product can expose you to Di-(2-ethylhexyl) phthalate, which is known to the State of California to cause cancer and reproductive harm. For more information go to: www.P65Warnings.ca.gov.

B. Unpacking and Inspecting Appliance

WARNING! DO NOT use this Electric Fireplace if any part has been under water. Immediately call a qualified service technician to inspect and to replace any part of the electrical system if necessary. Keep plastic wrapping away from children.

- Carefully remove the appliance and components from the packaging. Discard packaging.
- Carefully inspect components for any damage.
- Reference parts list to verify all parts have been received.
- Read all the instructions before starting the installation. Follow these instructions carefully during the installation to ensure maximum safety and benefit.

C. Model and Serial Number Information

The model and serial number information is located on the rating plate. The rating plate is located on the left side of the top surface of the appliance.

ELECTRIC FIREPLACE		 C US
MODEL	SF-ALLXX-BK	
VOLTAGE	120V AC	
FREQUENCY	60 Hz	
AMPERAGE	12.5 A	
WATTS	1500 W	
SERIAL No.:	_____	600165
Hearth & Home Technologies		MADE IN CHINA

Homeowner Reference Information

We recommend that you record the following pertinent information about your fireplace.

Model Name: _____ Date purchased/installed: _____

Serial Number: _____ Location of fireplace: _____

Dealership purchased from: _____ Dealer Phone: _____

Notes: _____

3 GETTING STARTED

A. Parts and Hardware

Parts and Hardware List	
Part	Quantity
Appliance	1
Glass Panel	1
Instruction Manual	1
Remote Control	1
AAA Battery	2
Fixing Brackets (Shipped attached to appliance with ST4X10 black screw (x4) and black washers (x4))	2
ST3X8 Metal Screws	2
ST6X50 Screws	8
ST4X40 Screws	4
Small Crystal Stones	1
Large Crystal Stones	1
Wall Mounting Bracket with two (2) M5X10 screws - (Only for Direct Wall Mount)	1
Toggle Bolt Anchor	8
Masonry Anchor	8
Power Cord Assembly (Only for Direct Wall Mount)	1

B. Tools and Supplies Needed

Before beginning the installation be sure that the following tools and building supplies are available.

Tape measure

Pliers

Hammer

Gloves

Level

Square

Magnetic Phillips screwdriver

Safety glasses

Drill

Small flat head screwdriver 3/32 in. or smaller (for power cord installation only)

Type NM-B Wire Strain Relief

5/16 in. Drill Bit for 3/16 in. diameter toggle bolts (applicable if installing on drywall-sheathed walls)

Masonry Drill Bit 5/16 in. (applicable if installing on masonry walls)

Concrete screws, or anchors compatible with #10 x 1-1/2 in. long screws, 5/16 in. diameter pilot hole and rated minimum 150 lbs. (only applicable if installing on hollow concrete block wall).

C. Appliance Dimensions

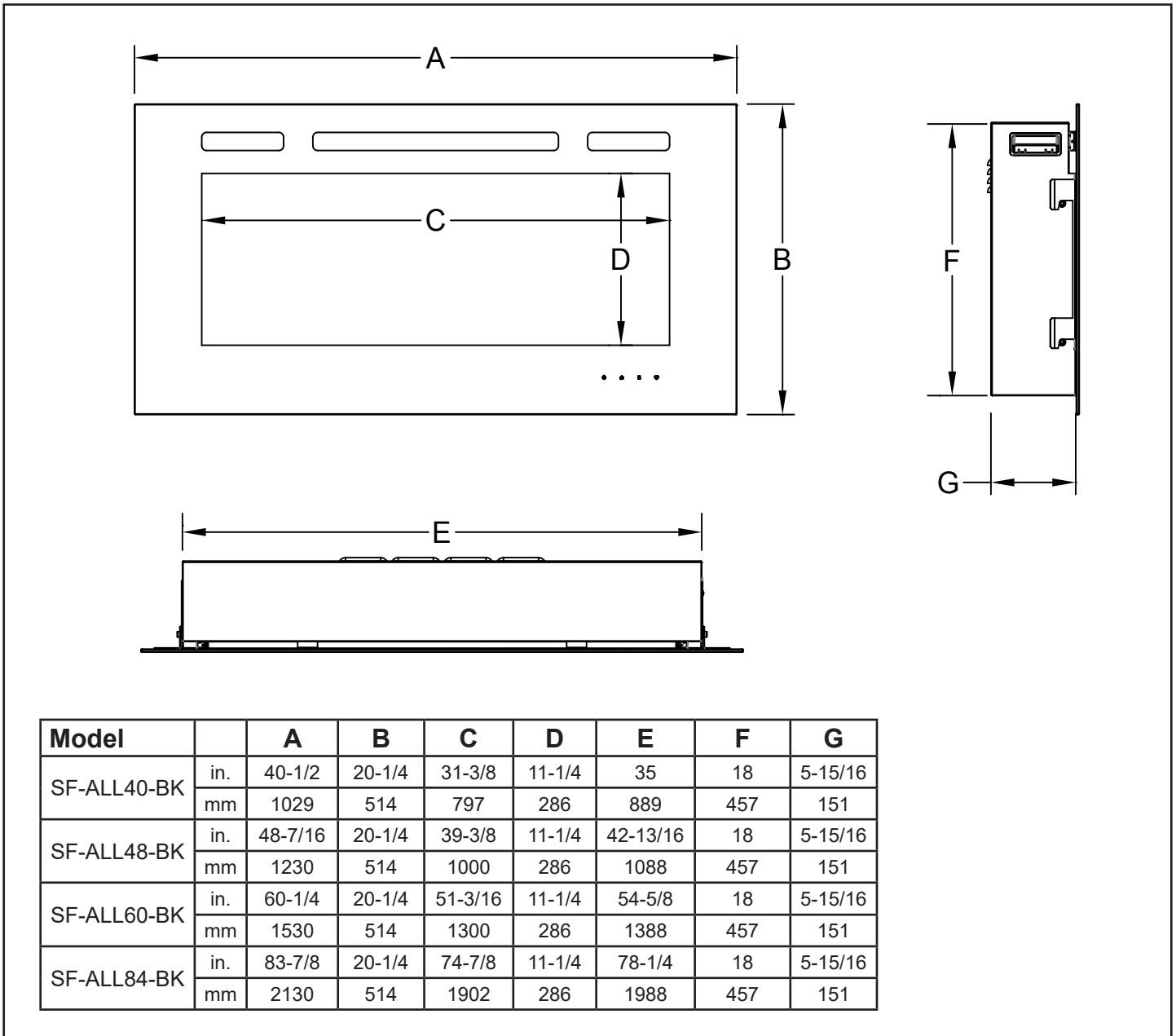

Figure 3.1 Appliance Dimensions

D. Location

Note: If this unit is installed in a bathroom, it must be protected by GFI receptacle or circuit. If receptacle is used it must be readily accessible. This electrical appliance is not water tight. To prevent electrical shock, it must be installed as to prevent water from entering unit. It must be installed away from showers, tubs, or other water sources. Never locate the appliance where it may fall into a bathtub or other water container.

When choosing a location for your fireplace ensure that the following general rules are followed:

- For best results, install out of direct sunlight.
- Power supply service must be installed within proximity of electric fireplace prior to finishing to avoid reconstruction.
- Appliance should be mounted so the front glass panel is located outside the swing arc of adjacent door.
- See Figure 3.2 and 3.3 to determine location of appliance installation.

E. Clearance to Combustibles

Minimum Clearance to Combustible Construction

Sides.....	0 in.
Floor.....	0 in.
Top.....	0 in.
Back.....	0 in.
Front.....	36 in.
Mantel.....	5/8 in.

See Figure 3.2.

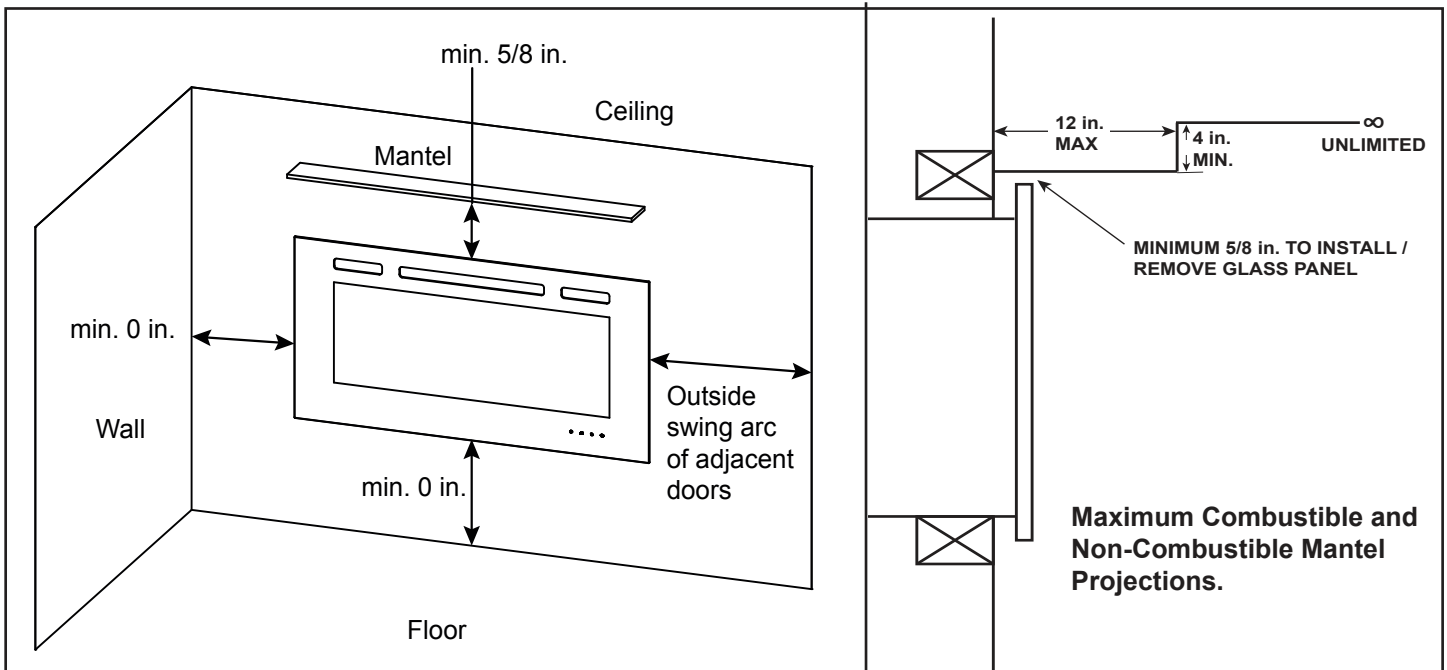

Figure 3.2 Location and Clearances Requirements

WARNING! Risk of Fire! Keep electrical cords, drapery, furnishings or other combustibles at least 3 ft. (0.9 m) from the front of the electric fireplace, and away from the sides or rear.

F. Electrical Supply Circuit Requirements

Plan the location of the appliance so that it will have adequate electric power. A 15 AMP, 120V/60Hz circuit is required. Additional appliances on the same circuit as this appliance may exceed the current rating of that circuit. A dedicated circuit is not required, but is preferred to prevent circuit breaker trips or fuse failure.

Note: If mounting on a wall and using the supplied power cord, choose a location near an outlet so an extension cord is not required.

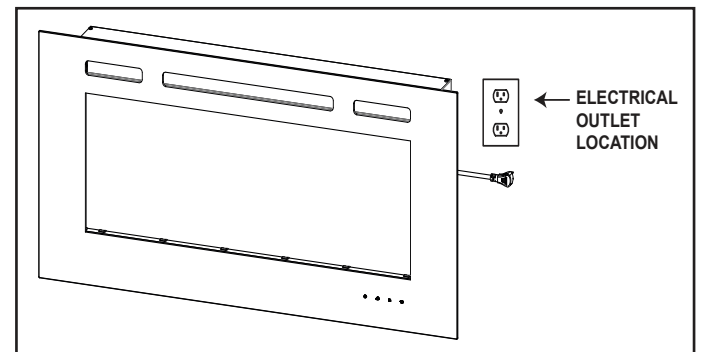

Figure 3.3 Electrical Outlet Location

4 INSTALLATION

WARNING! Risk of Personal Injury or Property Damage! Failure to install the appliance as instructed below may result in damage to the equipment and or may expose the user to the risk of fire, serious injury, illness or death.

NOTICE: These instructions are not substitutes for the requirements of local building codes.

There are three options for the appliance installation:

- Recessed into a 2 x 6 in. wall - Section 4.B.
- Recessed into a 2 x 4 in. wall - Section 4.C.
- Mounted directly on the wall - Section 4.D.

The appliance can be recessed into the wall, but the glass front must overlap the opening in the wall construction. The glass front cannot be finished into the wall, or overlapped with any finishing materials.

When installed in a recessed opening on an exterior wall in cooler climates, a chase may be required by local building codes to accommodate insulation. The chase should be constructed in a manner of all outside walls of the home to prevent cold air drafting problems. The chase should not break the outside building envelop in any manner. Walls, ceiling, baseplate, and cantilever floor of the chase should be insulated. Vapor and air infiltration barriers should be installed in the chase as per regional codes for the rest of the home. Additionally, in regions where cold air infiltration may be an issue, the inside surfaces may be drywalled and taped (or equivalent method may be used) to achieve maximum air tightness.

NOTICE: Insulation and other loose materials must be secured to maintain the air clearance between the appliance and interior envelope of the wall opening. This will ensure that the appliance can circulate air to its room temperature sensor for maximum performance of the Thermostat function.

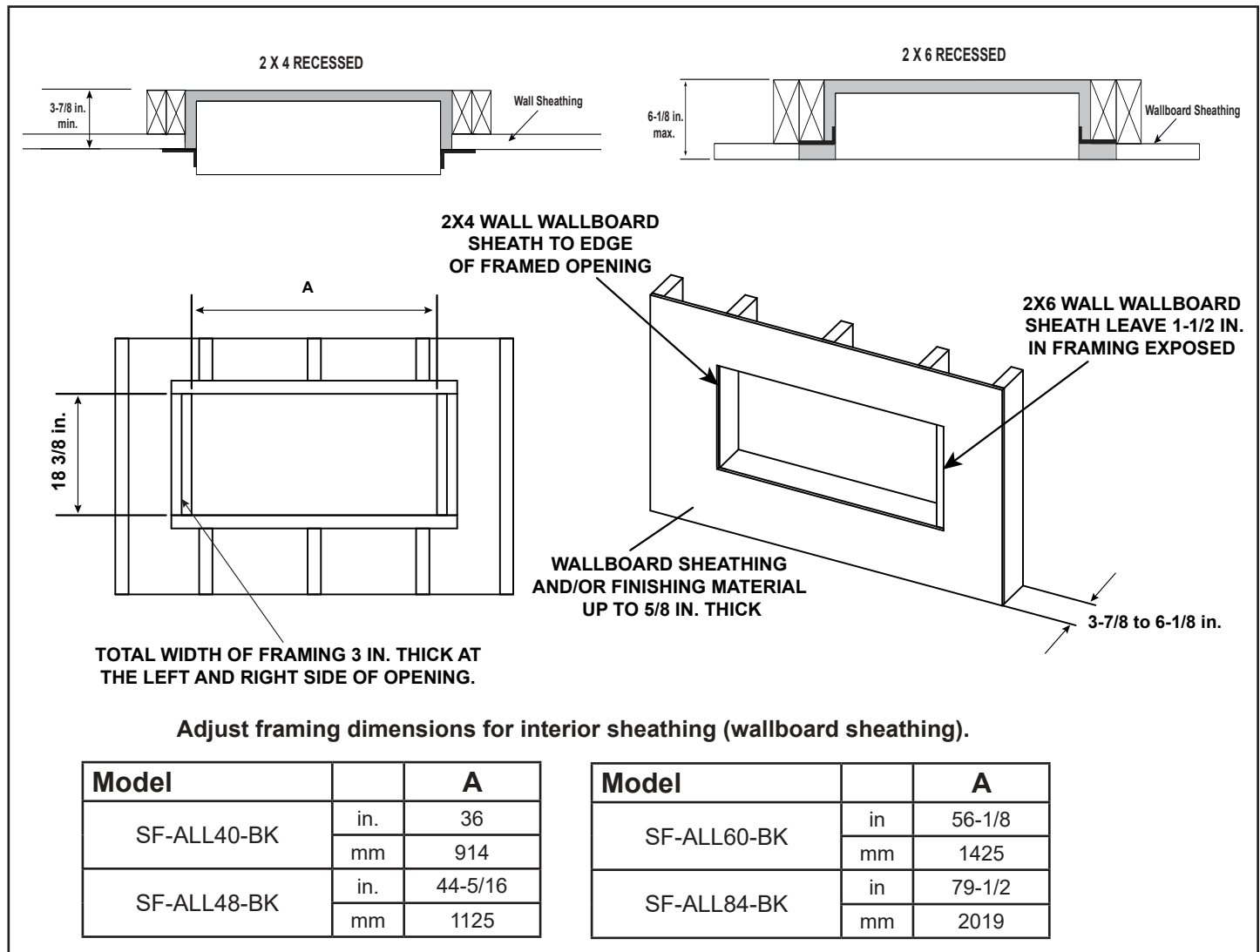

Figure 4.1 Framing and Wall Finishing for Recessed Installation

A. Appliance Preparation

After determining the location and framing dimensions, the appliance must be prepared for installation.

The appliance is shipped with its wall mounting bracket attached. Remove the bracket by removing the two (2) M5X10 screws on the bottom of the appliance, then disengage the bracket from the appliance. Set the wall mounting bracket aside for future use.

If the appliance is to be recessed into 2 X 6 in. framed wall construction, refer to Section 4.B for installation instructions.

If the appliance is to be recessed into 2 X 4 in. framed wall construction, refer to Section 4.C for installation instructions.

If the appliance is to be installed directly to the face of the wall, refer to Section 4.D for installation.

B. Recessed in 2 x 6 Framed Wall

1. Finish wall construction per requirements in Figure 4.1.

The width of the framing on each side of the opening must be 3 in. with 1-1/2 in. framing on the left and right sides of the opening exposed. This is needed for the wallboard finishing and to secure the appliance into the opening. See Figure 4.1.

Allow 1-1/2 in. of wood exposed after finishing the wallboard. See Figure 4.1 and Figure 4.6.

2. Verify that the Fixing Brackets are securely attached to the appliance with four (4) ST4X10 screws and washers. See Figure 4.3. The attachment holes for the brackets into the appliance are slotted to allow adjustment for the thickness of the wallboard and/or any finishing materials up to a total 5/8 in. thick. It may be necessary to test fit the appliance and adjust the location of the brackets on the appliance so that the front face of the unit protrudes 1/16 to 1/8 in. from the outside face of the finished wall. See Figure 4.4 and 4.5.
3. Connect to electrical service. Reference Section 4.E.
4. Install the appliance into the opening so the weight of the appliance is supported by the bottom framing. Level with shims if necessary. Ensure that it is centered left to right, then fasten it directly to the framing with four (4) ST4X40 screws through both the left and right brackets. See Figure 4.6.

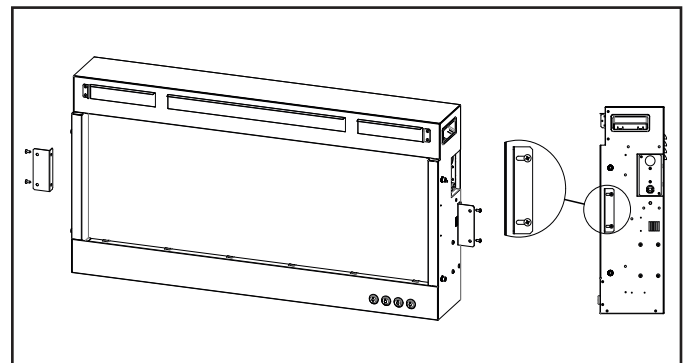

Figure 4.3 Fixing Brackets Attachment for Recessed Mounting in 2 X 6 in. Framing

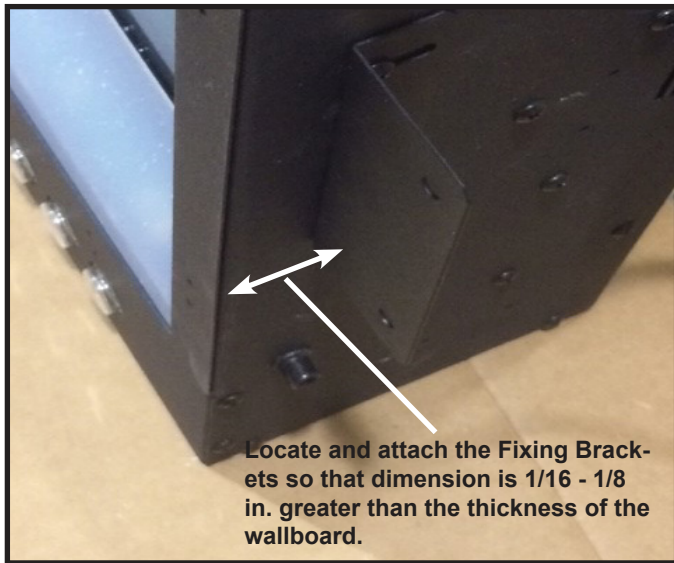

Figure 4.4 Adjust Bracket Location

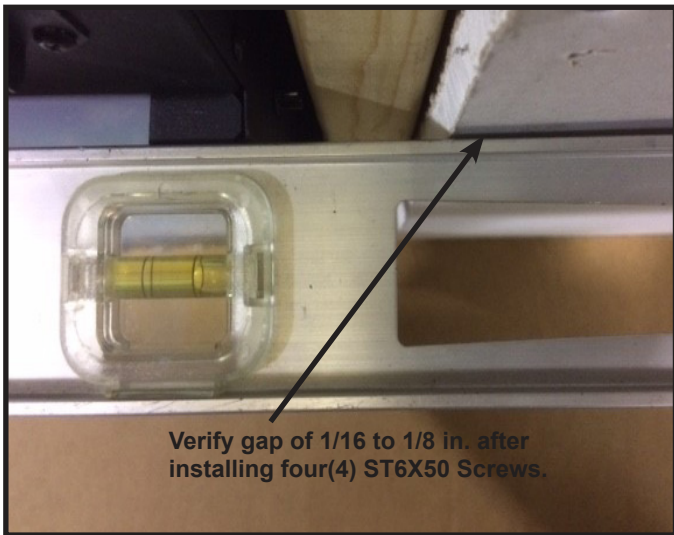

Figure 4.5 Adjust Bracket Location

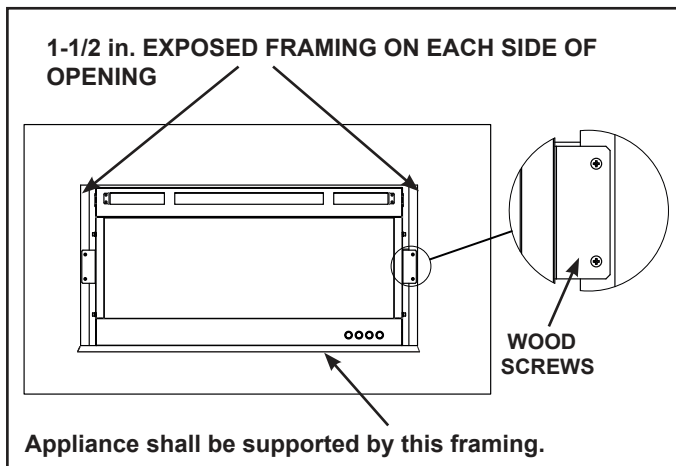

Figure 4.6 Securing the Appliance in 2 X 6 Framing

C. Recessed in 2 x 4 Framed Wall

1. Finish wall construction per requirements in Figure 4.1.

The width of the framing on the left and right sides of the opening must be 3 in.. This is needed for the wallboard finishing and to secure the appliance into the opening. See Figure 4.1 and Figure 4.8.

Wallboard should be finished up to the edge of the framed opening. See Figures 4.1 and 4.8.

2. Install the Fixing Brackets to the right and left side of the appliance. If necessary, remove the Fixing Brackets, and reorient them to the position of 2X4 framing. See Figure 4.1 and 4.7. Attach each Fixing Bracket to the appliance with two (2) ST4X40 screws and washers. See Figure 4.7 for proper bracket orientation.
3. Connect to electrical service. Reference Section 4.E.
4. Install the appliance into the opening so the weight of the appliance is supported by the bottom framing. Level the appliance. Ensure that it is centered left to right, then fasten it directly to the framing with two (2) ST4X40 screws through both the left and right brackets. See Figure 4.8.

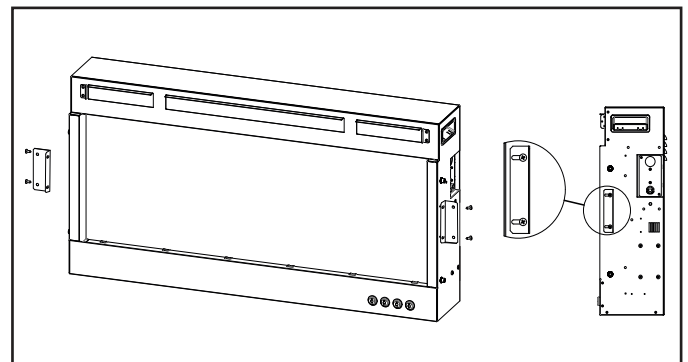

Figure 4.7 Fixing Brackets Attachment for Recessed Mounting in 2 X 4 in. Framing

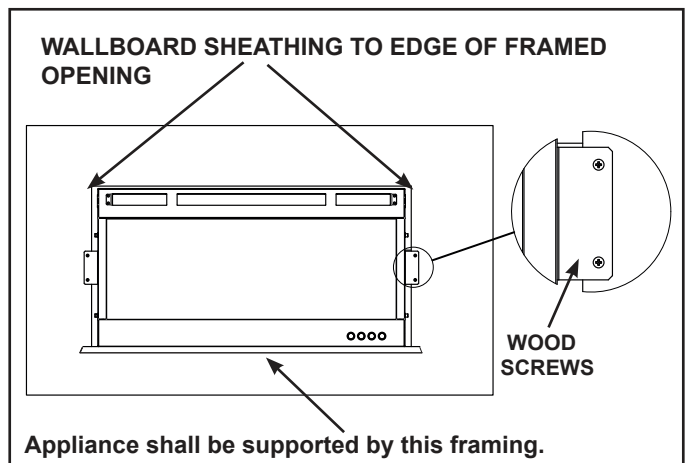

Figure 4.8 Securing the Appliance in 2 X 4 Framing

D. Direct Wall Mounting with Wall Mounting Bracket

The wall mounting bracket can be installed on masonry walls such as those constructed of brick or concrete, or to framed walls constructed of wood or steel framing sheathed with gypsum wallboard, drywall, wood, etc. The method used to mount the mounting bracket is different between masonry walls and framed walls. Refer to the following sections for more detail on the method applicable to this installation.

Framed Wall

- Locate the mounting bracket on the wall in the desired location of the appliance. Level the bracket, then mark its location on the wall, including a marking for each of the fastener holes in the bracket.
- For each of the marked mounting point locations, determine which points align with a structural framing member.
- At the points where a wood or metal framing member exists, the ST6X50 screw can be installed directly into that structural member. See Figure 4.13.
- For every mounting hole that does not align with a structural framing member, a wall board toggle-bolt anchor must be used. See Figure 4.9.

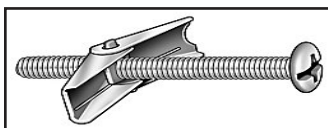

Figure 4.9 3/16 Toggle-Bolt Anchor

- The toggle-bolt anchors are provided to accommodate the required anchor points based on the appliance. Use of toggle bolt anchors requires drywall thickness of minimum 1/2 in. and drilled holes size of 1/2 in. diameter.
- Insert the bolt through the front side of the mounting bracket and thread the toggle onto it from the rear of the bracket. See Figure 4.10.
- Fold the toggle wings flush against the bolt and push them through a drilled hole until the toggle wings expand open on the other side. See Figure 4.11.
- Pull back on the bolt and tighten. See Figure 4.11.

Note: This product cannot be installed on a wall sheathed with drywall less than 1/2 in. thick, unless all required anchor points in the mounting bracket align with structural framing members.

NOTICE: Minimum six screw(s) and/or toggle bolt anchors are required for wall mounting the SF-ALL40-BK, SF-ALL48-BK, and SF-ALL60-BK. Minimum of eight (8) screw(s) and/or toggle bolt anchors are required for wall mounting the SF-ALL84-BK.

WARNING! Risk of Damage or Personal Injury! Allowable pull-out and shear strength are 25% of ultimate values or less, as required by building authorities.



Figure 4.10 Toggle Bolt Installation through Mounting Bracket



Figure 4.11 Installing Anchors in Hollow Wall

Masonry Wall

- Locate the mounting bracket on the wall in the desired location of the appliance. Level the bracket, then mark its location on the wall, including a marking for each of the fastener holes in the bracket.

NOTICE: Minimum six (6) anchored screws are required for wall mounting the SF-ALL40-BK, SF-ALL48-BK, and SF-ALL60-BK. Minimum of eight (8) anchored screws are required for wall mounting the SF-ALL84-BK.

- In the marked locations, drill 5/16 in. diameter x 1-1/2 in. deep holes. See Figure 4.12.

NOTICE: The supplied wall anchors are designed for solid masonry wall such as brick or poured concrete. Do not use the supplied wall anchors when mounting this product to hollow concrete block walls. If mounting this product to concrete block, contact your local building supply retailer to source a fastener system that is compatible with concrete block and rated minimum 120 lbs. load capacity at each required anchor point.

- Insert the provided wall anchors into the holes.
- Gently tap the anchors with a hammer until they are flush with the wall surface.
- With mounting hooks pointed up, attach the bracket to the masonry anchors with ST6X50 screws. See Figure 4.13.

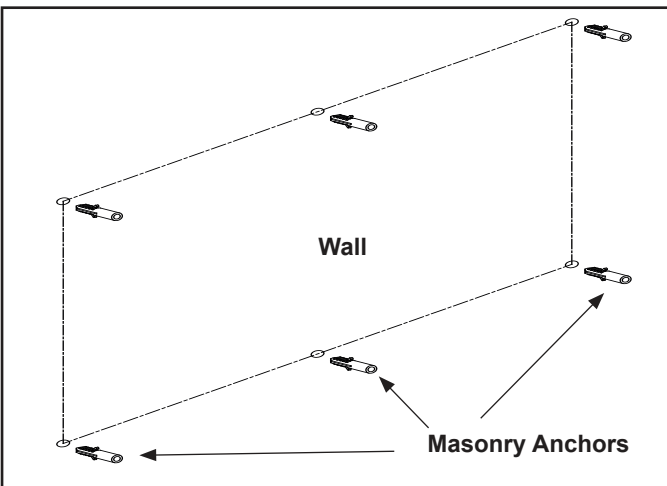

Figure 4.12 Masonry Anchor Placement

WARNING! Risk of Damage or Personal Injury! Do not use supplied masonry anchors on concrete block walls or hollow walls sheathed with wood, gypsum wall-board, drywall, or other materials.

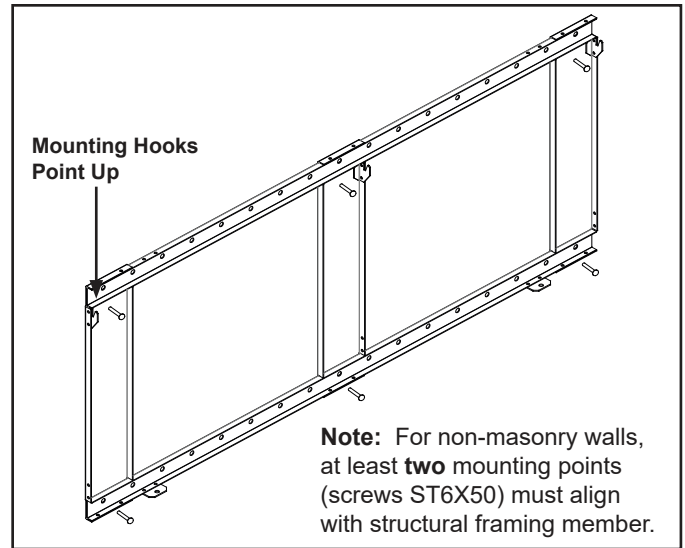

Figure 4.13 Bracket Attachment

Appliance Installation

- Hang appliance on the mounting bracket.
- Align the slots on the back of the appliance with the hooks on the top two corners of the bracket.
- Hang the appliance and pull down to ensure the hooks are fully engaged. See Figure 4.14.
- Secure the appliance to the bracket with two M5X10 screws. See Figure 4.14.

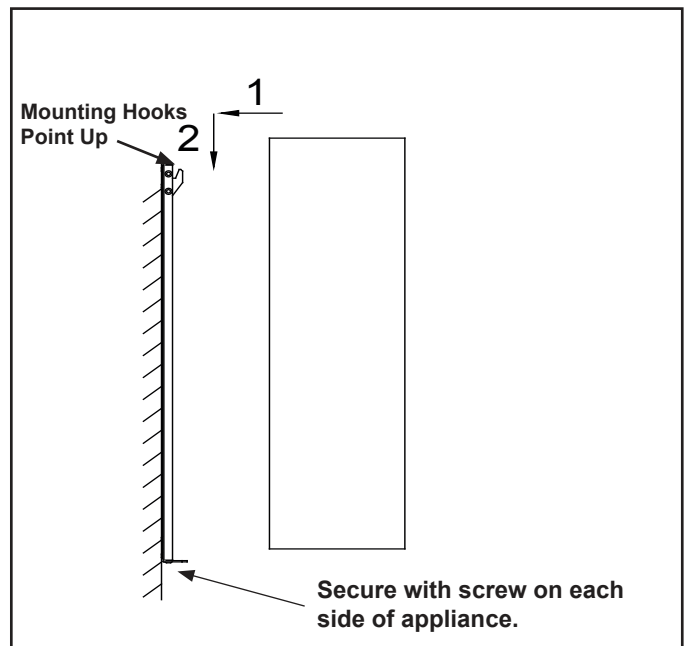

Figure 4.14 Attaching Appliance to Bracket

E. Electrical Connection / Installation

Note: All wiring must be completed prior to finishing the unit.

All electrical connections shall be performed by a qualified electrician.

WARNING! Risk of Fire, Electrical Shock and Injury!
Electrical wiring must comply with local building codes and other applicable regulations.

WARNING! Risk of Shock! Label all wires prior to disconnection when servicing the appliance. Wiring errors can cause improper and dangerous operation. Verify proper operation after servicing.

This appliance has been designed to be hard-wired for 120V. A supplied plug-in kit is also available for applications that will use an electrical outlet receptacle.

A 15 AMP, 120V/60Hz circuit is required. Additional appliances on the same circuit as this appliance may exceed the current rating of that circuit. A dedicated circuit is not required, but is preferred to prevent circuit breaker trips or fuse failure.

Hard-Wired Installation:

Note: The appliance must be electrically connected and grounded in accordance with local codes.

1. Remove terminal block cover plate located on the right end of the appliance.
2. Install a wire strain relief bushing into the cover plate.
3. Terminate type NM-B wire to the terminal block, ensure connections are secure, and tighten the strain relief. Use 3/32 slotted head screwdriver, or equivalent, to depress the spring loaded terminals for the conductors. See Figure 4.15.
4. Replace terminal block cover plate and retaining screws.

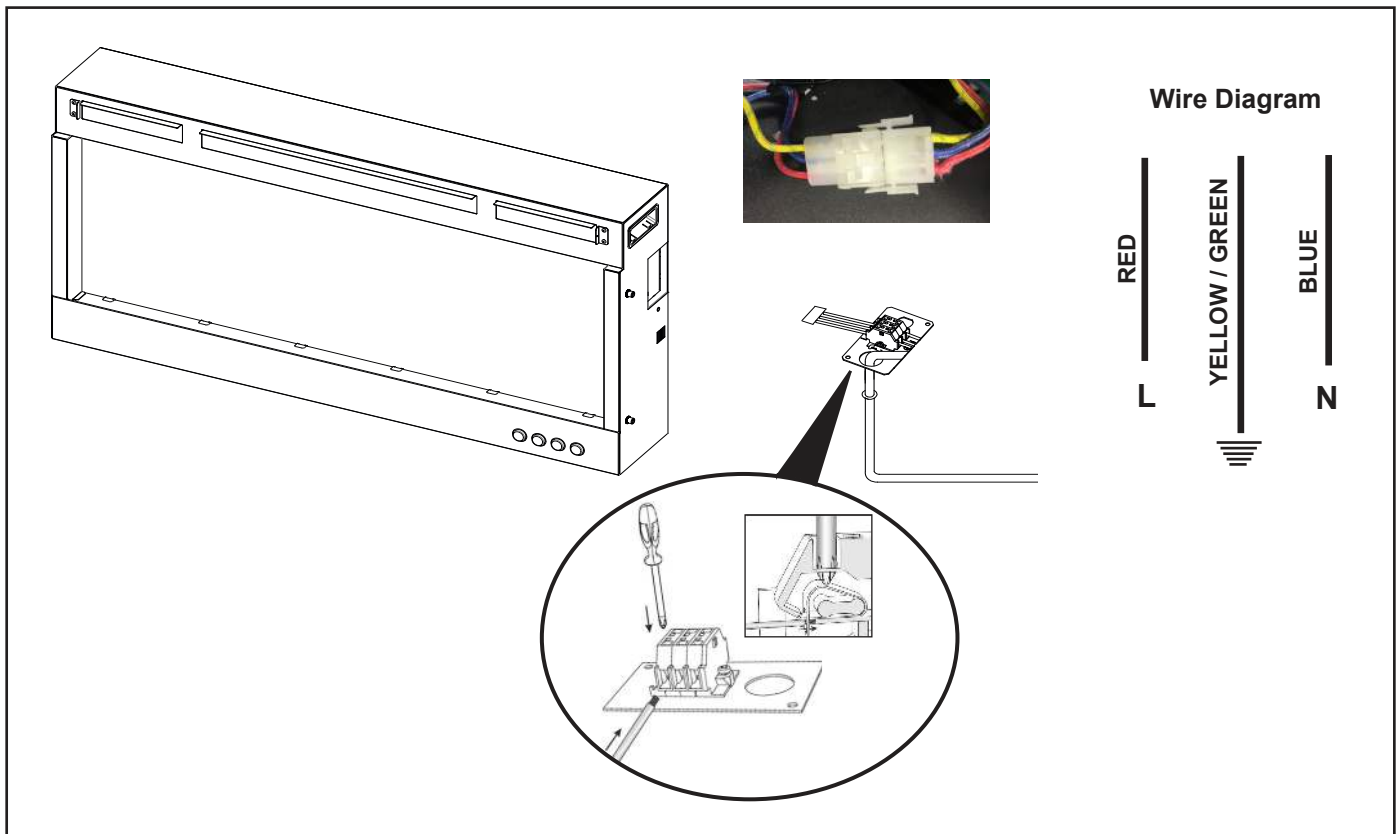

Figure 4.15 Hard-Wired Installation

Power Cord Installation

The appliance power cord has a three pin NEMA-5-15P plug. The power cord should not be used unless a grounded receptacle is available.

1. Remove the terminal block cover plate located on the right end of the appliance.
2. Disconnect the terminal block from the three wires inside the appliance. Wires are released by disconnecting the three conductor wire connector. Discard the terminal block cover plate.
3. Connect the three conductor wire connector to the connector on the block supplied with the power cord kit. See Figure 4.16.
4. Replace cord kit terminal block cover plate and retaining screws. Plug cord into nearest outlet. See Figure 3.3.

WARNING! Risk of Fire, Electrical Shock and Injury!

Ensure the power cord is not installed so that it is pinched or against a sharp edge and ensure that the power cord is stored or secure to avoid tripping and snagging.

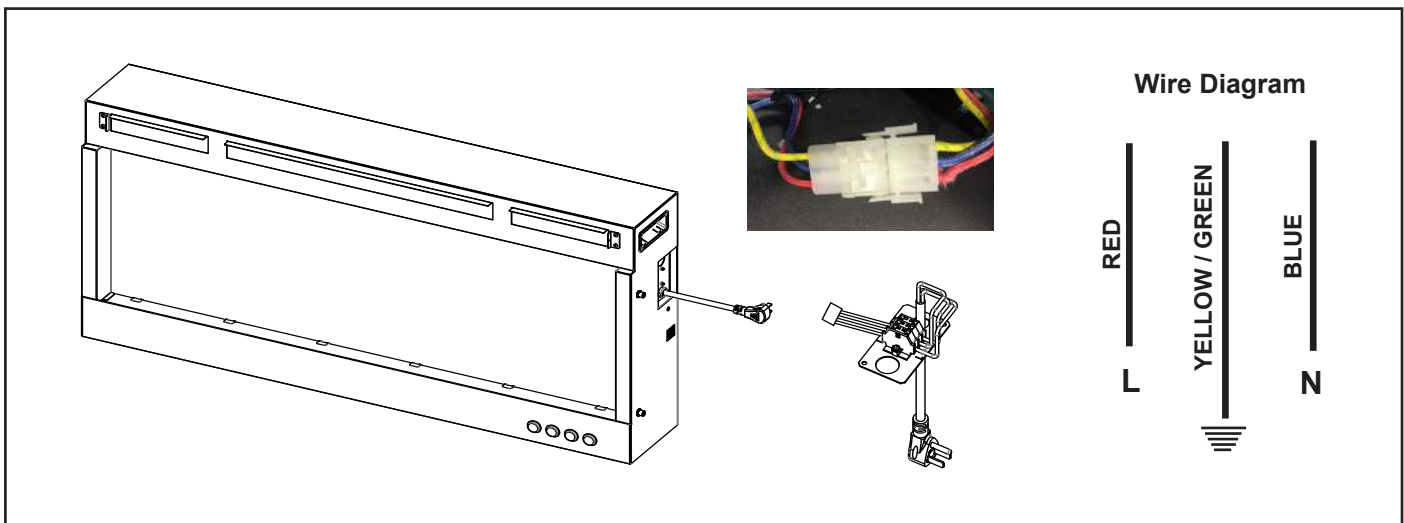

Figure 4.16 Optional Power Cord Assembly

F. Appliance Final Setup

1. Carefully spread the small crystal stones across the ember bed. Then evenly arrange the larger crystal stones along the inset window ledge at the front of the firebox.

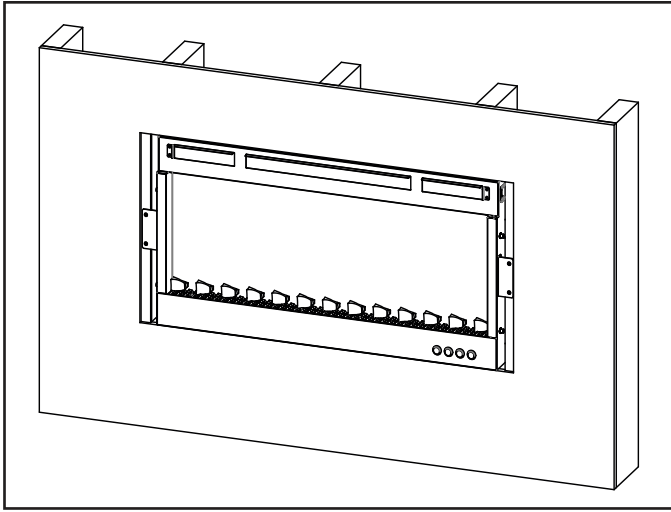

Figure 4.17 Stone Installation

Note: If optional logs are purchased, arrange the logs on top of the crystal stones as desired.

CAUTION! *Two adults are recommended for the installation of glass front. Use caution when handling glass. Failure to do so could result in personal injury or property damage.*

2. Install front panel. Locate the J-hooks on the back side of the glass on the four rivnuts on the appliance opening. Press down on top edge of glass to fully engage J-hooks on the rivnuts. See Figure 4.18.

Note: Make sure the glass is fully attached to the firebox so that the control panel can work properly.

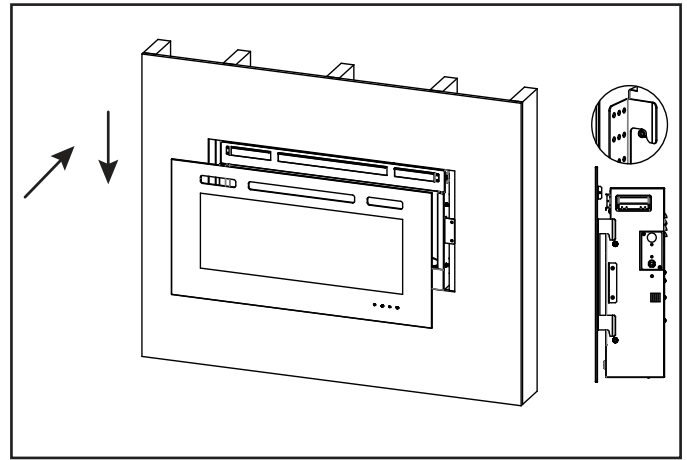

Figure 4.18 Glass Front Installation

3. Thread the two (2) ST3X8 screws into the threaded holes on the glass panel. Check the alignment of the glass panel and securely tighten the screws. See Figure 4.19.

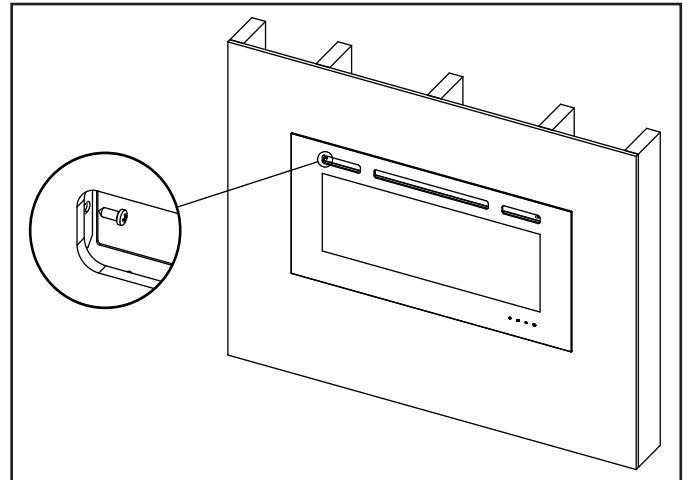

Figure 4.19 Secure Glass Front

5 OPERATING INSTRUCTIONS

CAUTION! The unit's power cord must be connected to a properly grounded and protected 120V outlet. Always use ground fault protection where required by the electrical code.

WARNING! Risk of Fire, Electrical Shock, and Injury! Do not operate the unit if it is damaged or has malfunctioned. If you suspect the unit is damaged, call a qualified service technician to inspect and replace any part of the electrical system if necessary.

A. Manual Switch Function

The appliance can be operated by both remote control and manual buttons. Once the unit has been properly connected to a grounded electrical outlet, turn on the main power switch located on the lower right side of the appliance. A beep should be heard when the power is first applied. See Figure 5.1.

Power Button

The Power button turns the power of the appliance on or off.

Flame Button

By pressing the FLAME button, the unit will cycle through four flame effects.

Heater Button

The HEATER button will cycle from low to high and to off settings.

Ember bed LED Light Button

The Ember Bed LED light button will turn on the LED lights and cycle through 14 color themes (13 colors and a color rotating option).

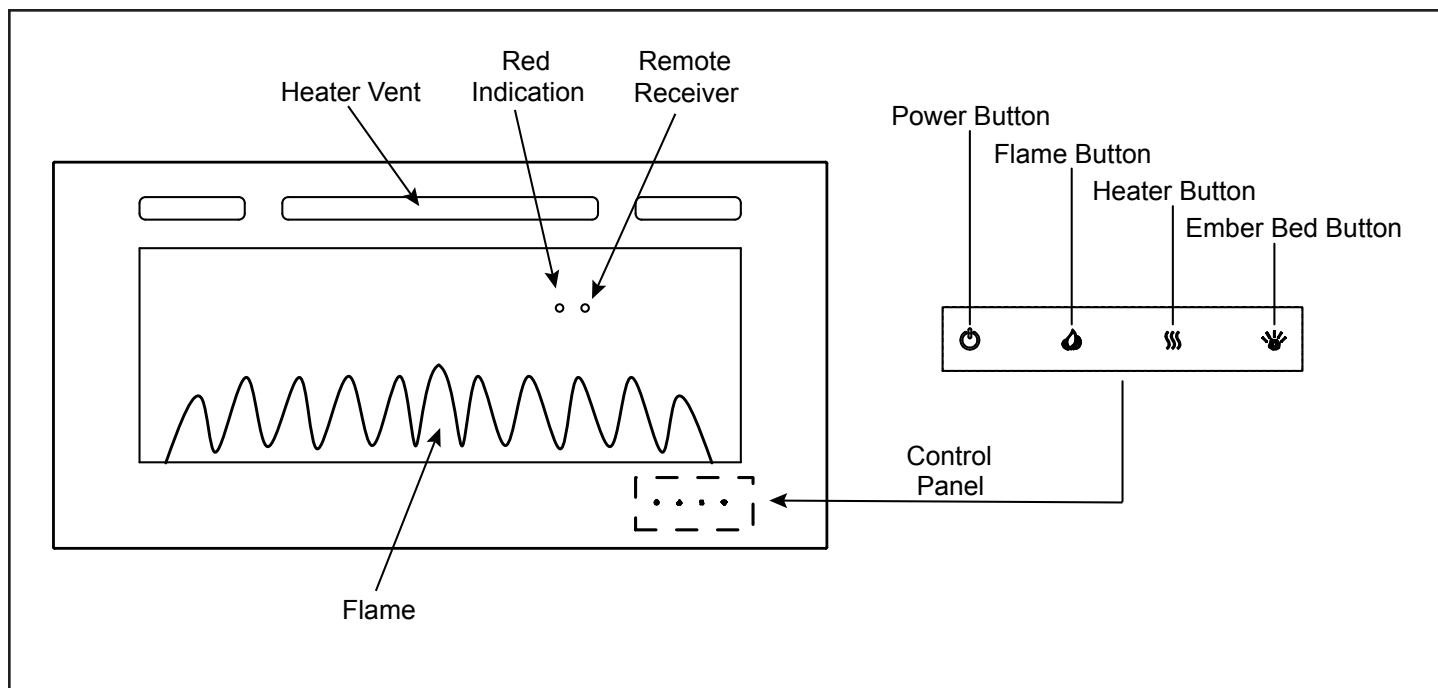



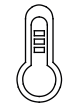



Figure 5.1 Manual Operating Switches

B. Operating by Remote Control

- The appliance Main Power Switch must be in the “ON” position for the remote control to function.
- Make sure batteries are properly installed in Remote Control.
 - Battery requirements 2 x AAA batteries (included).
- The effective range of the remote is up to 16 ft.
- The remote control must be within the 16 ft. range and also be pointed directly at the face of the appliance. For best results, position the remote control within 45 degrees of the face of the appliance

ICON	TITLE	FUNCTION	REMOTE LCD DISPLAY	FIREPLACE RESPONSE
	POWER	The POWER button will turn the fireplace on. It will also put the fireplace in a standby mode. This will turn off all functions at once but will hold the settings in memory except Timer function. The unit will turn on at the same settings by pressing the power button again.	LCD illuminates and displays flame status Icon and temperature set point.	Fireplace emits single audible beep to confirm command to transition to ON or STANDBY state.
	FLAME	By pressing the FLAME button, the unit will cycle through four flame effects.	LCD illuminates and displays flame status icon.	Fireplace emits single audible beep to confirm command to transition between four FLAME states.
	HEATER	Press Heater button once, heater turns on LOW. Press Heater button twice, heater turns on HIGH. Press Heater button three times, heater turns off.	LCD illuminates and displays heater status icon.	Fireplace emits single audible beep to confirm command to transition between HEATER states. Fireplace displays one red LED for 10 seconds to confirm low heater command. Fireplace displays two red LED for ten (10) seconds to confirm high heater command.
	THERMOSTAT	Pressing the Temperature button adjusts the heaters response to the ambient temperature conditions in the room. Temperature adjusts from 16 °C - 28 °C (60 °F - 84 °F). Power button must be on to set °C to °F. Hold for 3 seconds and the LCD display from °C to °F.	Remote displays the temperature. If in Stand-by mode, temperature displays but cannot be adjusted.	Fireplace emits single audible beep to confirm command to change desired temperature set point.
	TIMER	Pressing the Timer button sets the time desired for the fireplace to run. The Timer can be set from .5 hour up to nine (9) hours in one (1) hour increments.	Remote will display the time setting selected. If in Stand-by mode time will display but cannot be adjusted.	
	LIGHT	Pressing the Light button changes the ember bed colors (14 color themes available - 13 colors and a color rotating option), and turns it on/off.	No indicator.	



C. Room Temperature and Thermostat Function

The temperature display on the remote control is a set point for the desired temperature of the room in which the appliance is installed. The Thermostat button on the remote can be used to set the desired room temperature. The heater will only operate if the remote control temperature set point is higher than the actual room temperature. The heater will not operate if the actual temperature is greater than the remote control temperature set point.

This function can also be used as a thermostat, under the following conditions:

- When the remote control display is set to a desired room temperature using the thermostat button, the appliance heater will turn OFF automatically when the room temperature reaches the set point.
- The heater will turn ON automatically if the room temperature falls below the set point.

Note: The actual room temperature is measured by a hidden sensor located behind the glass front of the appliance. During certain situations, this sensor temperature can be slightly different than either the remote control location, or the overall space being heated. For this reason, the remote control set point temperature may need to be set slightly higher or lower than expected room temperature for the heater function to work as desired.

D. Resetting Temperature Cutoff Switch

The heater is protected with a safety device to prevent overheating. Should the heater overheat, an automatic cutoff will turn the heater OFF. It will not turn ON automatically without being reset. If it overheats for any reason, it can be reset by:

1. Turn appliance to OFF.
2. Shut-off power at the circuit breaker.
3. Let appliance cool for 15 minutes.
4. Turn on power at the circuit breaker.
5. Turn on appliance with manual switch or remote control.

CAUTION: *If you need to continuously reset the heater, contact your dealer for service.*

6 MAINTENANCE

A. Maintenance

WARNING! Risk of Shock! Always remove power before moving or servicing. Do not immerse appliance in water.

- Before cleaning or servicing, always turn off appliance and remove power, by either unplugging from the wall outlet or shutting off circuit breaker.
- Light accumulated dust may be removed from the appliance exterior with a soft cloth or vacuum cleaner.
- Wipe the exterior surfaces of the appliance occasionally with a slightly damp micro fiber cloth using a solution of mild detergent and water. Dry thoroughly before operating the appliance.

CAUTION! Do not allow water to run into the interior of the appliance as this could create a fire or electric shock. Always remove power before moving or servicing.

- The fan motor is factory lubricated for life and will not require further lubrication.
- Store appliance in a clean dry place when not in use.

WARNING! Risk of Fire! To reduce risk of fire, do not store or use gasoline or any other flammable vapors or liquids in the vicinity of the appliance.

WARNING! Risk of Electrical Shock! Any other servicing needed must be performed by an authorized service representative. Do not attempt to service the unit yourself.

B. Cleaning

Cleaning Glass

Dust particles can be removed by buffing lightly with a clean dry cloth. Fingerprints and other marks can be cleaned with a cloth dampened with a quality household glass cleaner. The glass should be completely dried with a lint free cloth or paper towel. Do not use abrasive cleaners on glass surface. Do not spray liquids directly onto any surface.

Metal Surface

Dust particles can be removed by buffing lightly with a clean dry cloth. A damp cloth can be used to clean painted surfaces. Do not use abrasive cleaners. Do not spray liquids directly on to any surface.

C. Servicing

Except for cleaning, an authorized service representative should perform any other service.

D. SimpliFire Troubleshooting Guide

Symptom	Possible Cause	Corrective Action
Circuit breaker trips or fuse blows when unit is turned on	Exceeding current rating of the circuit breaker or fuse, perhaps from operating other appliances on the same circuit as the fireplace	Install unit onto a dedicated 15 amp circuit.
Lights in room dim while the unit is on	Unit is drawing close to circuit current rating	Install unit onto a dedicated 15 amp circuit.
Fireplace will not come on when using the manual controls on the unit	Appliance is not plugged into an electrical outlet	Ensure plug is connected to a working outlet.
	Hard-wire connections not correct (if applicable)	Review wiring instructions to ensure correct connection.
	No incoming power from the electrical outlet or electrical box	Check fuse/breaker panel.
	Defect in control board (PCB)	Replace the control board (PCB).
Remote control does not work	Low/dead batteries	Replace batteries in the remote.
	Remote receiver is blocked, or remote is not pointed directly at the receiver.	Ensure receiver is not blocked. Move closer to the appliance.
	Appliance power switch is in the off "O" position (if equipped)	Turn the power switch on, to the "I" position (if equipped).
	Control board (PCB) malfunction	Replace control board (PCB).
Heater will not turn on, but flame is functioning	Remote is in thermostat mode and room temperature (temperature at appliance thermistor) is higher than the set point on the remote	Increase thermostat set point on the remote, or exit thermostat mode (press the thermostat button until no temperature set point is displayed on the remote). See "Room Temperature and Thermostat Function" section of the manual.
	Appliance has overheated and safety thermal switch has tripped	Unplug or turn off power at circuit breaker and allow it to cool for 15 minutes. Then plug in the unit or turn power back on at circuit breaker and turn unit back on.
	Defective main control board	Replace control board (PCB).
	Defective heater assembly	Replace heater assembly.
Heater shuts off automatically or won't stay on	Room temperature (temperature at the appliance thermistor) is higher than the set point on the remote	Increase thermostat set point on the remote, or exit thermostat mode (toggle the thermostat button until no temperature set point is displayed on the remote). See "Room Temperature and Thermostat Function" section of the manual.
	Appliance has overheated and safety thermal switch has tripped	Unplug or turn off power at circuit breaker and allow it to cool for 15 minutes. Then plug in the unit or turn power back on at circuit breaker and turn unit back on.
Heater emits an odor	Normal operation	It is normal for the heater to emit an odor for a brief amount of time after turning on. It is burning off dust that has accumulated on the heater.
Flame does not move at all	Flame rotisserie motor is stalled or malfunctioning	Cycle unit on or off. If problem persists inspect rotisserie and motor for blockage or interference. If no interference, replace the control board (PCB) and rotisserie motor.
Flame shudder	Flame rotisserie contacting other internal components when spinning	Ensure rod is straight and mounted properly and is spinning freely without spindles hitting other components.
	Defective flame rotisserie motor	Replace rotisserie motor.
Ember bed does not light up	Ember bed is turned off	Refer to operation section of the user manual.
	Loose wiring	Check wiring to ember bed LEDs.
	Defective control board (PCB)	Replace control board (PCB).
	Defective LED lights	Replace ember bed LED lights.

SimpliFire Troubleshooting Guide (continued)

Symptom	Possible Cause	Corrective Action
Fireplace turns on by itself	Defective control board (PCB)	Replace control board (PCB).
	Similar infrared signal from another remote causing unit to turn on (pre-2019 manufactured units only)	Some TV remotes may cause the fireplace to turn on for appliances manufactured before 2019. Replace control board (PCB).
Excessive noise with heater on	Interference with fan blade	Inspect heater assembly and fan for obstructions or interference.
	Defective blower motor	Replace heater assembly.
Grinding or rubbing noise (when heater is off)	Rotisserie hitting or rubbing against internal components	Ensure rotisserie rod is straight and mounted properly and is spinning freely without spindles hitting other components. If sound is coming from friction with the rotisserie bracket, apply grease to contact point.

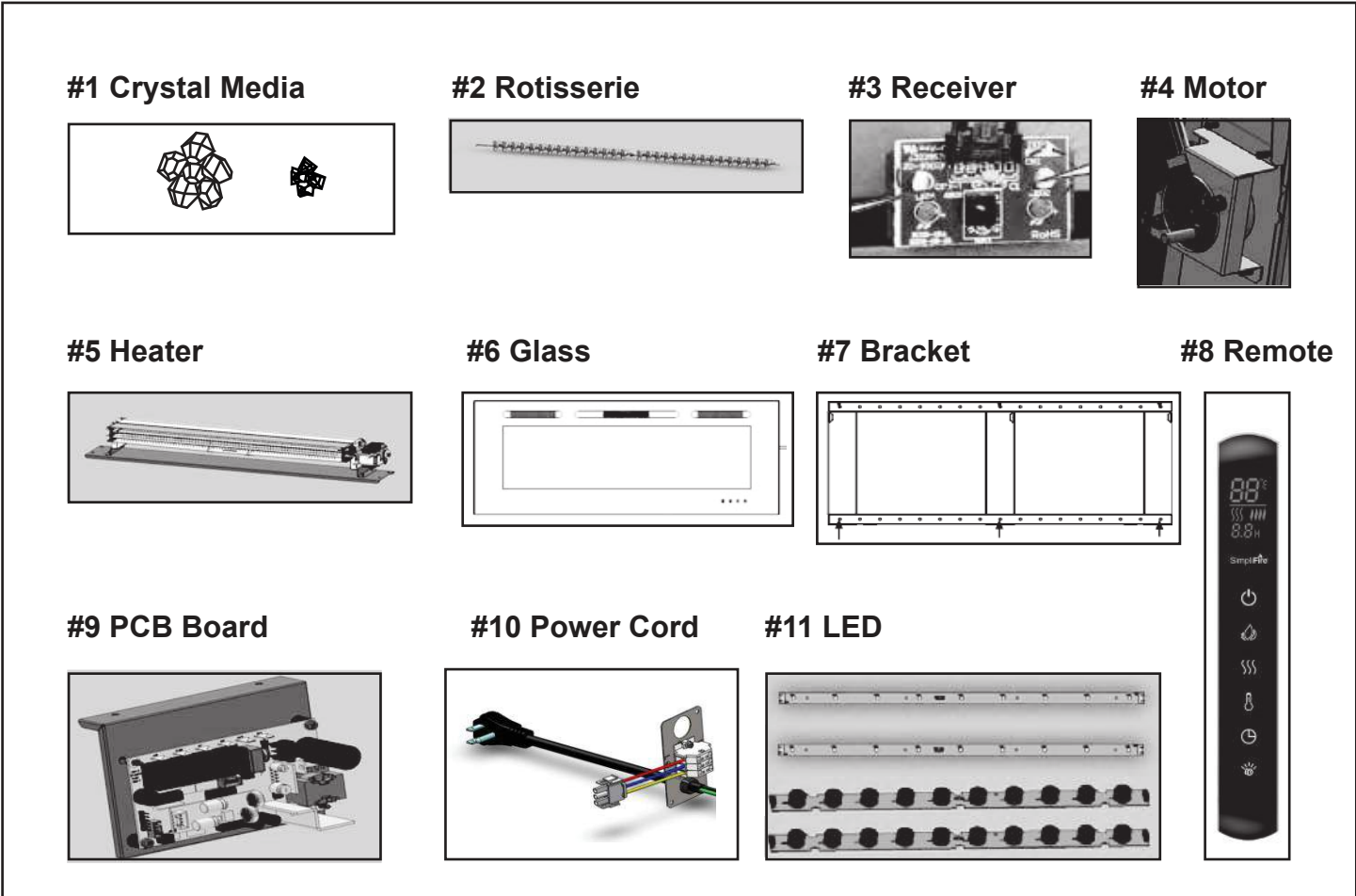

IMPORTANT: THIS IS DATED INFORMATION. Parts must be ordered from a dealer or distributor. **Hearth and Home Technologies does not sell directly to consumers.** Provide model number and serial number when requesting service parts from your dealer or distributor.



Stocked at Depot

ITEM	DESCRIPTION	COMMENTS	PART NUMBER	
1	Crystal Media		CRYSTAL-ALLUS	
2	Rotisserie, 40"		ROTISS-ALL40	Y
3	Remote Receiver		RECEIV-ALLUS-E	Y
4	Allusion Motor		MOTOR-ALLUS	Y
5	Heater Assembly		HEATER-ALLUS	Y
6	Glass Front, 40"		GLA-ALL40	
7	Hanging Bracket		BRACKET-ALL48	
8	Remote		REMOT-ELECT-ALL	Y
9	PCB Board Assembly		PCB-ALLUS	Y
10	Power Cord		PLUGIN-ALLP	Y
11	LED Assembly, 40"	Emberbed & Flame	LED-ALL40	Y
	Allusion Hardware Kit	Fixing Brackets & Screws	HDWR-ALLUS	

#1 Crystal Media

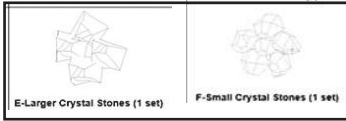

#2 Rotisserie



#3 Receiver



#4 Motor

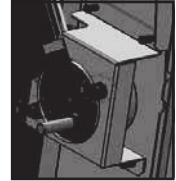

#5 Heater

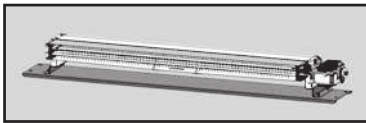

#6 Glass

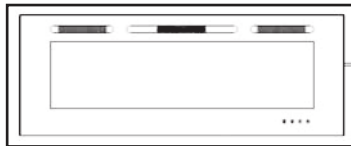

#7 Bracket

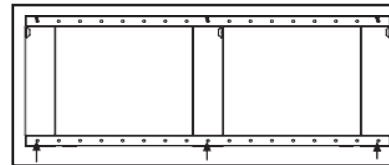

#8 Remote



#9 PCB Board

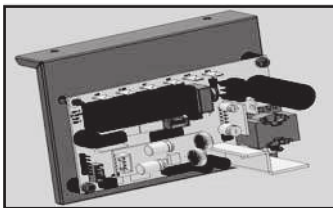

#10 Power Cord

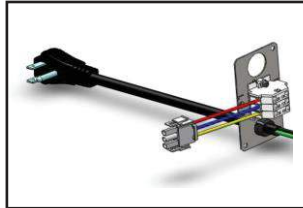

#11 LED

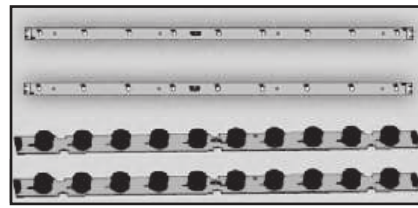

IMPORTANT: THIS IS DATED INFORMATION. Parts must be ordered from a dealer or distributor. **Hearth and Home Technologies does not sell directly to consumers.** Provide model number and serial number when requesting service parts from your dealer or distributor.



Stocked at Depot

ITEM	DESCRIPTION	COMMENTS	PART NUMBER	
1	Crystal Media		CRYSTAL-ALLUS	
2	Rotisserie, 48"		ROTISS-ALL48	Y
3	Remote Receiver		RECEIV-ALLUS-E	Y
4	Allusion Motor		MOTOR-ALLUS	Y
5	Heater Assembly		HEATER-ALLUS	Y
6	Glass Front, 48"		GLA-ALL48	
7	Hanging Bracket		BRACKET-ALL48	
8	Remote		REMOT-ELECT-ALL	Y
9	PCB Board Assembly		PCB-ALLUS	Y
10	Power Cord		PLUGIN-ALLP	Y
11	LED Assembly, 48"		LED-ALL48	Y
	Allusion Hardware Kit	Fixing Brackets & Screws	HDWR-ALLUS	

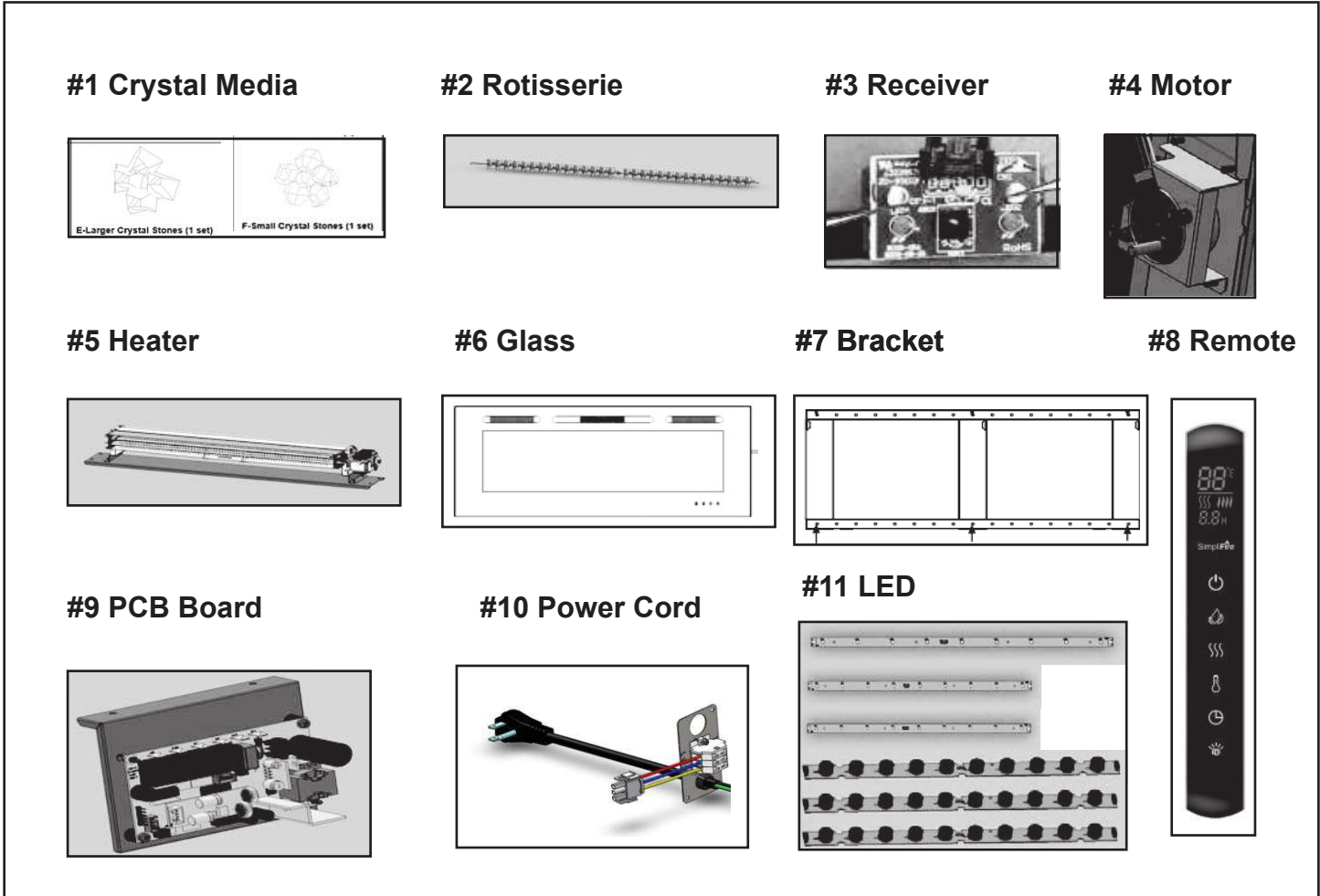

IMPORTANT: THIS IS DATED INFORMATION. Parts must be ordered from a dealer or distributor. **Hearth and Home Technologies does not sell directly to consumers.** Provide model number and serial number when requesting service parts from your dealer or distributor.



Stocked at Depot

ITEM	DESCRIPTION	COMMENTS	PART NUMBER	
1	Crystal Media		CRYSTAL-ALLUS	
2	Rotisserie, 60"		ROTISS-ALL60	Y
3	Remote Receiver		RECEIV-ALLUS-E	Y
4	Allusion Motor		MOTOR-ALLUS	Y
5	Heater Assembly		HEATER-ALLUS	Y
6	Glass Front, 60"		GLA-ALL60	
7	Hanging Bracket		BRACKET-ALL60	
8	Remote		REMOT-ELECT-ALL	Y
9	PCB Board Assembly		PCB-ALLUS	Y
10	Power Cord		PLUGIN-ALLP	Y
11	LED Assembly, 60"		LED-ALL60	Y
	Allusion Hardware Kit	Fixing Brackets & Screws	HDWR-ALLUS	

#1 Crystal Media



#2 Rotisserie



#3 Receiver

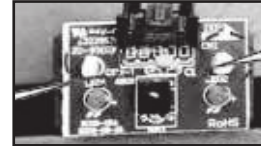

#4 Motor

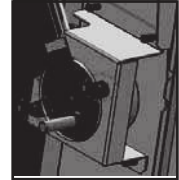

#5 Heater

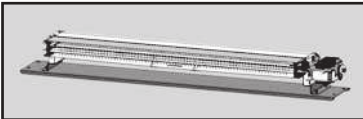

#6 Glass

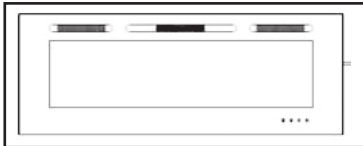

#7 Bracket

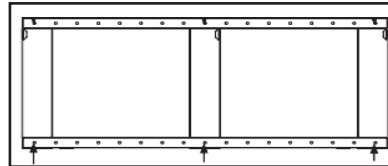

#8 Remote



#9 PCB Board

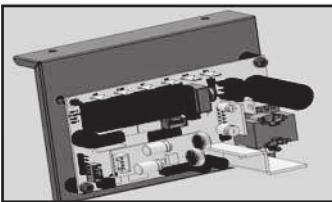

#10 Power Cord

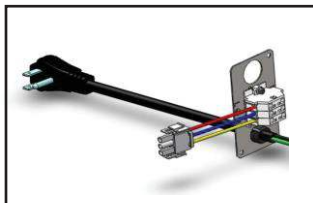

#11 LED Assembly

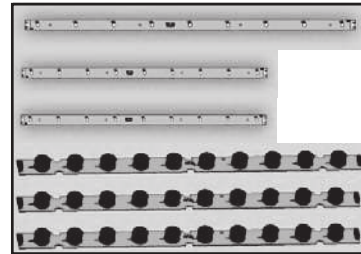

IMPORTANT: THIS IS DATED INFORMATION. Parts must be ordered from a dealer or distributor. **Hearth and Home Technologies does not sell directly to consumers.** Provide model number and serial number when requesting service parts from your dealer or distributor.



Stocked at Depot

ITEM	DESCRIPTION	COMMENTS	PART NUMBER	
1	Crystal Media		CRYSTAL-ALLUS	
2	Rotisserie, 84"		ROTISS-ALL84	Y
3	Remote Receiver		RECEIV-ALLUS-E	Y
4	Allusion Motor		MOTOR-ALLUS	Y
5	Heater Assembly		HEATER-ALLUS	Y
6	Glass Front, 84"		GLA-ALL84	
7	Hanging Bracket		BRACKET-ALL84	
8	Remote		REMOT-ELECT-ALL	Y
9	PCB Board Assembly		PCB-ALLUS	Y
10	Power Cord		PLUGIN-ALLP	Y
11	LED Assembly, 84"	Emberbed & Flame	LED-ALL84	Y
	Allusion Hardware Kit	Fixing Brackets & Screws	HDWR-ALLUS	

